



EBARA



	Page
- SPECIFICATIONS	200
SELECTION CHART	201
TYPE KEY AND CURVE SPECIFICATIONS	202
PERFORMANCE CURVE CDX 70	203
PERFORMANCE CURVE CDX 120	204
PERFORMANCE CURVE CDX 200	205
- CONSTRUCTIONS	300
SECTIONAL VIEW	300
MECHANICAL SEAL	301
- DIMENSIONS AND WEIGHT	400
PUMP	400
PACKING	401
- TECHNICAL DATA	500
MOTOR DATA	500
NOISE DATA	500

SPECIFICATION

50Hz

Rev. H

PUMP		
Liquid Handled	Type of liquid	Clean water
	Temperature [°C]	min. -5 max. 60 (CDX 70/05-70/07-90/10) max. 90 max. 110 (H-HS-HW-HSW)
Maximum working pressure	[MPa]	0.8
Construction	Impeller	Closed centrifugal type
	Shaft seal type	Mechanical seal
	Bearing	Sealed ball bearing
Pipe Connection	Suction	G 1¼ (G 1½ CDX200)
	Discharge	G 1
Material	Casing	AISI 304
	Impeller	AISI 304
	Casing cover	AISI 304
	Shaft seal	Ceramic/Carbon/NBR (for CDX) Ceramic/Carbon/FPM (for CDXH) SiC/SiC/FPM (for CDXHS) Tungsten Carbide/Tungsten Carbide/FPM (for CDXHW) SiC/Tungsten Carbide/FPM (for CDXHSW)
	Shaft	AISI 303 (Wet extension)
	Bracket	Aluminium
Applicable standard of test		ISO 9906 – Annex A

MOTOR		
Type	Electric - TEFC	
	Single Phase	Three Phase
Efficiency level (Reg. 640/2009)	-	- from 0.37 kW up to 0.55 kW IE2 from 0.75 kW up to 1.8 kW
No. of Poles	2	
Rotation speed [min ⁻¹]	≈ 2800	
Insulation Class	F	
Protection degree (CEI EN 60034-5)	IP 55	
Power rating	[kW]	0.37 ÷ 1.5
	[HP]	0.5 ÷ 2
Frequency [Hz]	50	
Voltage [V]	230 ±10%	230/400 ±10%
Capacitor	Built in	-
Over load protection	Built in	Provided by the user
Casing material	Aluminium	
Base material/motor support	Aluminium	
Dimensions of cable entry	PG11 - PG13.5 (see dimensions page 400)	

SELECTION CHART

50Hz

Rev. H

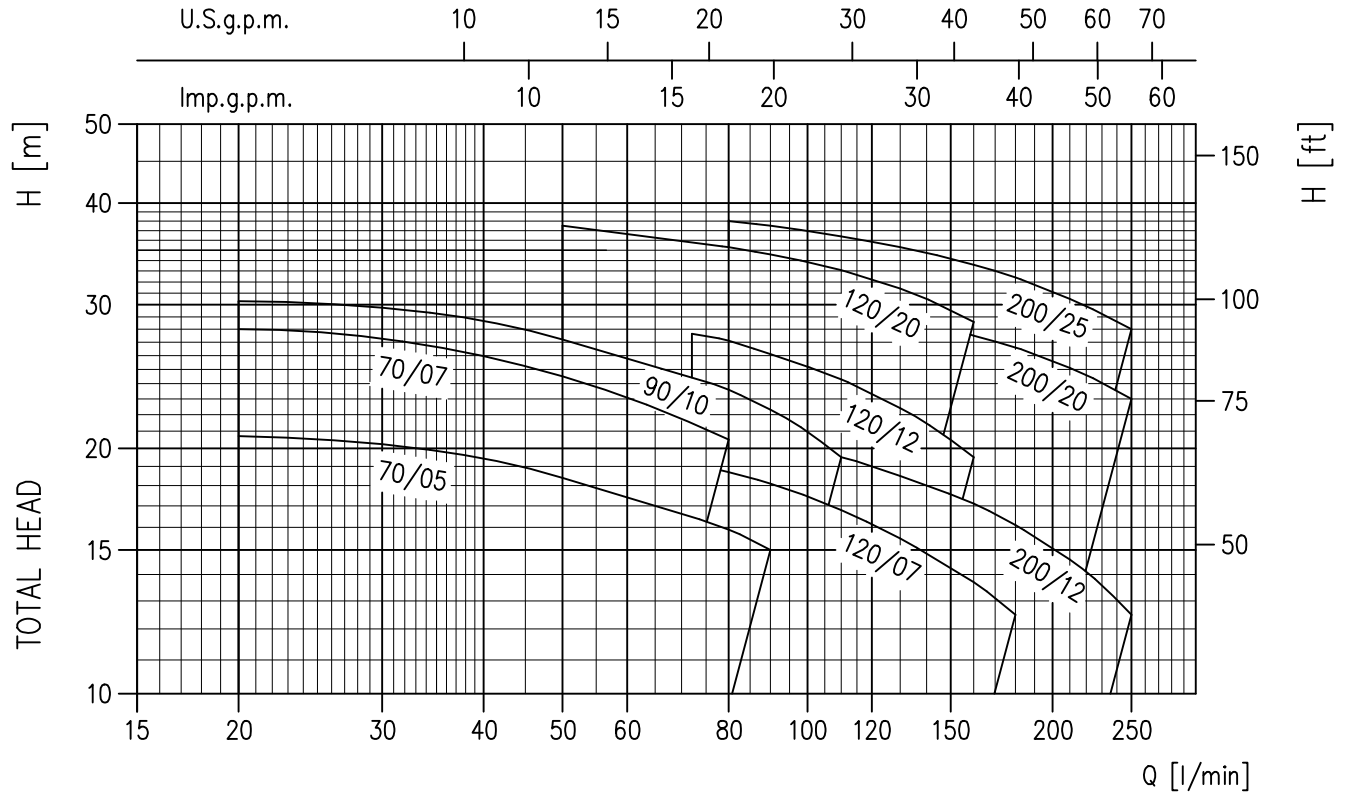

Pump type		Power		Q=Capacity											
				l/min	0	20	50	80	90	110	130	160	180	210	250
Single Phase	Three Phase	[kW]	[HP]	m ³ /h	0	1.2	3	4.8	5.4	6.6	7.8	9.6	10.8	12.6	15
				H=Total manometric head in meters											
CDXM 70/05	CDX 70/05	0.37	0.5	22	20.7	18.4	15.9	15	-	-	-	-	-	-	-
CDXM 70/07	CDX 70/07	0.55	0.8	30	28	24.5	20.5	-	-	-	-	-	-	-	-
CDXM 90/10	CDX 90/10	0.75	1	32	30.3	27.2	23.6	22.3	19.5	-	-	-	-	-	-
CDXM 120/07	CDX 120/07	0.55	0.8	22.5	-	20.5	18.7	18.1	16.8	15.5	13.7	12.5	-	-	-
CDXM 120/12	CDX 120/12	0.9	1.2	32	-	29.5	27.1	26.1	24.3	22.4	19.5	-	-	-	-
CDXM 120/20	CDX 120/20	1.5	2	40.5	-	37.5	35.3	34.6	33.1	31.4	28.6	-	-	-	-
CDXM 200/12	CDX 200/12	0.9	1.2	23	-	-	20.7	20.2	19.5	18.5	17.1	16.1	14.6	12.5	-
CDXM 200/20	CDX 200/20	1.5	2	34	-	-	31	30.6	29.7	28.9	27.5	26.6	25.1	23	-
-	CDX 200/25	1.8	2.5	41	-	-	38	37.5	36.4	35.3	33.6	32.4	30.5	28	-

TYPE KEY AND CURVE SPECIFICATIONS

50Hz

Rev. H

TYPE KEY

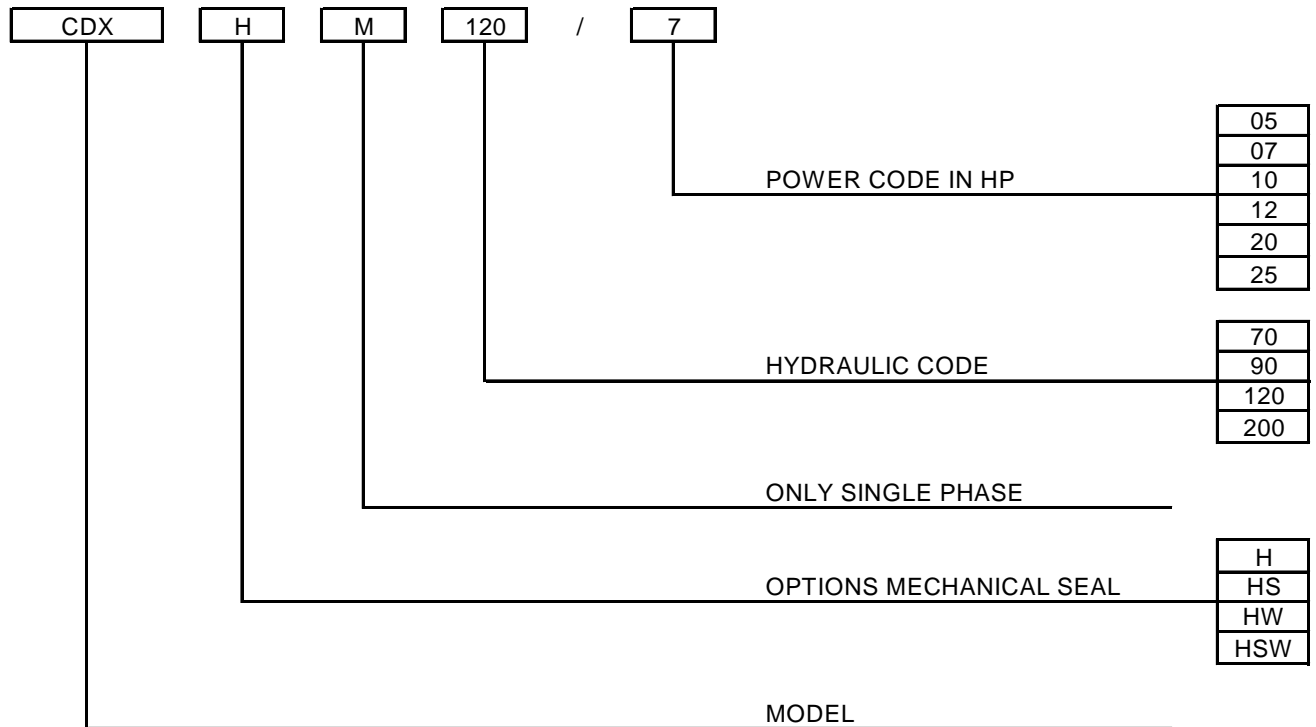

PERFORMANCE CURVE SPECIFICATIONS

The specifications below qualify the curves shown on the following pages.

Tolerances according to ISO 9906 Annex A

The curves refer to effective speed of asynchronous motors at 50 Hz

Measurements were carried out with clean water at 20°C of temperature and with a kinematic viscosity of $\nu = 1 \text{ mm}^2/\text{s}$ (1 cSt)

The NPSH curve is an average curve obtained in the same conditions of performance curves.

The continuous curves indicate the recommended working range. The dotted curve is only a guide.

In order to avoid the risk of over-heating, the pumps should not be used at a flow rate below 10% of best efficiency point.

Symbols explanation:

- Q = volume flow rate
- H = total head
- P_2 = pump power input (shaft power)
- η = pump efficiency
- NPSH = net positive suction head required by the pump

CDX 70/05 (0.37 kW) - Impeller diameter = 132 mm
 CDX 70/07 (0.55 kW) - Impeller diameter = 157 mm

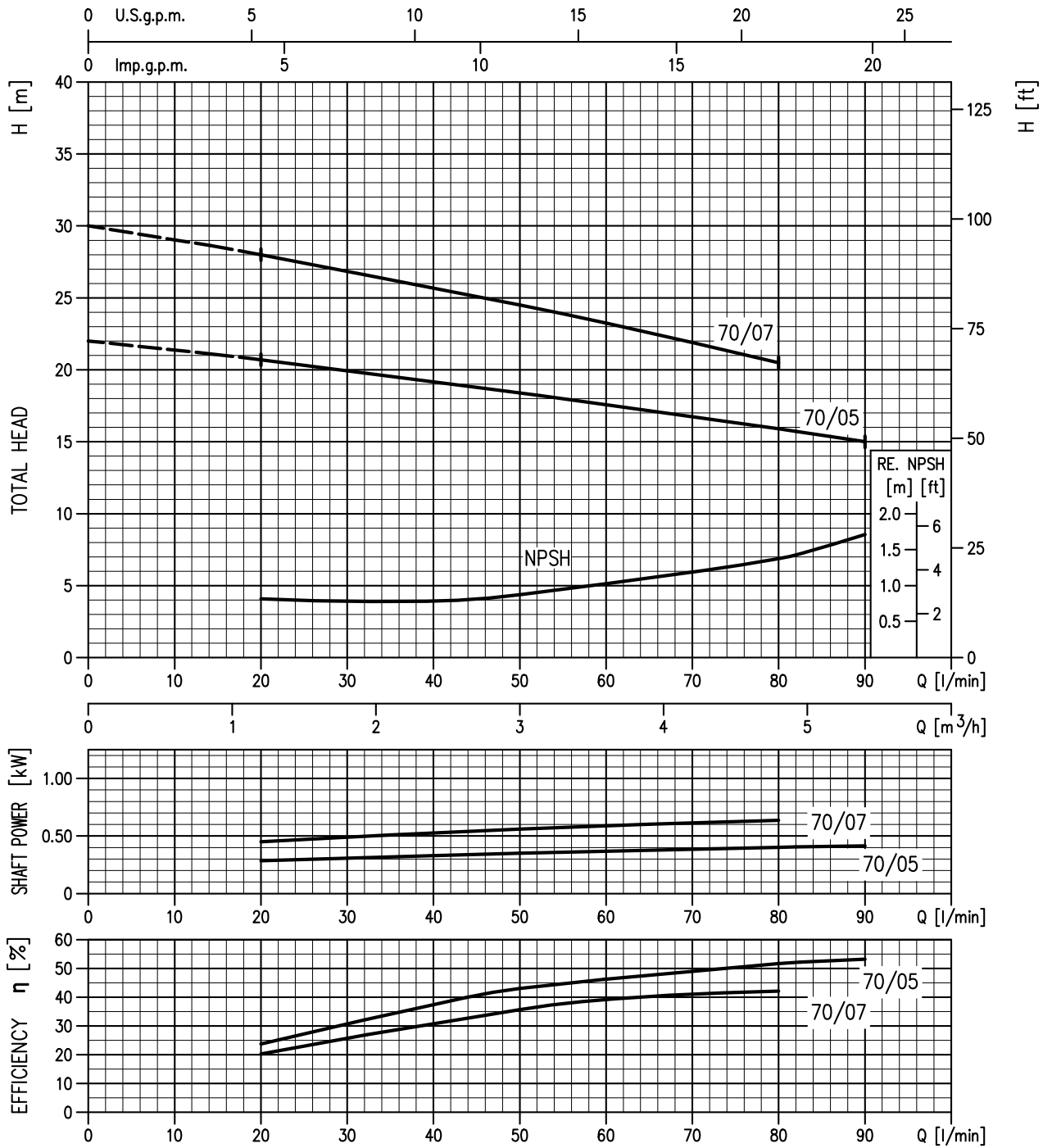

Rotation speed $\approx 2800 \text{ min}^{-1}$
 Test standard: ISO 9906 – Annex A

CDX 90/10 (0.75 kW) - Impeller diameter = 157 mm

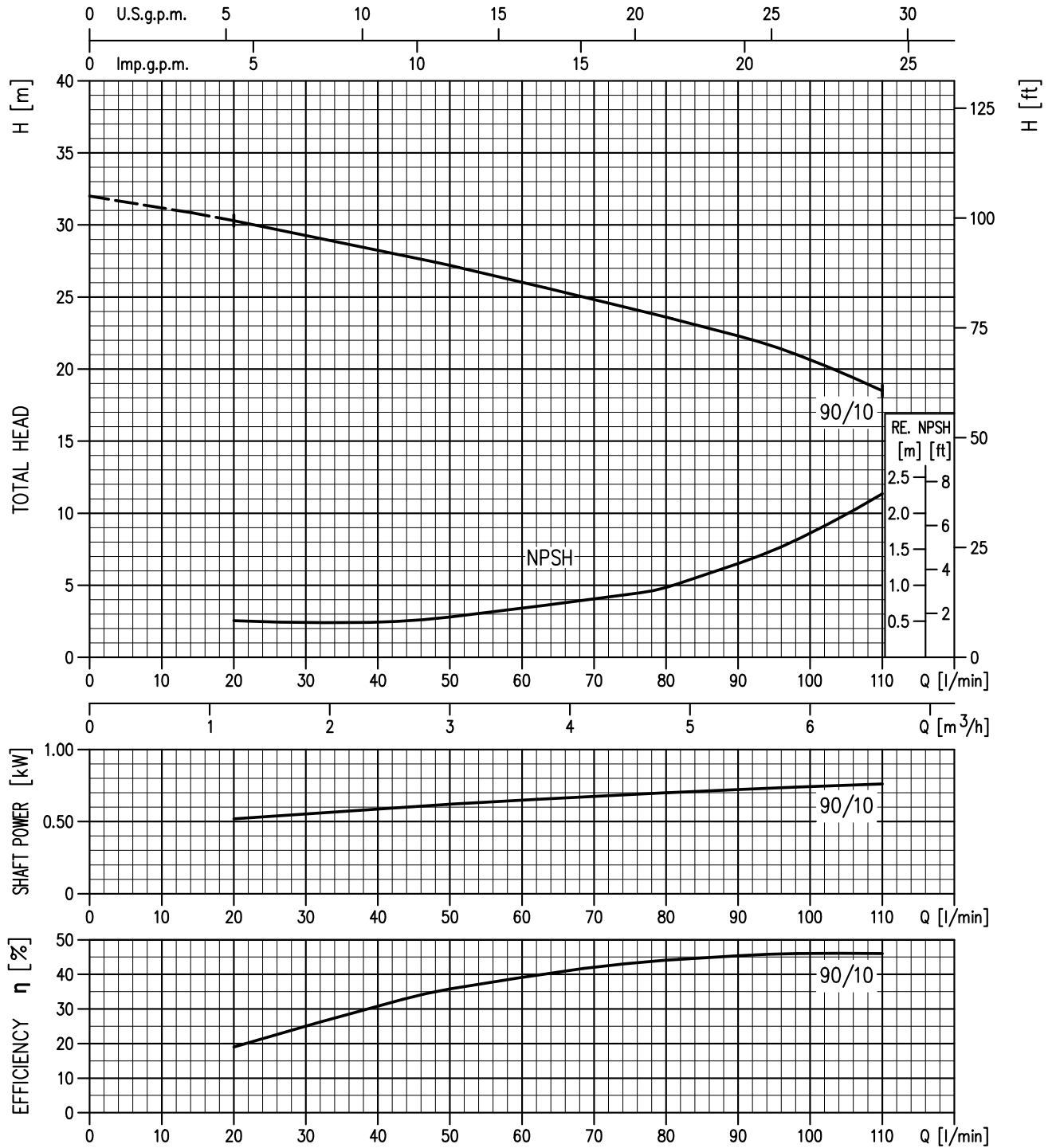

Rotation speed $\approx 2800 \text{ min}^{-1}$
 Test standard: ISO 9906 – Annex A

CDX 120/07 (0.55 kW) - Impeller diameter = 132 mm
 CDX 120/12 (0.90 kW) - Impeller diameter = 157 mm
 CDX 120/20 (1.50 kW) - Impeller diameter = 176 mm

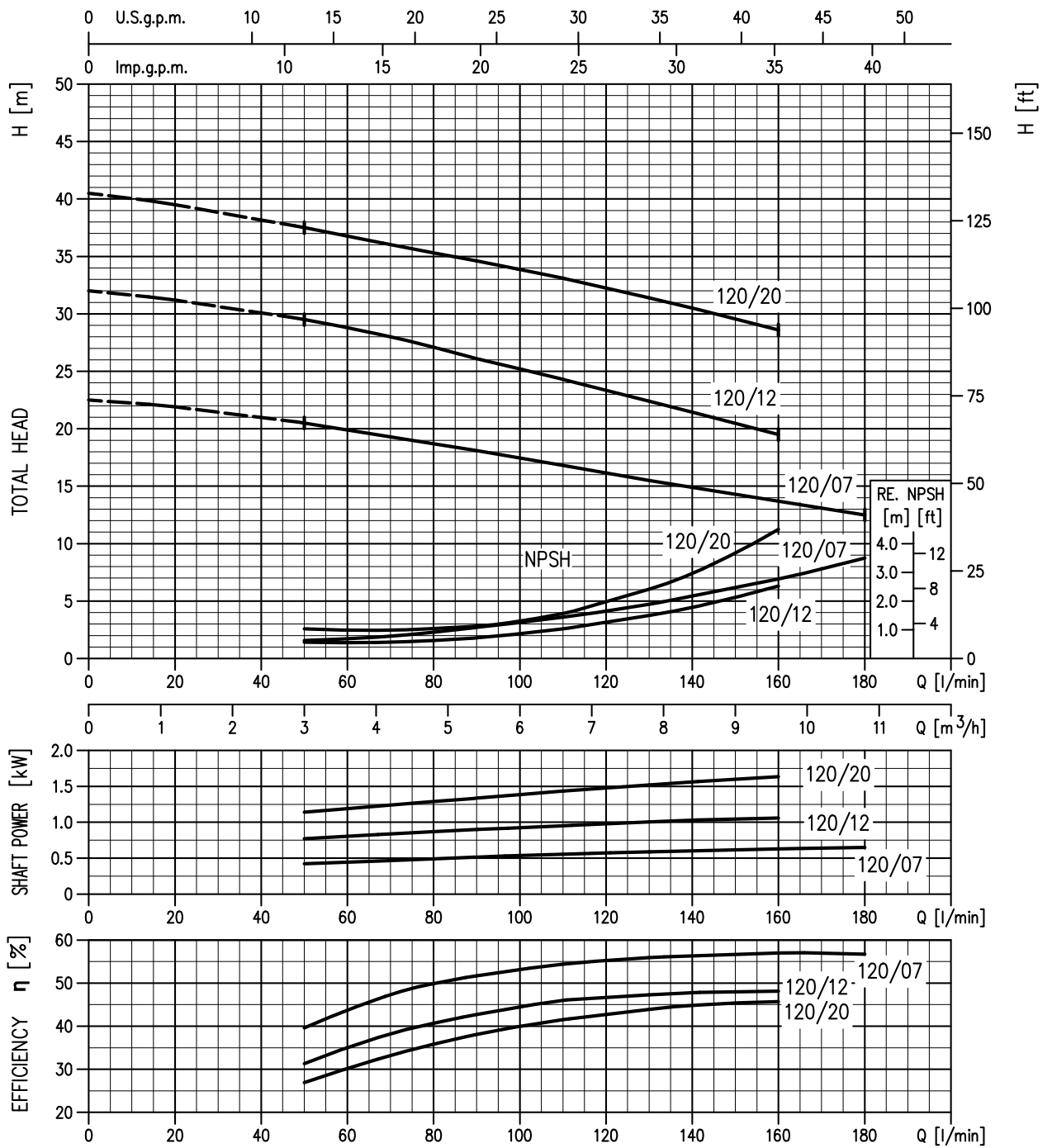

Rotation speed $\approx 2800 \text{ min}^{-1}$
 Test standard: ISO 9906 – Annex A

CDX 200/12 (0.9 kW) - Impeller diameter = 132 mm
 CDX 200/20 (1.5 kW) - Impeller diameter = 157 mm
 CDX 200/25 (1.8 kW) - Impeller diameter = 176 mm

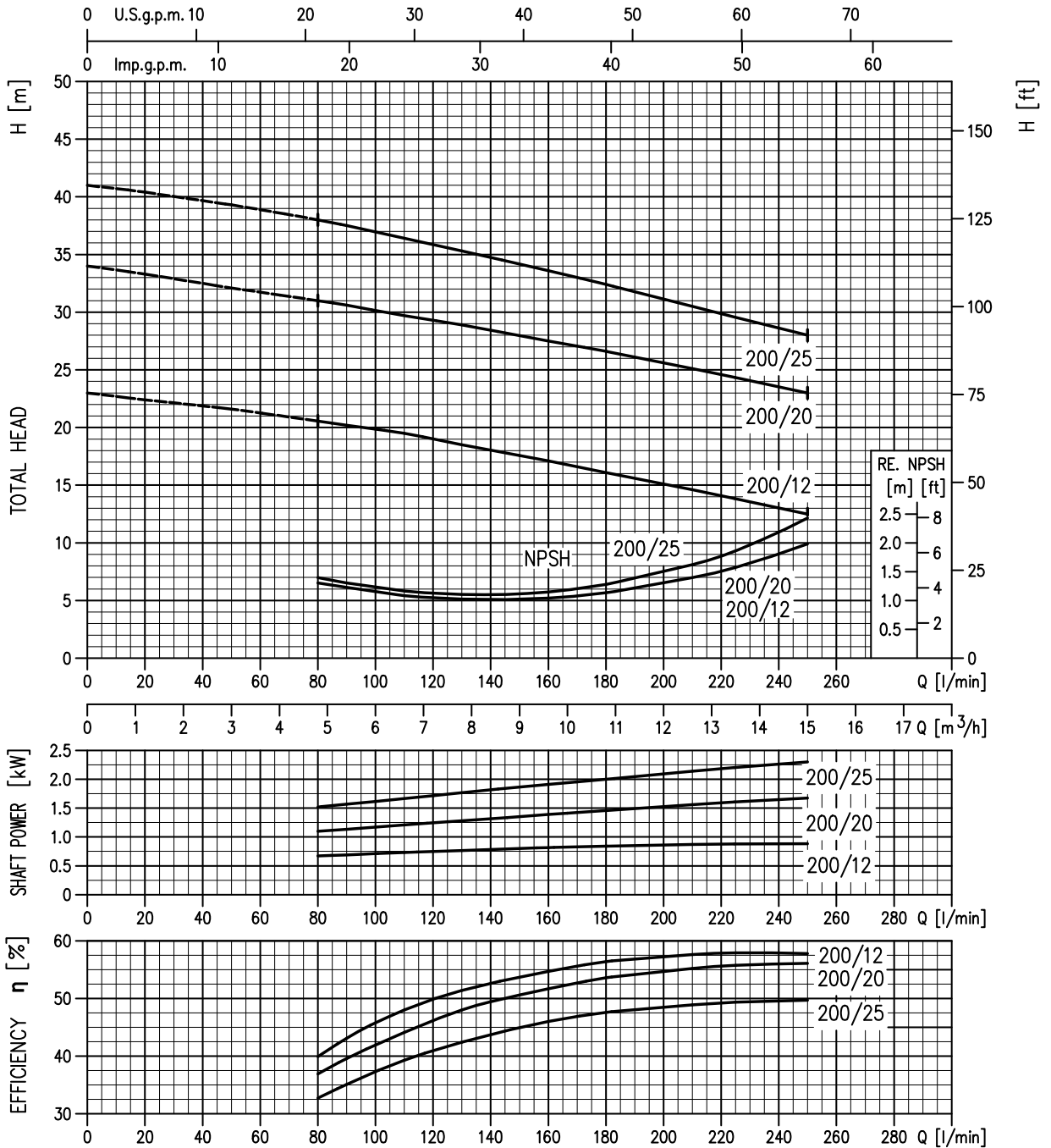

Rotation speed $\approx 2800 \text{ min}^{-1}$
 Test standard: ISO 9906 – Annex A

SECTIONAL VIEW

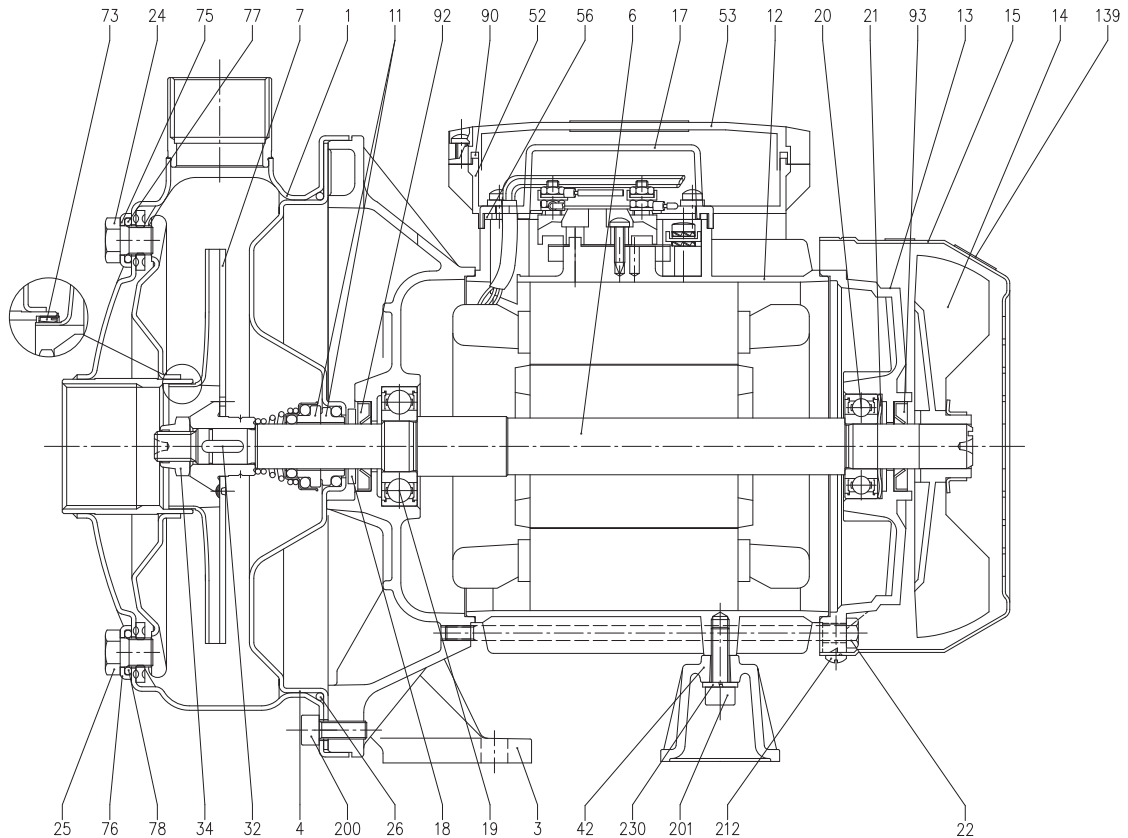

N°	PART NAME	MATERIAL	Q.TY	N°	PART NAME	MATERIAL	Q.TY
1	Casing	AISI 304	1	25	Drain plug	AISI 303	1
3	Motor bracket	Aluminium	1	26	O-ring [3]	NBR	1
4	Casing cover	AISI 304	1	32	Key	AISI 316	1
6	Shaft with rotor	AISI 303 (Wet extension)	1	34	Impeller nut	AISI 304	1
7	Impeller	AISI 304	1	42	Motor support	Aluminium	1
11	Mechanical seal [3]	Carbon/Ceramic/NBR	1	52	Terminal box [1]	ABS	1
12	Motor frame with stator	-	1	53	Terminal box cover [1] [5]	ABS [5]	1
13	Motor cover	Aluminium	1	56	Box gasket	NBR	1
14	Fan	PA	1	73	Casing ring [4]	AISI 304	1
15	Fan cover	Fe P04 Zincate	1	75	Washer	AISI 304	1
16	Terminal board	-	1	76	Washer	AISI 304	1
17	Terminal box cover [2]	Aluminium	1	77	O-ring [3]	NBR	1
18	Splash ring	NBR	1	78	O-ring [3]	NBR	1
19	Pump side ball bearing	-	1	90	Terminal box cover gasket [1]	NBR	1
20	Fan side ball bearing	-	1	92	Lip seal	-	1
21	Adjusting ring	Steel C70	1	93	Lip seal	-	1
22	Tie rod	Fe 420 Zincate	4	110	Protector [1]	-	1
23	Capacitor [1]	-	1	200	Screw	Stainless steel A2 UNI7323	8
24	Priming plug	AISI 303	1				

[1] Only for single phase

[2] Only for three phase

[3] FPM for CDX H-HS-HW-HSW

[4] NBR for CDX 70/05, 70/07, 90/10

FPM for CDX H-HS-HW-HSW 70/05, 70/07, 90/10

[5] Whit gasket in NBR only for version single phase CDX 70/05, 70/07, 90/10, 120/07

MECHANICAL SEAL

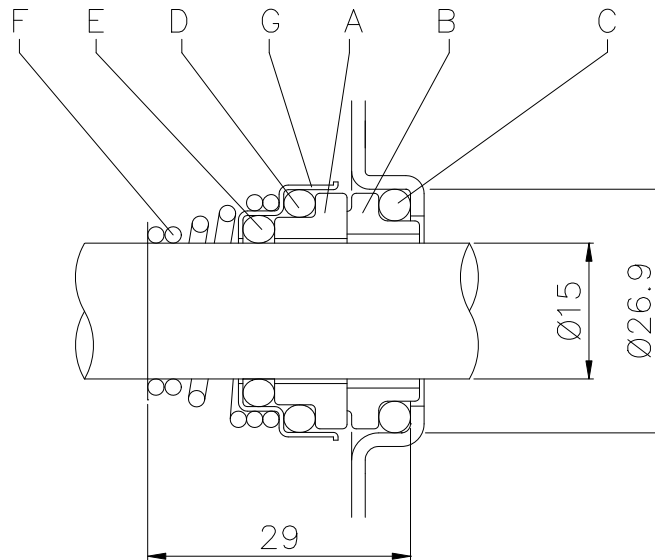

REF	PART NAME	Standard version (CDX)	MATERIAL			
			(CDXH)	(CDXHS)	Optional (CDXHW) (CDXHWS)	
A	Rotary seal ring	Ceramic	Ceramic	Silicon carbide	Tungsten carbide	Silicon carbide
B	Stationary seal ring	Carbon graphite	Carbon graphite	Silicon carbide	Tungsten carbide	Tungsten carbide
C	O Ring	NBR	FPM	FPM	FPM	FPM
D	O Ring	NBR	FPM	FPM	FPM	FPM
E	O Ring	NBR	FPM	FPM	FPM	FPM
F	Self driving spring	AISI 316	AISI 316	AISI 316	AISI 316	AISI 316
G	Frame	AISI 304	AISI 304	AISI 316	AISI 316	AISI 316

BEARINGS

Pump type		Ball Bearing	
Single Phase	Three Phase	Pump side	Fan side
CDXM 70/05	CDX 70/05	6203 2RSH	6202 2RSH
CDXM 70/07	CDX 70/07	6203 2RSH	6202 2RSH
CDXM 90/10	CDX 90/10	6203 2RSH	6202 2RSH
CDXM 120/07	CDX 120/07	6203 2RSH	6202 2RSH
CDXM 120/12	CDX 120/12	6203 2RSH	6202 2RSH
CDXM 120/20	CDX 120/20	6204 2RSH	6203 2RSH
CDXM 200/12	CDX 200/12	6203 2RSH	6202 2RSH
CDXM 200/20	CDX 200/20	6204 2RSH	6203 2RSH
-	CDX 200/25	6204 2RSH	6203 2RSH

PUMP

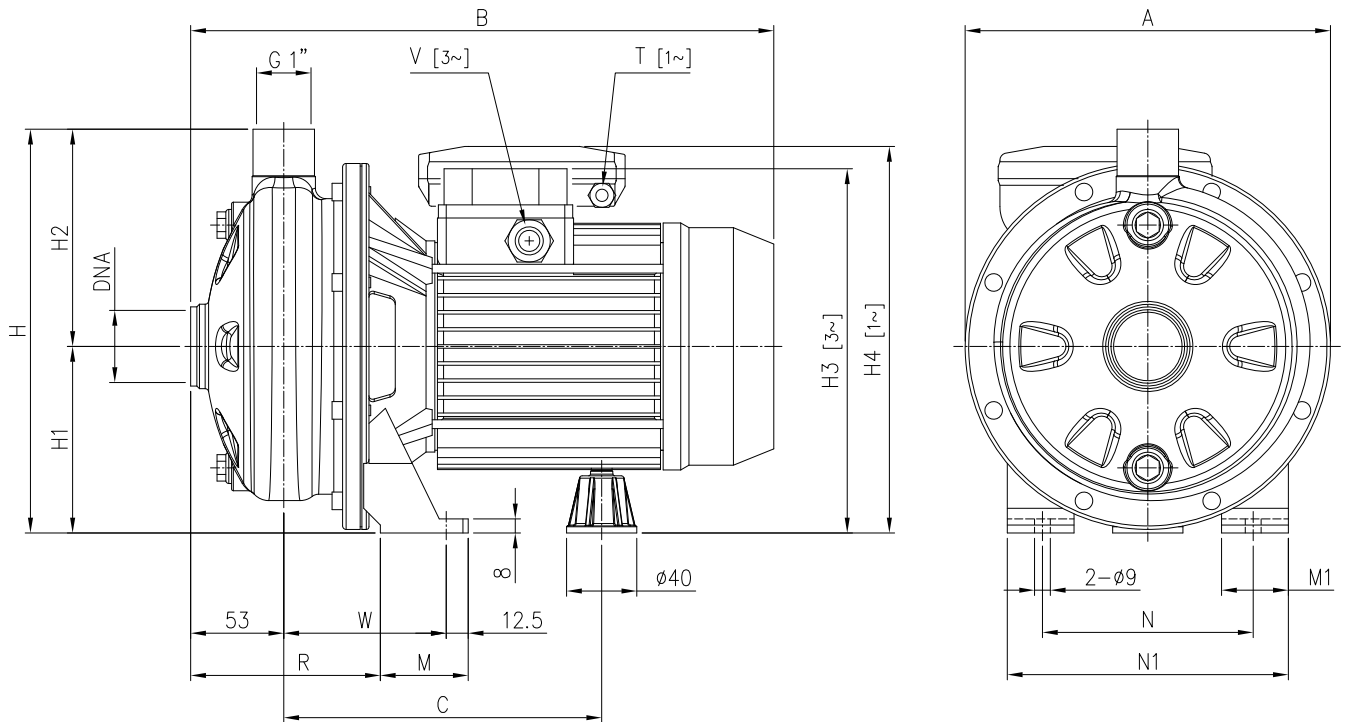

Pump type CDXM CDX	Dimensions [mm]																	Weight [kgf]			
	A	B		C	H	H1	H2	H3	H4	M	M1	N	N1	R	T	V	W	DNA	[1~]	[3~]	
		[1~]	[3~]					[3~]	[1~]						[1~]	[3~]					
70/05	208	321	320	181	229.5	106	123.5	207	216	50	38	120	160	108	PG11	PG11	92.5	G1 1/4	8.3	8.3	
70/07	208	321	320	181	229.5	106	123.5	207	216	50	38	120	160	108	PG11	PG11	92.5	G1 1/4	9.8	9.7	
90/10	208	321	320	181	229.5	106	123.5	207	216	50	38	120	160	108	PG11	PG11	92.5	G1 1/4	11	11	
120/07	208	321	320	181	229.5	106	123.5	207	216	50	38	120	160	108	PG11	PG11	92.5	G1 1/4	9.6	9.5	
120/12	208	321	332	181	229.5	106	123.5	207	235	50	38	120	160	108	PG11	PG11	92.5	G1 1/4	11.8	12.4	
120/20	232	346.5	359	198.5	250	118	132	237	248.5	55	40	140	180	105.5	PG13.5	PG11	95	G1 1/4	16.5	17.2	
200/12	208	321	332	181	229.5	106	123.5	207	235	50	38	120	160	108	PG13.5	PG11	92.5	G1 1/2	11.4	12.2	
200/20	208	346.5	359	198.5	229.5	106	123.5	225	236.5	55	40	140	180	105.5	PG13.5	PG11	95	G1 1/2	15.3	16.1	
200/25	232	-	359	198.5	250	118	132	237	-	55	40	140	180	105.5	-	PG11	95	G1 1/2	-	15.9	

[1~] Single phase

[3~] Three phase

PACKING

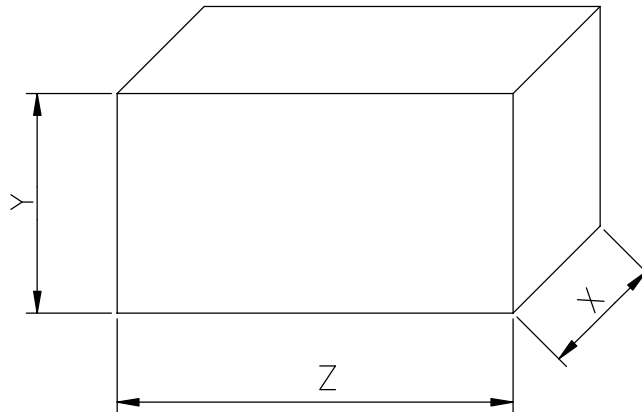

Pump Type		Packing [mm]						Weight [kg]	
Single Phase	Three Phase	X		Y		Z		[1~]	[3~]
		[1~]	[3~]	[1~]	[3~]	[1~]	[3~]		
CDXM 70/05	CDX 70/05	227	227	280	280	335	335	9	9
CDXM 70/07	CDX 70/07	227	227	280	280	335	335	10.4	10.4
CDXM 90/10	CDX 90/10	227	227	280	280	335	335	11.7	11.6
CDXM 120/07	CDX 120/07	227	227	280	280	335	335	10.2	10.4
CDXM 120/12	CDX 120/12	227	239	280	289	335	372	12.5	13.2
CDXM 120/20	CDX 120/20	245	239	315	289	360	372	17.2	18
CDXM 200/12	CDX 200/12	218	239	280	289	332	372	12.1	12.9
CDXM 200/20	CDX 200/20	250	239	315	289	375	372	16	16.8
-	CDX 200/25	-	245	-	305	-	380	-	16.7

[1~] Single phase
 [3~] Three phase

MOTOR DATA

Pump type		Power		Efficiency		Capacitor		Efficiency (% load)			Input		Full load current			Locked rotor current		
Single Phase	Three Phase	[kW]	[HP]	Single Phase	Three Phase	Single Phase	Three Phase	Three phase			Single Phase	Three Phase	[A]			[A]		
								[μF]	[V]	η %			50%	75%	100%	Phase	Phase	230 V
CDXM 70/05	CDX 70/05	0.37	0.5	-	-	12.5	450	-	-	-	0.75	0.68	3.4	2.4	1.4	10.1	11.0	6.15
CDXM 70/07	CDX 70/07	0.55	0.75	-	-	16	450	-	-	-	1.1	1.0	5.0	3.5	2.0	16.1	17.0	9.7
CDXM 90/10	CDX 90/10	0.75	1.0	-	IE2	20	450	77.2	80.9	81.3	1.2	1.60	5.6	3.3	1.9	22.7	22.0	12.9
CDXM 120/07	CDX 120/07	0.55	0.75	-	IE2	16	450	-	-	-	1.0	1.0	4.6	3.2	1.85	16.1	17.0	9.7
CDXM 120/12	CDX 120/12	0.9	1.2	-	IE2	31.5	450	79.0	81.7	81.6	1.6	1.45	6.9	4.5	2.6	25.0	31.0	17.8
CDXM 120/20	CDX 120/20	1.5	2.0	-	IE2	40	450	80.3	83.4	83.8	2.1	2.09	9.3	6.9	4.0	43.0	34.3	20.0
CDXM 200/12	CDX 200/12	0.9	1.2	-	IE2	31.5	450	79.0	81.7	81.6	1.4	1.35	6.3	4.3	2.5	25.0	31.0	17.8
CDXM 200/20	CDX 200/20	1.5	2.0	-	IE2	40	450	80.3	83.4	83.8	2.3	2.22	10.2	7.4	4.3	43.0	34.3	20.0
-	CDX 200/25	1.8	2.5	-	IE2	-	-	83.0	84.4	83.8	-	2.87	-	8.7	5.0	-	59.0	34.3

NOISE DATA

Pump type		Power		L _{pA} - dB(A) *
Single Phase	Three Phase	[kW]	[HP]	
CDXM 70/05	CDX 70/05	0.37	0.5	<70
CDXM 70/07	CDX 70/07	0.55	0.75	
CDXM 90/10	CDX 90/10	0.75	1.0	
CDXM 120/07	CDX 120/07	0.55	0.75	
CDXM 120/12	CDX 120/12	0.9	1.2	
CDXM 120/20	CDX 120/20	1.5	2.0	
CDXM 200/12	CDX 200/12	0.9	1.2	
CDXM 200/20	CDX 200/20	1.5	2.0	
-	CDX 200/25	1.8	2.5	

* Mean value of several measures at 1m distance around the pump.

Tolerance ± 2.5 dB.