

Flamco XStream dirt separators ensure lower energy consumption, less wear and tear, fewer breakdowns, a longer lifespan and thus a higher efficiency of heating and cooling installations.

Less wear, less maintenance.

The Flamco XStream Clean ensures optimal separation of dirt and magnetite. The result: less heat losses, less wear, less maintenance and a heating system that lasts longer.

Advantages

- With an unique ECO/ MAX mode.
In the ECO mode a part of the system water (partial flow) is led through the Flamco XStream.
In the MAX mode all the system water is led through the Flamco XStream.
- Up to 15% less energy consumption of the heating system.*
- Up to 6% more efficiency of the heating system.*
- The unit is 360 degree rotatable for ease of installation.
- No account needs to be taken of the flow direction of the installation. This prevents installation errors.
- Thanks to the powerful internal magnet, the Flamco XStream Clean and the Vent-Clean have a great attraction to magnetite.
- Insulation is an integral part of the design of the Flamco XStream. This reduces heat losses to a minimum.
- The intergrated service indicator indicates when the system was last flushed/vented in the MAX mode.

* Calculated according to the Hysopt method in a system with a gas boiler and manually operated radiator valves.

Technical Specifications

- Materials: brass and high-quality plastic.
- Minimum/Maximum operating temperature: -10 °C / 120 °C.
- Minimum/Maximum system pressure: 0,2 / 10 bar.
- Suitable for addition of glycol-based anti-freeze up to 50%.
- Minimum/Maximum flow velocity: 0.2 / 3 m/s.
- Medium pH: 5 / 10.
- Material: EPP insulation. λ : 0.036 W/m.
- Average thickness insulation: 20 mm.



Description	XStream Clean 1 1/2" F	
Order Code	11034	
GTIN	08712874110342	
Model	<u>Flamco XStream Clean</u>	
Connection	[DN]	40
	(A)	G 1 1/2" F
K_v^* [m ³ /h] (ECO)	14.8	
K_v^* [m ³ /h] (MAX)	63.0	
Weight [kg]	2.8	

* $K_v = Q / \sqrt{\Delta P}$ Q: Flow [m³/h] ΔP : Pressure loss over the product (1 bar)

Flow factor K_v : Rate of flow [m³/h] which results in a 1 bar pressure drop across the product. This is different then the maximum allowed flow rate of the product.

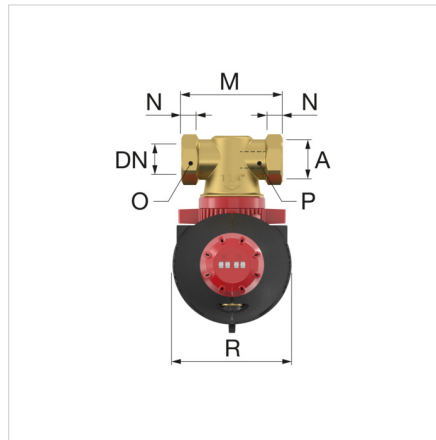
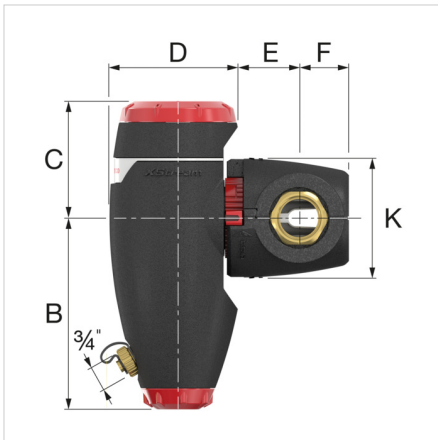

Flamco XStream Clean - Dimensions

Type	Dimensions										
	B [mm]	C [mm]	D [mm]	E [mm]	F [mm]	K [mm]	M [mm]	N [mm]	O [mm]	P [mm]	R [mm]
XStream Clean 22	149	98	106	44	41	102	119	24	32	24	114
XStream Clean 3/4 F	149	98	106	44	41	102	100	14	32	-	114
XStream Clean 1 M	149	98	106	44	41	102	100	13	-	27	114
XStream Clean 1 F	181	110	121	53	45	114	110	16	41	-	130
XStream Clean 1 1/4 M	181	110	121	53	45	114	110	14	-	34	130
XStream Clean 1 1/4 F	181	110	125	57	48	114	110	18	50	-	130
XStream Clean 1 1/2 F	208	124	139	62	51	132	129	18	55	-	145
XStream Clean 2 F	208	124	139	65	58	132	140	23	70	-	145

Classification General Data

Etim Group	Filters/separators
Etim Class	Air-/dirt separator for central heating/cooling system
Product Name	XStream Clean dirt separator with full and partial flow function and i
Brand	Flamco
Product Type	G 1 1/2"G 1 1/2"
Artikelnummer	11034

Attributes

Material	Plastic
Housing material	Brass
Housing material quality	Other
Separator type	Dirt
Model	Horizontal/vertical
Suitable for heating	Yes
Suitable for cooling	Yes
Nominal diameter	1 1/2 inch (40)
Outer pipe diameter	48.3 Millimetre
Connection	Internal thread cylindrical BSPP-G (ISO 228-1)
Construction length	129 Millimetre
Article compression class	PN 10
Surface protection	Untreated
Operating principle	Magnet
Suitable for open system	No
With blow-off valve	Yes
Suitable for closed system	Yes
With drain valve	Yes
With dismountable filter	No
Backwash filter	No
With automatic de-aerator	No
Max. medium temperature (continuous)	120 Degrees celsius
With integrated replenishment automat	No
With couplers	No
Inlet/outlet offset distance	0 Millimetre
Max. operating pressure	10 Bar
Magnet location	Internal
Variable flow direction	Yes
With insulation	Yes
Heat conduction coefficient insulation material (λ)	0.04 Watt per meter Kelvin

Find more information online:

[Installations and operating instructions](#)

[Statement of Conformity](#)

[XStream Clean DWG](#)

[XStream Clean STEP](#)

[XStream Clean RFA](#)

[Brochure \(English\)](#)

[Brochure \(Romanian\)](#)

[Leaflet \(English\)](#)

[Leaflet \(Romanian\)](#)

[Technical Handbook \(English\)](#)

[Export catalogue](#)

[Packaging data](#)

[Report Hysopt](#)

[XStream \(English\)](#)

[XStream \(Romanian\)](#)

[Explainer video XStream \(English\)](#)

[Explainer video XStream \(Romanian\)](#)

Fort Blauwkapel 1
1358 DB, Almere - nl

T +31 (0)36 52 62 300
E info@aalberts-hfc.com
I flamcogroup.com