

Technical data

Pump name

CMA 0.50 T

Customer	Date 2021-05-12	Company
Contact	Item no.	Issued by
Phone	Project	Phone
E-mail	Project ID	E-mail

Requested data

1	Pump type	CENTRIFUGAL PUMPS	Fluid	Water
2	Number of pumps / Reserve	1 / 0	Liquid temperature	°C 20
3	Flow m³/h		Kin. viscosity	cSt 1.005
4	Head m		Vapour pressure	kPa 2.34
5	Geodetic head m		PH value	
6	Inlet pressure (pin) kPa	0	Density	kg/m³ 998.3
7	Available system NPSH		Solids	Weight % 0
8	Ambient temperature °C	20		

Pump

9	Pump name	CMA 0.50 T	Frequency	Hz 50
10	Design	CENTRIFUGAL PUMPS	Installation type	STANDARD
11	Manufacturer	EBARA	Impeller Diameter	Max. mm 130
12	Speed rpm	2800		Designed mm 130
13	No. of Stage	1		Min. mm 130
14	Connection Suction side	UNI ISO 228	Flow	Operating m³/h
15	Connection Discharge side	UNI ISO 228		Max- m³/h 5.4
16	Max Working Pressure kPa	600		Min- m³/h 1.2
17	Shut-off head kPa	212.53	Head	Operating m
18	Total weight kg	See the table of "Dimensions".		- (Qmax.) m 13.1
19	Shaft power kW			- (Qmin.) m 20.9
20			Max. Shaft Power at max. impeller	kW 0.40
21	Required pump NPSH m		Efficiency	%

Materials

22	Impeller	PPE+PS glass fibre reinforced		
23	Casing	Cast iron		
24	Shaft	AISI 416 (integral)		
25				
26				
27				

Motor

28	Manufacturer	EPE Standard	Insulation class	F
29	Type	TEFC_CMA 0.50 M_230_Single Phase	Phases	1~
30	Specific design	- / 50 Hz / Pole pairs 1	Frame size	
31	Rated power kW	0.37	Weight	kg
32	Number of poles	2	Electric voltage	V 230
33	Speed rpm	2800	Electric current	A 3.2
34	Degree of protection	IP 44		
35				

Remarks

Performance curve

Pump name

CMA 0.50 T

Customer	Date	2021-05-12	Company
Contact	Item no.		Issued by
Phone	Project		Phone
E-mail	Project ID		E-mail

Requested data

1	Flow	m³/h	
2	Head	m	
3	Geodetic head	m	

Pump

Operating Flow	m³/h		Frequency	Hz	50
Operating Head	m		Number of poles		2
Impeller Diameter Designed	mm	130	Speed	rpm	2800

Test standard: ISO 9906:2012 - Grade3B

Water; 20°C; 998.3kg/m³; 1cSt

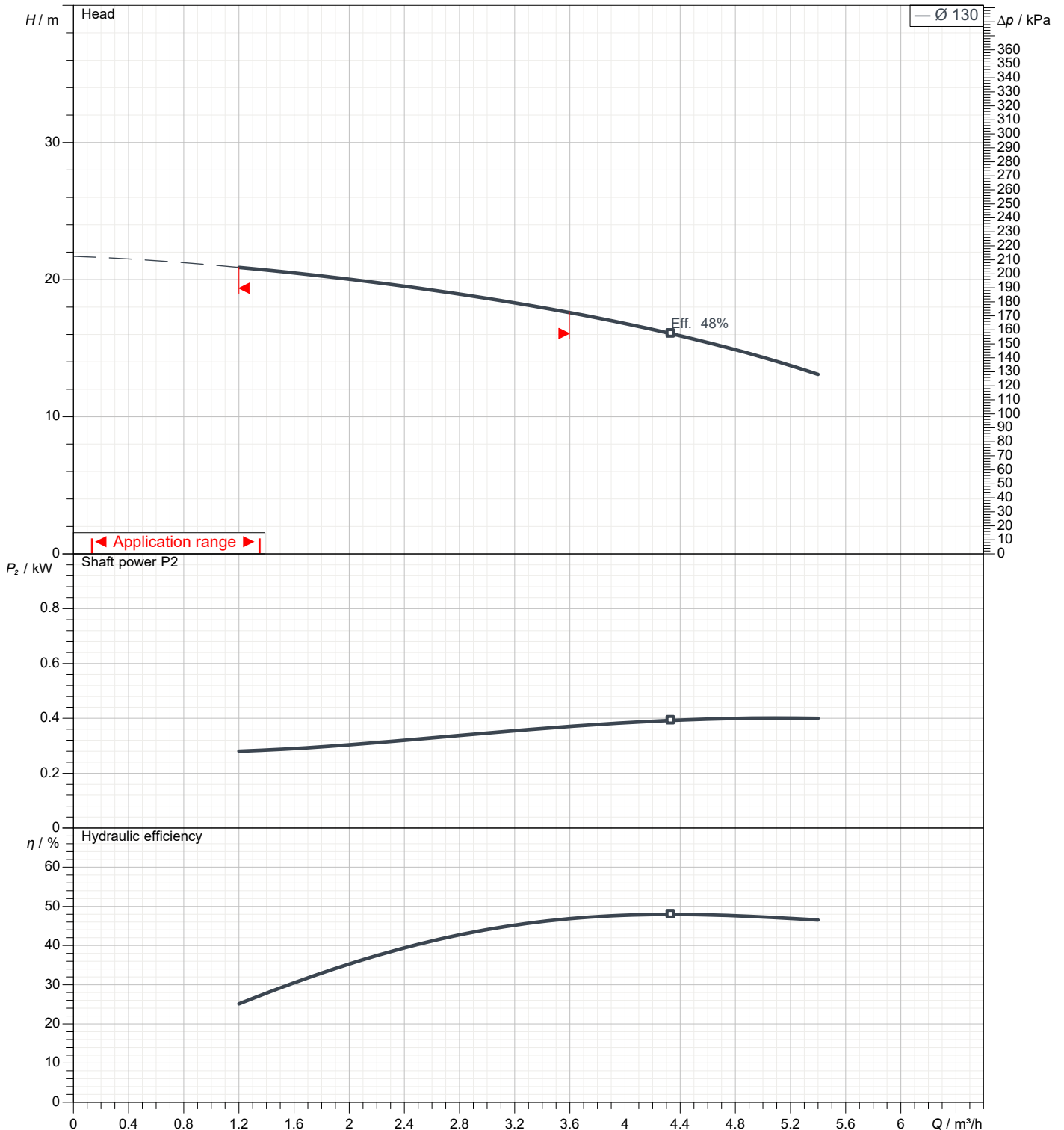

Dimensions

Pump name CMA 0.50 T

Customer	Date 2021-05-12	Company
Contact	Item no.	Issued by
Phone	Project	Phone
E-mail	Project ID	E-mail

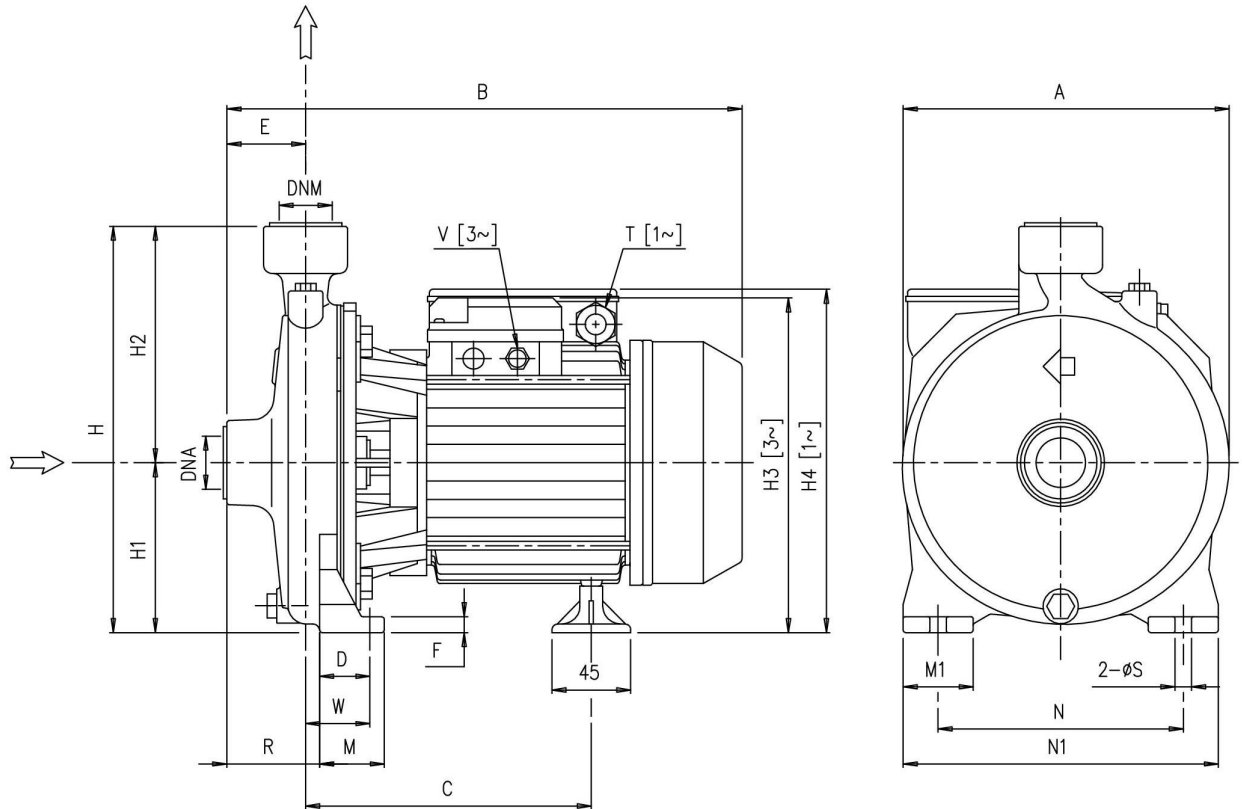

[1~] Single phase
[3~] Three phase

Dimensions in		mm						
1	A	160	N1	150				
2	B	261.8	R	44				
3	C	158.8	S	9.5				
4	D	30	V	PG 11				
5	DNA	G 1	W	30				
6	DNM	G 1	Weight P&M	7,1 kg				
7	E	44						
8	F	8						
9	H	202						
10	H1	82						
11	H2	120						
12	H3	172.5						
13	M	40						
14	M1	40						
15	N	110						

(1/3)

Construction

Pump name CMA 0.50 T

Customer	Date 2021-05-12	Company
Contact	Item no.	Issued by
Phone	Project	Phone
E-mail	Project ID	E-mail

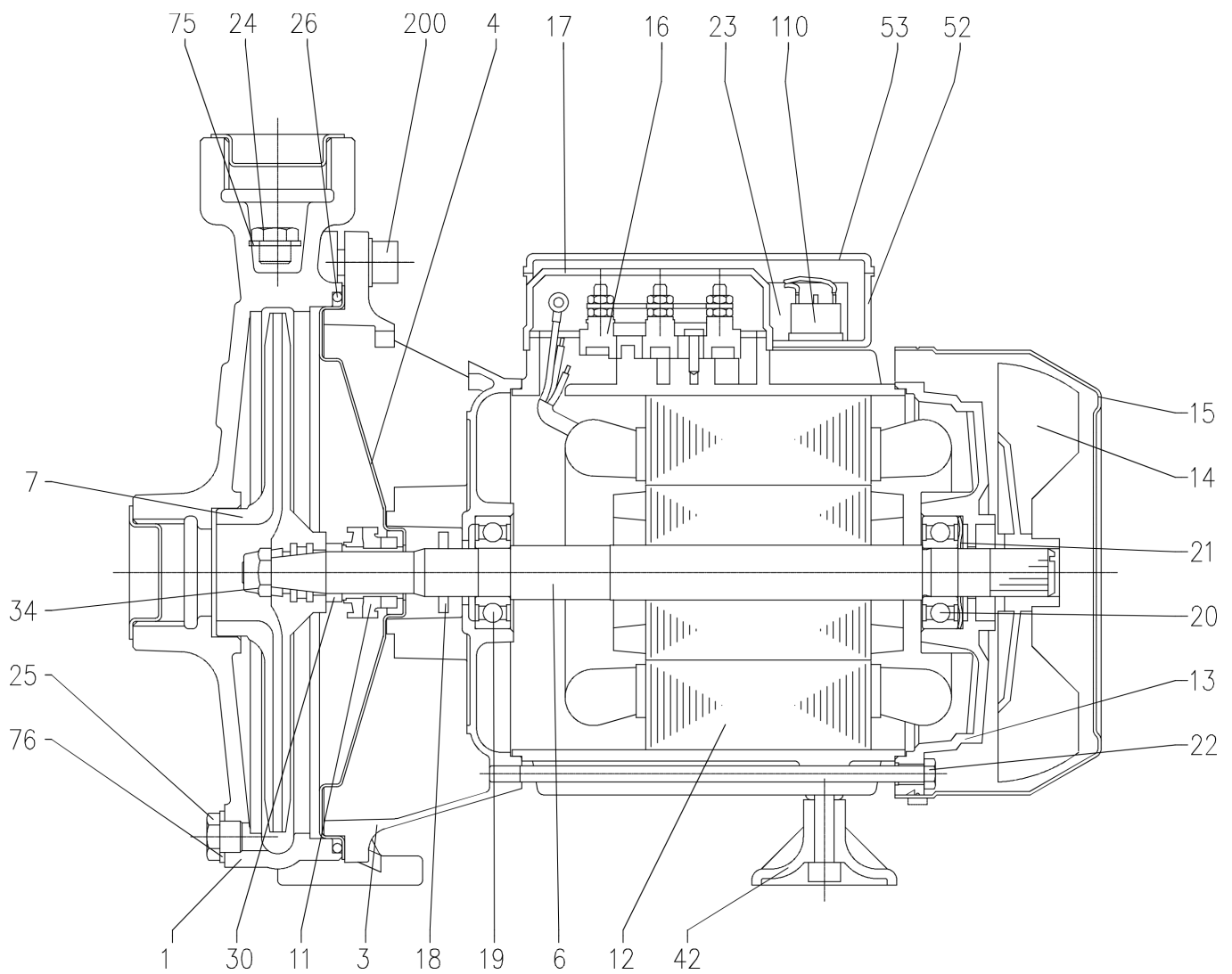

(2/3)**Construction**Pump name **CMA 0.50 T**

Customer	Date	2021-05-12	Company
Contact	Item no.		Issued by
Phone	Project		Phone
E-mail	Project ID		E-mail

N°	PART NAME		MATERIAL	DIMENSIONS	STANDARD	Q.TY
1	Casing		Cast iron			1
3	Motor bracket		Aluminium			1
4	Casing cover		AISI 304			1
6	Shaft with rotor		[1]			1
7	Impeller		[2]			1
11	Mechanical seal [7]		Carbon/Ceramic/NBR			1
12	Motor frame with stator		-			1
13	Motor cover		Aluminium			1
14	Fan		PA			1
15	Fan cover		Fe P04 Galvanized			1
16	Terminal box		-			1
17	Terminal box cover [3]		Aluminium			1
18	Splash ring	CMA 0.50 other models	NBR	D25x11.5x2.5 D25x14.5x2.5	EBARA DRAWING	1
19	Pump side ball bearing		-			1
20	Fan side ball bearing		-			1
21	Adjusting ring		Steel C70			1
22	Tie rod		Fe 42 Galvanized			4
23	Capacitor [4]		-			1
24	Priming plug		Brass	G 1/8"	UNI 338	1
25	Drain plug		Brass	G 1/8"	UNI 338	1
26	O-ring		NBR			1
30	Mechanical seal spacer [5]		Brass			1
34	Impeller nut [6]		AISI 304	M8x1	UNI7474	1
42	Foot		PP			1
52	Capacitor box [4]		ABS class V-0			1
53	Capacitor box cover [4]		ABS class V-0			1
75	Washer		Aluminium	10x16x1.5		1
76	Washer		Aluminium	10x16x1.5		1
110	Protector [4]		-			-
200	Screw	CMA 0.50 CMA 0.75; 1.00 CMC 0.75; 1.00 CMB 0.75; 1.00	Zn Steel Cl. 8.8	M6x16 M8x18 M8x22	ISO 898-1	4

- [1] Material: AISI 416 (integral) for CMA 0.50
AISI 303 (wet extension) for other model;
- [2] Material: PPE+PS glass fibre reinforced for version CMA
Cast iron for version CMB, CMC;
- [3] Only for three phase
- [4] Only for single phase
- [5] Only for version: CMA 0.50, CMB 0.75-1.00, CMC 0.75-1.00
- [6] Except for CMA 0.50
- [7] See **CONSTRUCTION 3**

(3/3)

Construction

Pump name CMA 0.50 T

Customer	Date 2021-05-12	Company
Contact	Item no.	Issued by
Phone	Project	Phone
E-mail	Project ID	E-mail

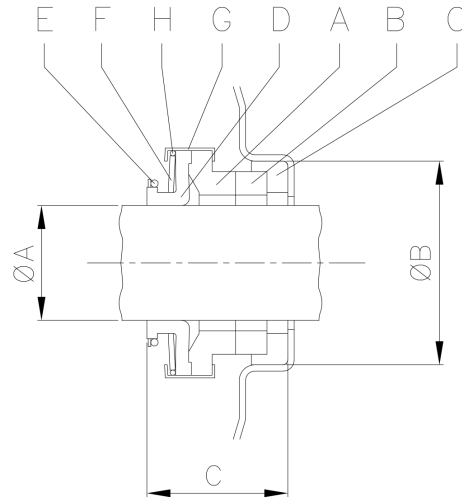

Pump type		Dimensions mm		
Single phase	Three phase	Ø A	Ø B	C
CMA 0.50 M	CMA 0.50 T	12	26	18.3

REF	PART NAME	MATERIAL product standard
A	Rotary seal ring	carbon graphite
B	Stationary seal ring	ceramic
C	Gasket	NBR
D	Bellows	NBR
E	Ring	AISI 304
F	Self driving spring	AISI 304
G	Frame	AISI 304
H	Retainer ring	AISI 304