

Technical data

Pump name

BEST 2

Customer	Date	2021-05-26	Company
Contact	Item no.		Issued by
Phone	Project		Phone
E-mail	Project ID		E-mail

Requested data

1	Pump type		SUBMERSIBLE SUMP PUMPS	Fluid		Water
2	Number of pumps / Reserve	1 / 0		Liquid temperature	°C	20
3	Flow	m³/h		Kin. viscosity	cSt	1.005
4	Head	m		Vapour pressure	kPa	2.34
5	Geodetic head	m		PH value		
6	Inlet pressure (pin)	kPa	0	Density	kg/m³	998.3
7	Available system NPSH			Solids	Weight %	0
8	Ambient temperature	°C	20			

Pump

9	Pump name	BEST 2	Frequency	Hz	50
10	Design	SUBMERSIBLE SUMP PUMPS	Installation type		Without switch (STANDARD)
11	Manufacturer	EBARA	Impeller Diameter	Max.	mm 112
12	Speed	rpm 2800		Designed	mm 112
13	No. of Stage	1		Min.	mm 112
14	Connection Suction side	Strainer	Flow	Operating	m³/h
15	Connection Discharge side	UNI ISO 228		Max-	m³/h 15.6
16	Max Working Pressure	kPa		Min-	m³/h 1.2
17	Shut-off head	kPa 128.39	Head	Operating	m
18	Total weight	kg		- (Qmax.)	m 2.9
19	Shaft power	kW		- (Qmin.)	m 12.2
20			Max. Shaft Power at max. impeller	kW	
21	Required pump NPSH	m	Efficiency	%	

Materials

22	Impeller	AISI 304		
23	Casing	AISI 304		
24	Shaft	AISI 303 (wet extension)		
25				
26				
27				

Motor

28	Manufacturer	EPE Standard	Insulation class	F
29	Type	BEST2_400_Three Phase	Phases	3~
30	Specific design	Submersible dry type / 50 Hz / Pole pairs 1	Frame size	
31	Rated power	kW 0.55	Weight	kg
32	Number of poles	2	Electric voltage	V 400
33	Speed	rpm 2800	Electric current	A 2
34	Degree of protection	IP 68		
35				

Remarks

Performance curve

Pump name

BEST 2

Customer	Date 2021-05-26	Company
Contact	Item no.	Issued by
Phone	Project	Phone
E-mail	Project ID	E-mail

Requested data

1	Flow	m ³ /h	
2	Head	m	
3	Geodetic head	m	

Pump

Operating Flow	m ³ /h	Frequency	Hz	50	
Operating Head	m	Number of poles	2		
Impeller Diameter Designed	mm	112	Speed	rpm	2800

Test standard: ISO 9906:2012 - Grade3B

Water; 20°C; 998.3kg/m³; 1cSt

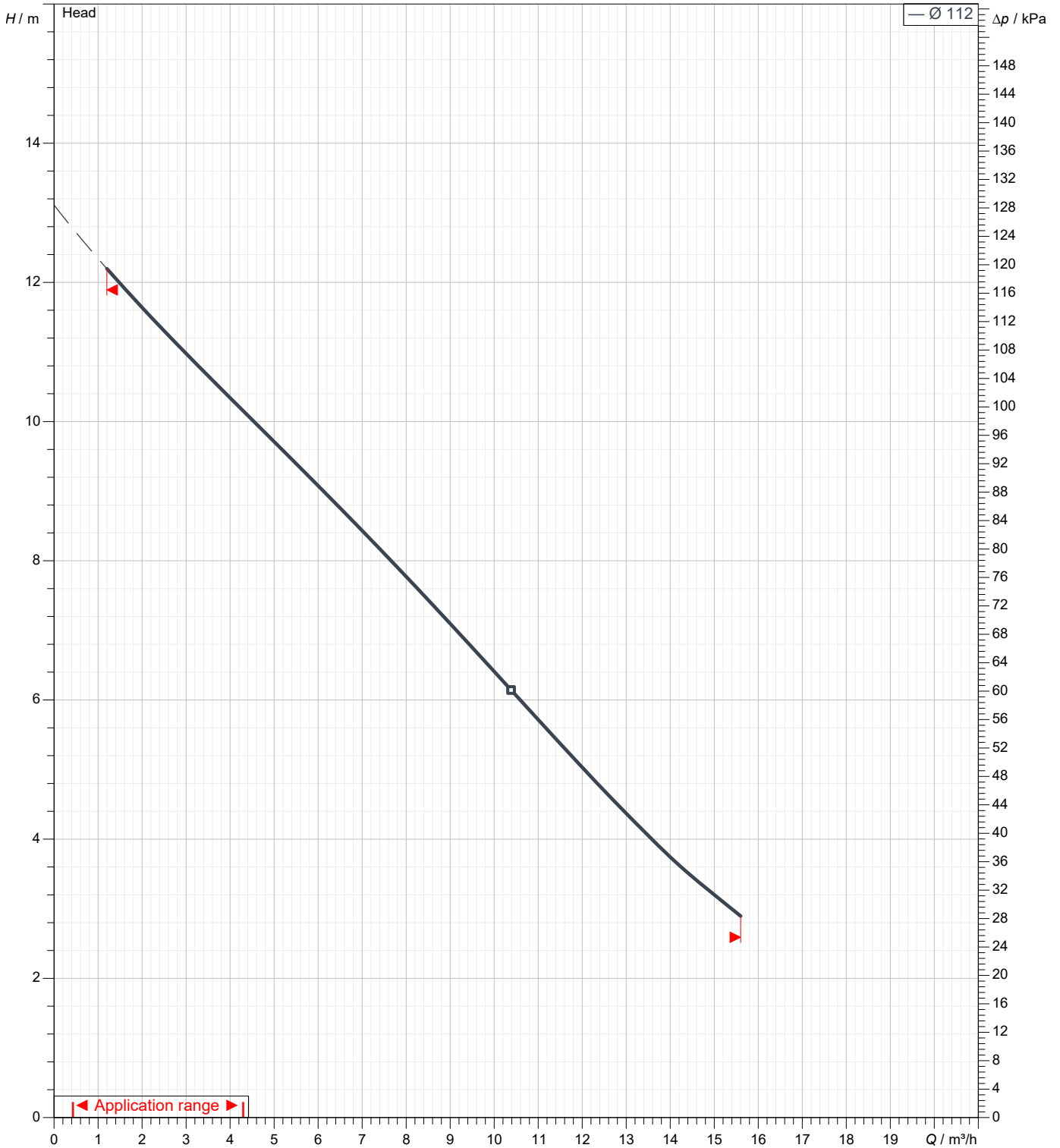

Dimensions

Pump name BEST 2

Customer	Date 2021-05-26	Company
Contact	Item no.	Issued by
Phone	Project	Phone
E-mail	Project ID	E-mail

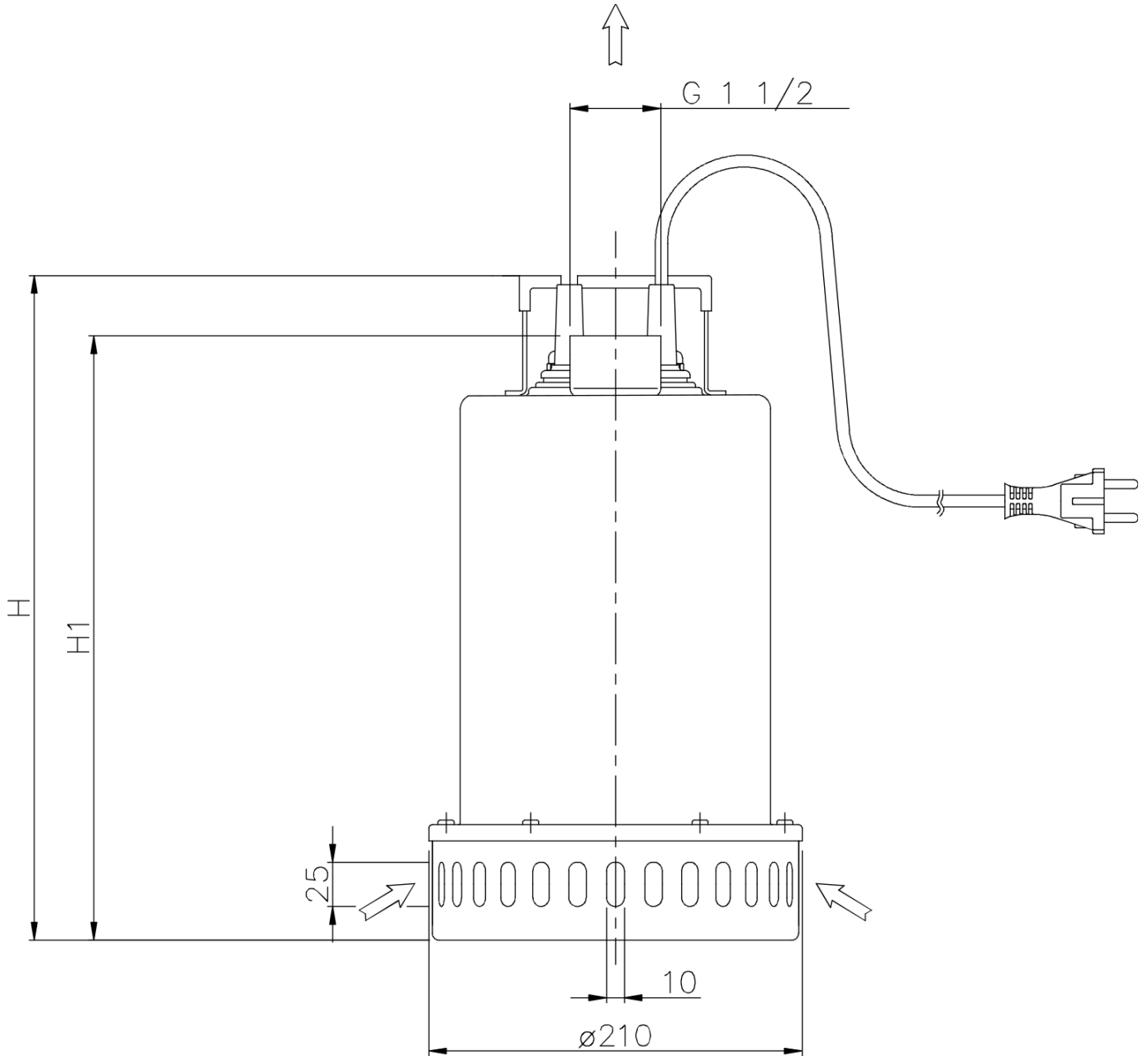

Dimensions in		mm						
1	H	352						
2	H1	315						
3	Weight P&M	12 kg						
4								
5								
6								
7								
8								
9								
10								
11								
12								
13								
14								
15								

(1/3) Construction

Pump name BEST 2

Customer	Date 2021-05-26	Company
Contact	Item no.	Issued by
Phone	Project	Phone
E-mail	Project ID	E-mail

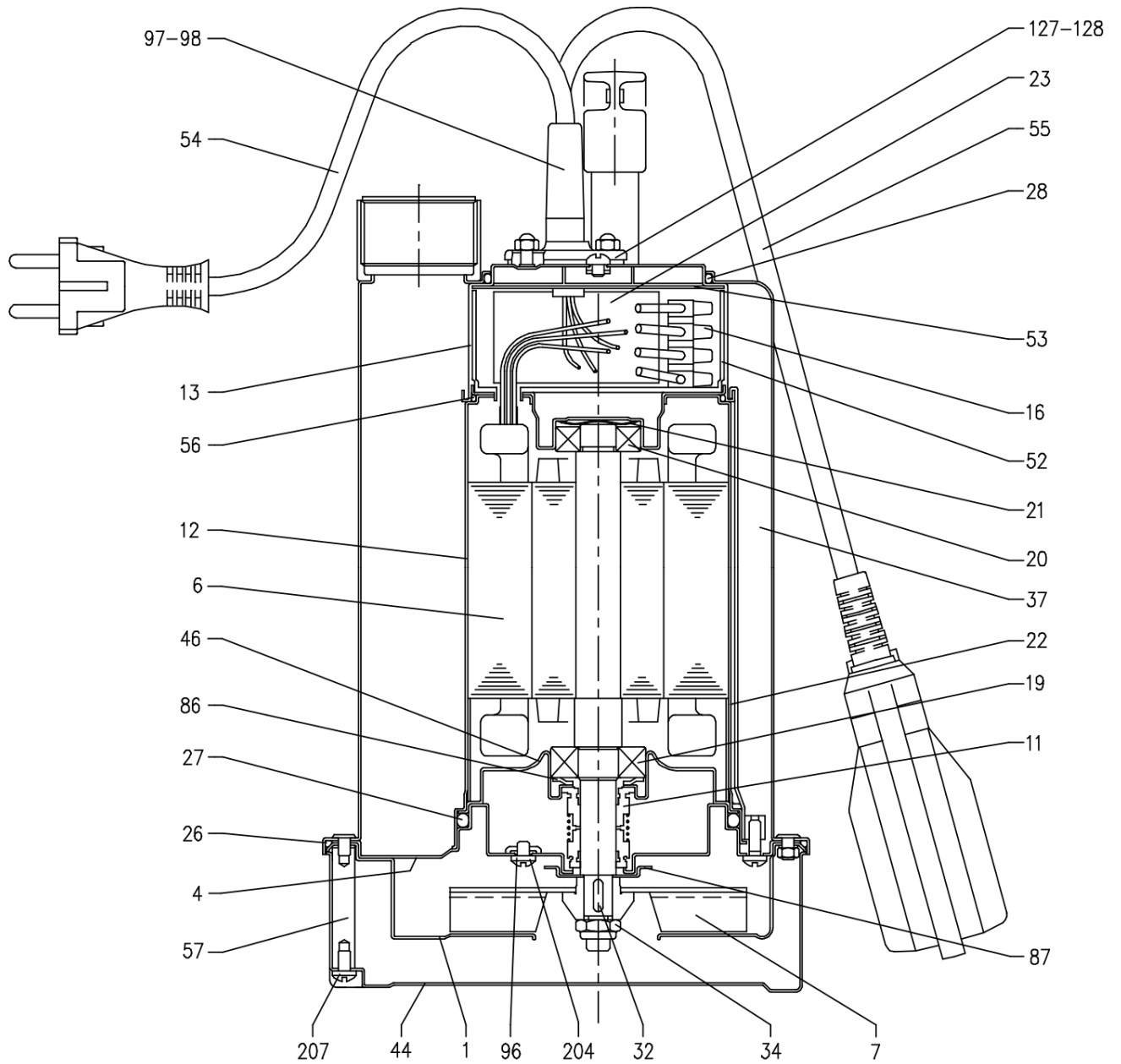

(2/3)**Construction**Pump name **BEST 2**

Customer	Date 2021-05-26	Company
Contact	Item no.	Issued by
Phone	Project	Phone
E-mail	Project ID	E-mail

N°	PART NAME	MATERIAL	Q.TY
1	Volute	AISI 304	1
4	Motor bracket	AISI 304	1
6	Shaft with rotor	AISI 303	1
7	Impeller	AISI 304	1
11	Mechanical seal [3]	NBR	2
12	Motor frame with stator	-	1
13	Motor cover	AISI 304	1
16	Terminal	-	1
19	Pump side ball bearing	-	1
20	Fan side ball bearing	-	1
21	Adjusting ring	Steel C70	1
22	Tie rod	AISI 304	3
23	Capacitor [2]	-	1
26	"O" Ring	NBR	1
27	"O" Ring	NBR	1
28	"O" Ring	NBR	1
32	Key	AISI 304	1
34	Impeller nut	AISI 304	1
37	Pump casing	AISI 304	1
44	Strainer	AISI 304	1
46	Bearing housing	AISI 304	1
52	Terminal insulating box	PA66 glass fibre reinforced class V-0	1
53	Terminal insulating cover	PA66 class V-0	1
54	Power cable	-	1
55	Float switch [1]	-	1
56	"O" Ring	NBR	1
57	Bolt	AISI 303	3
86	Washer	AISI 304	1
87	Impeller ring	AISI 304	1
96	"O" Ring	NBR	3
97	Cable connector [1]	NBR	1
98	Cable connector	NBR	1
127	Cable connector [1]	AISI 304	1
128	Cable connector	AISI 304	1
204	Screw	Stainless steel A2 UNI 7323	3
207	Screw	Stainless steel A2 UNI 7323	3

[1] Only for version single phase with float switch

[2] Only for version single phase

[3] See **CONSTRUCTION 3**

(3/3)

Construction

Pump name BEST 2

Customer	Date 2021-05-26	Company
Contact	Item no.	Issued by
Phone	Project	Phone
E-mail	Project ID	E-mail

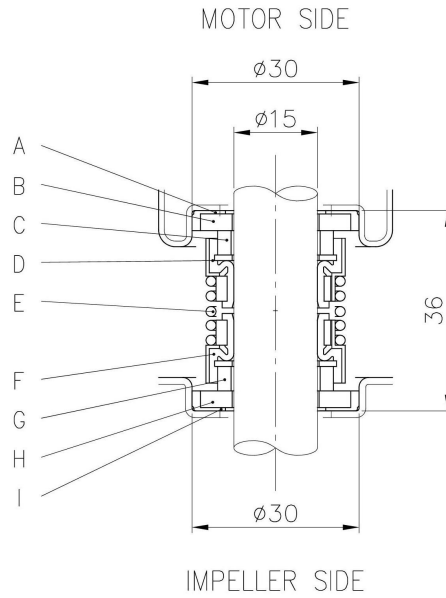

REF	PART NAME	MATERIAL
A	Rubber cup	NBR
B	Seat	Ceramic
C	Seal face	Carbon
D	Belw	NBR
E	Spring	AISI 304
F	Belw	NBR
G	Seal face	Silicon carbide
H	Seat	Silicon carbide
I	Rubber cup	NBR