

Technical data

Pump name

CD 120/07

Customer	Date	2021-05-12	Company
Contact	Item no.		Issued by
Phone	Project		Phone
E-mail	Project ID		E-mail

Requested data

1	Pump type	CENTRIFUGAL PUMPS	Fluid	Water
2	Number of pumps / Reserve	1 / 0	Liquid temperature	°C 20
3	Flow m³/h		Kin. viscosity	cSt 1.005
4	Head m		Vapour pressure	kPa 2.34
5	Geodetic head m		PH value	
6	Inlet pressure (pin) kPa	0	Density	kg/m³ 998.3
7	Available system NPSH		Solids	Weight % 0
8	Ambient temperature °C	20		

Pump

9	Pump name	CD 120/07	Frequency	Hz 50
10	Design	CENTRIFUGAL PUMPS	Installation type	STANDARD
11	Manufacturer	EBARA	Impeller Diameter	Max. mm 132
12	Speed rpm	2800		Designed mm 132
13	No. of Stage	1		Min. mm 132
14	Connection Suction side	UNI ISO 228-1	Flow	Operating m³/h
15	Connection Discharge side	UNI ISO 228-1		Max- m³/h 10.8
16	Max Working Pressure kPa	800		Min- m³/h 3
17	Shut-off head kPa	220.32	Head	Operating m
18	Total weight kg	See the table of "Dimensions".		- (Qmax.) m 12.5
19	Shaft power kW			- (Qmin.) m 20.5
20			Max. Shaft Power at max. impeller	kW 0.64
21	Required pump NPSH m		Efficiency	%

Materials

22	Impeller	AISI 304	
23	Casing	AISI 304	
24	Shaft	AISI 303 (Wet extension)	
25			
26			
27			

Motor

28	Manufacturer	EPE Standard	Insulation class	F
29	Type	TEFC_CD 120/07_230_Three Phase	Phases	3~
30	Specific design	- / 50 Hz / Pole pairs 1	Frame size	
31	Rated power kW	0.55	Weight	kg
32	Number of poles	2	Electric voltage	V 230
33	Speed rpm	2800	Electric current	A 3.2
34	Degree of protection	IP 55		
35				

Remarks

Performance curve

Pump name

CD 120/07

Customer	Date	2021-05-12	Company
Contact	Item no.		Issued by
Phone	Project		Phone
E-mail	Project ID		E-mail

Requested data

1	Flow	m³/h	
2	Head	m	
3	Geodetic head	m	

Pump

Operating Flow	m³/h		Frequency	Hz	50
Operating Head	m		Number of poles		2
Impeller Diameter Designed	mm	132	Speed	rpm	2800

Test standard: ISO 9906:2012 - Grade3B

Water; 20°C; 998.3kg/m³; 1cSt

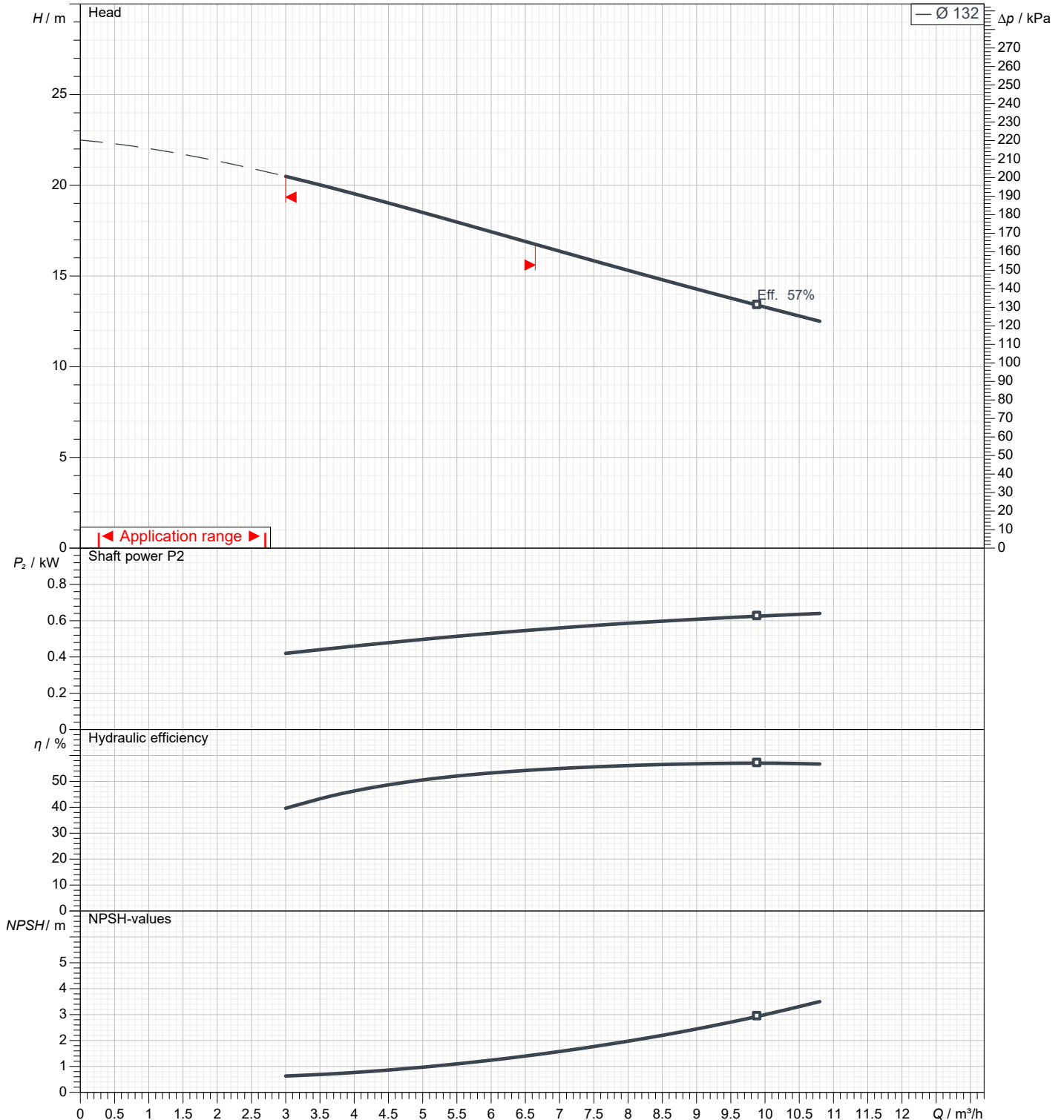

Dimensions

Pump name CD 120/07

Customer	Date 2021-05-12	Company
Contact	Item no.	Issued by
Phone	Project	Phone
E-mail	Project ID	E-mail

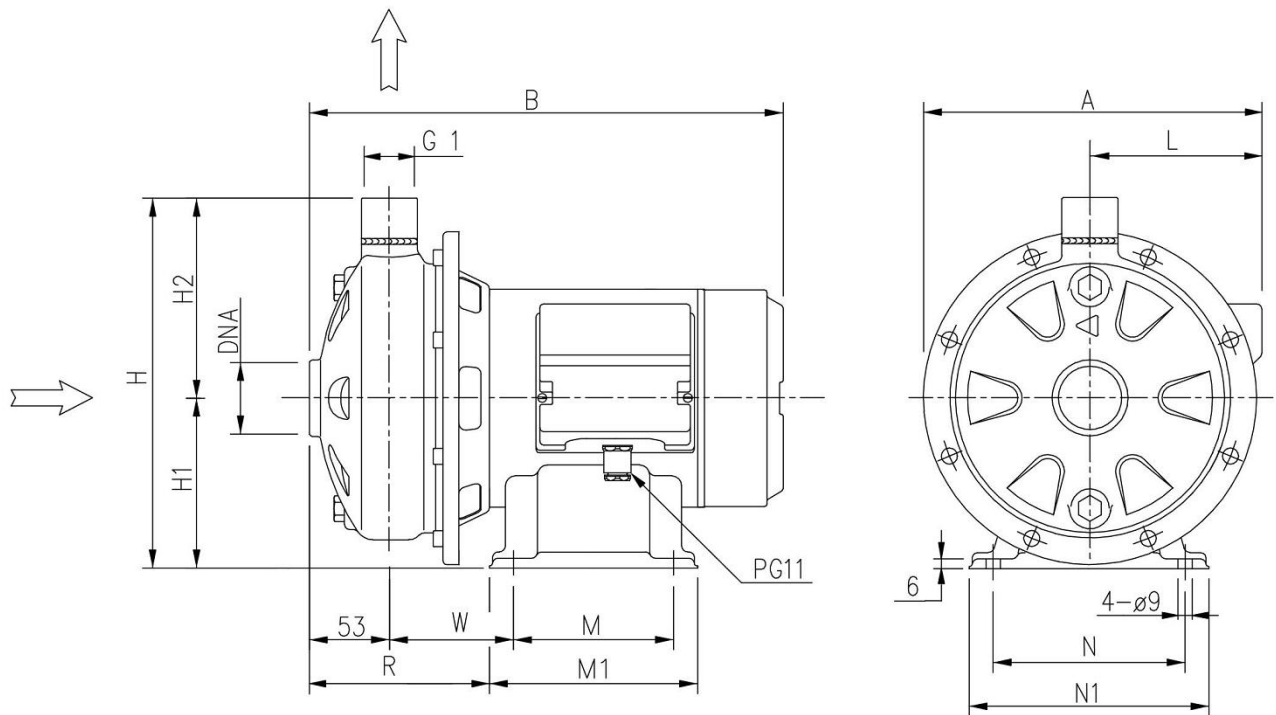

Dimensions in		mm						
1	A	208						
2	B	298						
3	DNA	G 1" 1/4						
4	H	229.5						
5	H1	106						
6	H2	123.5						
7	L	104						
8	M	100						
9	M1	130						
10	N	120						
11	N1	150						
12	R	115.5						
13	W	77.5						
14	Weight P&M	[10].5kg						
15								

(1/3)

Construction

Pump name CD 120/07

Customer	Date 2021-05-12	Company
Contact	Item no.	Issued by
Phone	Project	Phone
E-mail	Project ID	E-mail

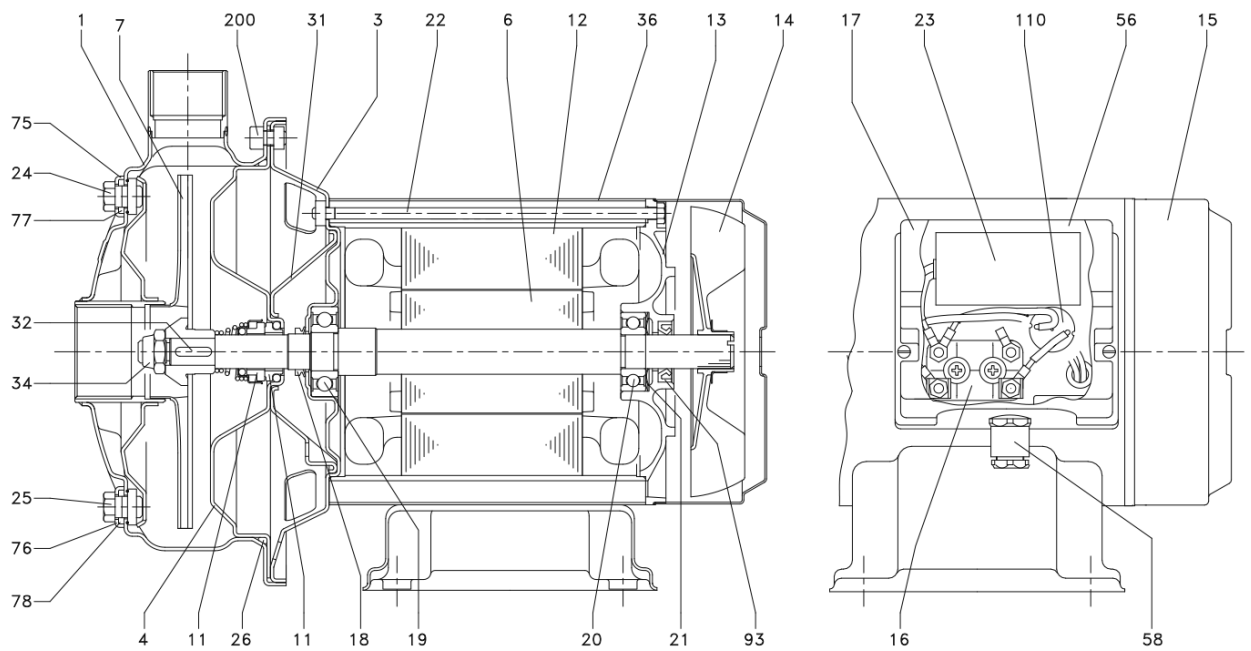

(2/3)

Construction

Pump name CD 120/07

Customer	Date 2021-05-12	Company
Contact	Item no.	Issued by
Phone	Project	Phone
E-mail	Project ID	E-mail

N°	PART NAME	MATERIAL	DIMENSION	STANDARD	Q.TY
1	Casing	AISI 304			1
3	Motor bracket	AISI 304			1
4	Casing cover	AISI 304			1
6	Shaft with rotor	AISI 303 (Wet extension)			1
7	Impeller	AISI 304			1
11	Mechanical seal [3]	Ceramic/Carbon/NBR			1
12	Motor frame with stator	-			1
13	Motor cover	Aluminium			1
14	Fan	PA			1
15	Fan cover	AISI 304			1
16	Terminal board	-			1
17	Terminal box cover	PA66 glass fibre reinforced class V-0			1
18	Splash ring	NBR			1
19	Pump side ball bearing	-			1
20	Fan side ball bearing	-			1
21	Adjusting ring	Steel C70			1
22	Tie rod	Fe 420 Galvanized			4
23	Capacitor [1]	-			1
24	Priming plug	AISI 304			1
25	Drain plug	AISI 304			1
26	O-ring [2]	NBR			1
31	Thrust flange	AISI 304			1
32	Key	AISI 316	4x4x14	UNI 6604	1
34	Impeller nut	Stainless steel A2-70	M10X1,25	UNI 7474	1
36	Motor casing	AISI 304			1
56	Box gasket	NBR			1
58	Cable entry	-			1
73	Casing ring	-			1
75	Washer	AISI 304			1
76	Washer	AISI 304			1
77	O-ring [2]	NBR			1
78	O-ring [2]	NBR			1
93	Lip seal	NBR			1
110	Protector [1]	-			1
200	Screw	120/07 70/12, 120/20	Stainless steel A2-70	M6X12 M8X14	UNI 5931 8

- [1] Only for single phase
- [2] FPM for H-HS-HW-HSW
EPDM for E and Special Mechanical Seal
- [3] See **CONSTRUCTION 3**

(3/3)

Construction

Pump name CD 120/07

Customer	Date 2021-05-12	Company
Contact	Item no.	Issued by
Phone	Project	Phone
E-mail	Project ID	E-mail

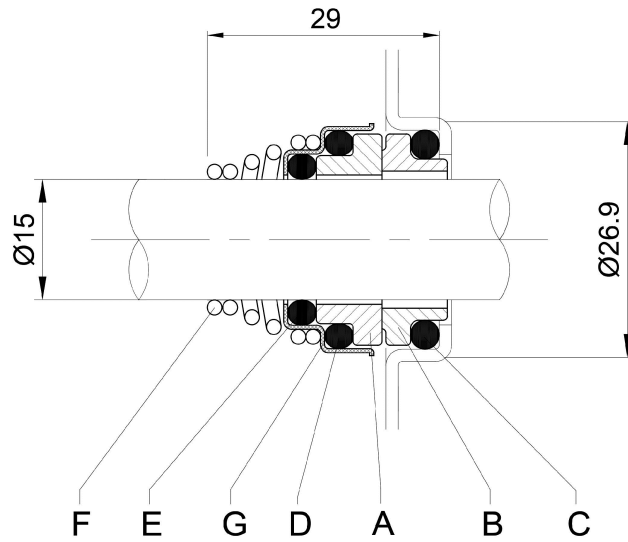

REF	PART NAME	MATERIAL Standard and L version
A	Rotary seal ring	Ceramic
B	Stationary seal ring	Carbon graphite
C	O-Ring	NBR
D	O-Ring	NBR
E	O-Ring	NBR
F	Self-driving spring	AISI 316
G	Frame	AISI 304