

Data sheet: TOP-Z 20/4 (3~400 V, PN 10, Inox)

Hydraulic data

Max. volume flow Q	4.0
Delivery head for Q_{min} H_{Qmin}	3.6

Motor data

Mains connection	3-230 V, 3~400 V, 50 Hz
Emitted interference	EN 61000-6-3
Interference resistance	EN 61000-6-2
Power consumption $P_{1 min}$	35 W
Power consumption $P_{1 max}$	100 W
Rated power P_2	60 W
Rated current I_N	0.35 A
Protection class motor	IPX4D
Motor protection	integrated
Insulation class	H
Max. speed n_{max}	2850 rpm
Threaded cable connection	1 x PG13.5

Materials

Shaft	Al2O3, Aluminum oxide
Pump housing	1.4031, X39Cr13
Impeller	PPE-GF30
Bearing	Carbon, synthetic resin impregnated

Product data

Maximum operating pressure PN	10 bar
Max. fluid temperature T	110 °C
Min. fluid temperature T	-20 °C
Max. ambient temperature T	40 °C
Max. permitted total hardness in domestic hot water circulation systems	3.57 mmol/l (20 °dH) (3.21 mmol/l (18 °dH) for 20/4 + 25/6)

Installation dimensions

Pipe connection on the suction side	G 1¼
Pipe connection on the pressure side	G 1¼
Port-to-port length l_0	150 mm

Information for order placements

Brand	Wilo
Product description	TOP-Z 20/4 (3~400 V, PN 10, Inox)
Article number	2045520
Net weight, approx. m	3 kg

Dimensions and dimensions drawings: TOP-Z 20/4 (3~400 V, PN 10, Inox)

TOP-Z

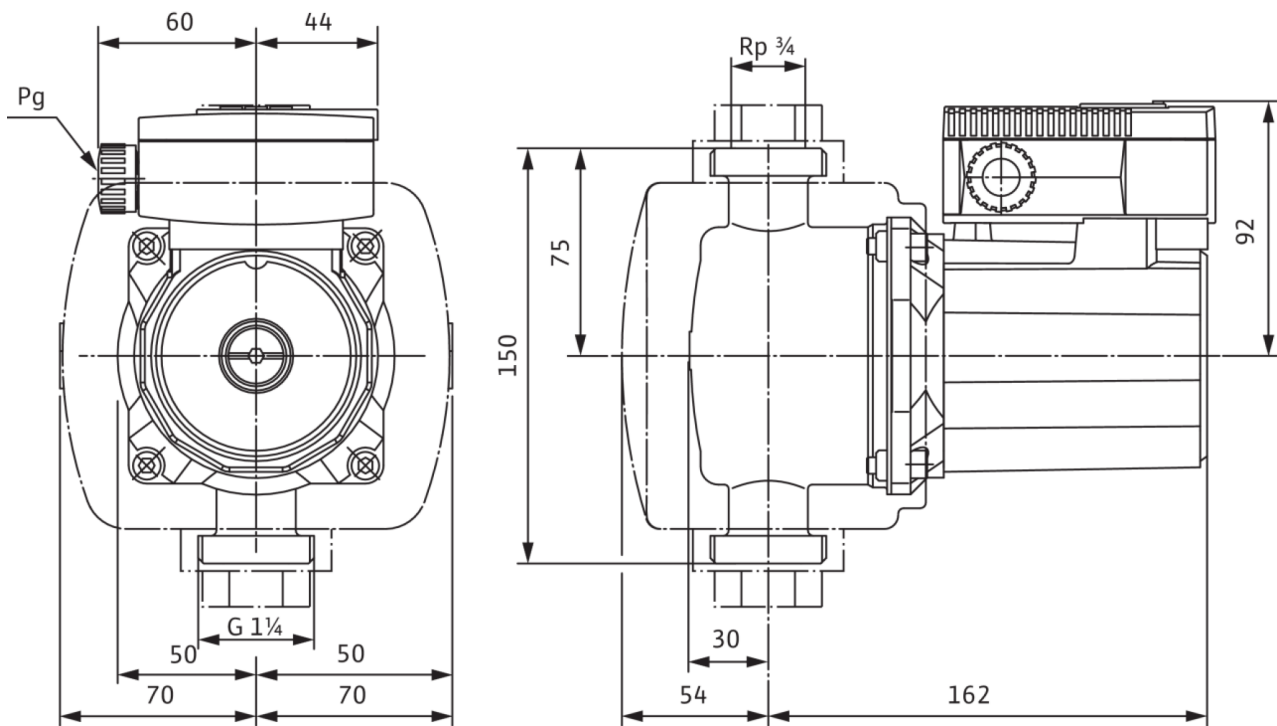

Pump curves: TOP-Z 20/4 (3~400 V, PN 10, Inox)

TOP-Z 20/4, 3~

