

Data sheet: TOP-Z 30/10 (1~230 V, PN 10, RG)

Hydraulic data

Max. volume flow Q	9.5
Delivery head for Q_{min} H_{Qmin}	9.3

Motor data

Mains connection	1~230 V, 50 Hz
Emitted interference	EN 61000-6-3
Interference resistance	EN 61000-6-2
Power consumption $P_{1 min}$	150 W
Power consumption $P_{1 max}$	335 W
Rated power P_2	180 W
Rated current I_N	1.62 A
Protection class motor	IPX4D
Motor protection	Optional SK 602N/622N tripping unit, Protect-Module C
Insulation class	H
Max. speed n_{max}	2800 rpm
Threaded cable connection	2 x PG13.5

Materials

Shaft	1.4122, X39CrMo17-1
Pump housing	Red brass
Impeller	PPE-GF30
Bearing	Carbon, synthetic resin impregnated

Product data

Maximum operating pressure PN	10 bar
Max. fluid temperature T	110 °C
Min. fluid temperature T	-20 °C
Max. ambient temperature T	40 °C
Max. permitted total hardness in domestic hot water circulation systems	3.57 mmol/l (20 °dH) (3.21 mmol/l (18 °dH) for 20/4 + 25/6)

Installation dimensions

Pipe connection on the suction side	G 2
Pipe connection on the pressure side	G 2
Port-to-port length l_0	180 mm

Information for order placements

Brand	Wilo
Product description	TOP-Z 30/10 (1~230 V, PN 10, RG)
Article number	2059857
Net weight, approx. m	7 kg

Dimensions and dimensions drawings: TOP-Z 30/10 (1~230 V, PN 10, RG)

TOP-S

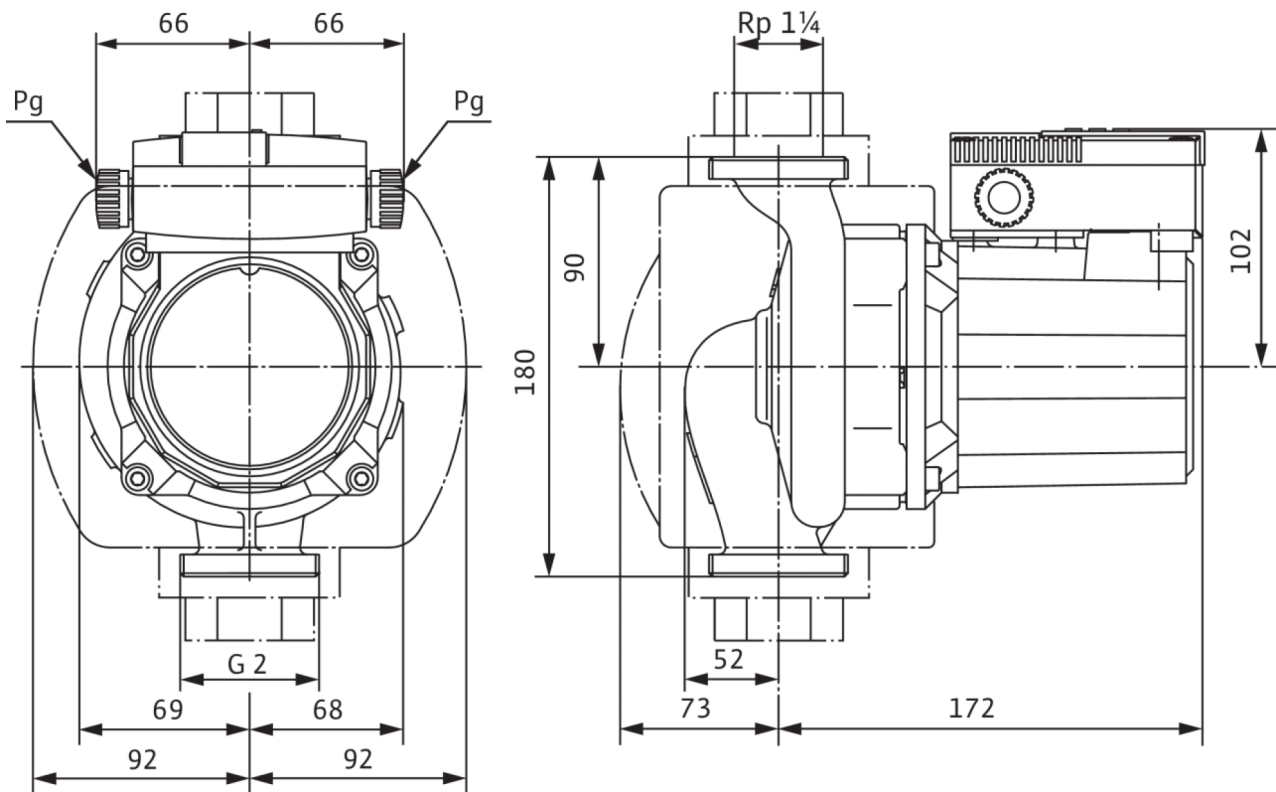

Pump curves: TOP-Z 30/10 (1~230 V, PN 10, RG)

TOP-Z 30/10, 1~

