

Technical Data

Pump Name

EVMS10 11N5Q1BEGE/4.0

Customer	Date	2022-04-19	Company
Contact	Item no.		Issued by
Phone	Project		Phone
E-mail	Project ID		E-mail

Requested data

1	Pump type	VERTICAL MULTISTAGE PUMP	Fluid	Water
2	Number of pumps / Reserve	1 / 0	Liquid temperature	°C 20
3	Flow	m³/h	Kin. viscosity	cSt 1.005
4	Head	m	Vapour pressure	kPa 2.34
5	Geodetic head	m	PH value	
6	Inlet pressure (pin)	kPa 0	Density	kg/m³ 998.3
7	Available system NPSH		Solids	Weight % 0
8	Ambient temperature	°C 20		

Pump

9	Pump Name	EVMS10 11N5Q1BEGE/4.0	Frequency	Hz 50
10	Design	VERTICAL MULTISTAGE PUMP	Installation type	Oval flange (STANDARD)
11	Manufacturer	EBARA	Impeller Diameter	Max. mm 96
12	Speed	rpm 2920		Designed mm 96
13	No. of Stage	11		Min. mm 96
14	Connection	Suction side	Flow	Operating m³/h
15	Connection	Discharge side		Max- m³/h 15
16	Max. Working Pressure	kPa 1600		Min- m³/h 4.5
17	Shut-off head	kPa 1189.68	Head	Operating m
18	Total weight	kg See the table of "Dimensions".		- (Qmax.) m 55.7
19	Shaft power	kW		- (Qmin.) m 118.3
20			Max. Shaft Power at max. impeller	kW 3.98
21	Required pump NPSH	m	Efficiency	%

Materials

22	Impeller	AISI 304	
23	Intermediate casing	AISI 304	
24	Bottom casing	AISI 304	
25	Shaft	AISI 304	
26	O-ring	EPDM	
27			

Motor

28	Manufacturer	ETM	Insulation class	F
29	Type	TEFC_EVMS10 11/4.0_230_Three Phase	Phases	3~
30	Specific design	IE3 / 50 Hz / Pole pairs 1	Frame size	112
31	Rated power	kW 4	Weight	kg 28.5
32	Number of poles	2	Electric voltage	V 230
33	Speed	rpm 2920	Electric current	A 15.1
34	Degree of protection	IP 55		
35				

Remarks

Performance Curve

Pump Name

EVMS10 11N5Q1BEGE/4.0

Customer	Date	2022-04-19	Company
Contact	Item no.		Issued by
Phone	Project		Phone
E-mail	Project ID		E-mail

Requested data

1	Flow	m³/h	
2	Head	m	
3	Geodetic head	m	

Pump

Operating Flow	m³/h		Frequency	Hz	50
Operating Head	m		Number of poles		2
Impeller diameter designed	mm	96	Speed	rpm	2920

Test standard: ISO 9906:2012 - Grade3B

Water; 20°C; 998.3kg/m³; 1cSt

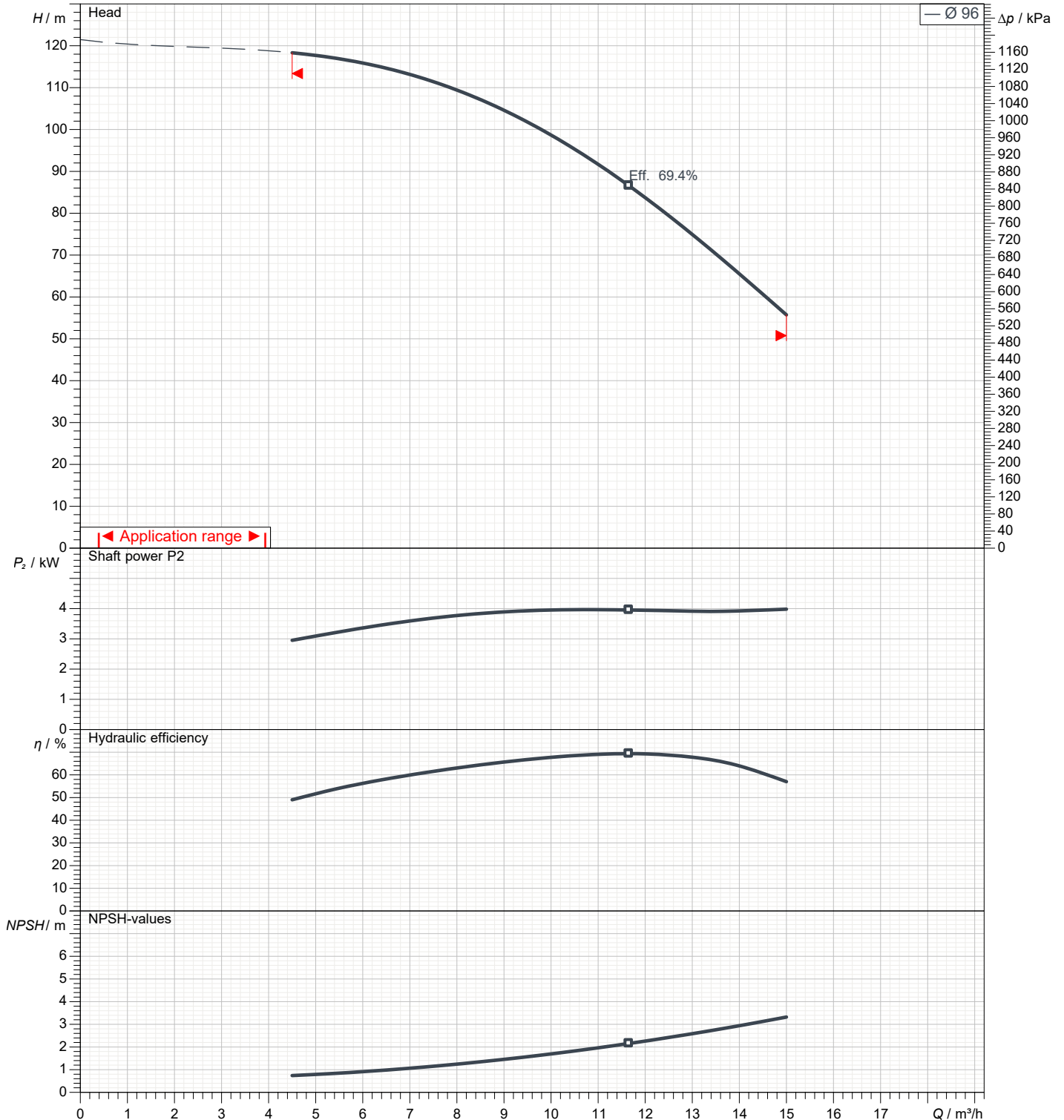

Dimensions

Pump name EVMS10 11N5Q1BEGE/4.0

Customer	Date 2022-04-19	Company
Contact	Item no.	Issued by
Phone	Project	Phone
E-mail	Project ID	E-mail

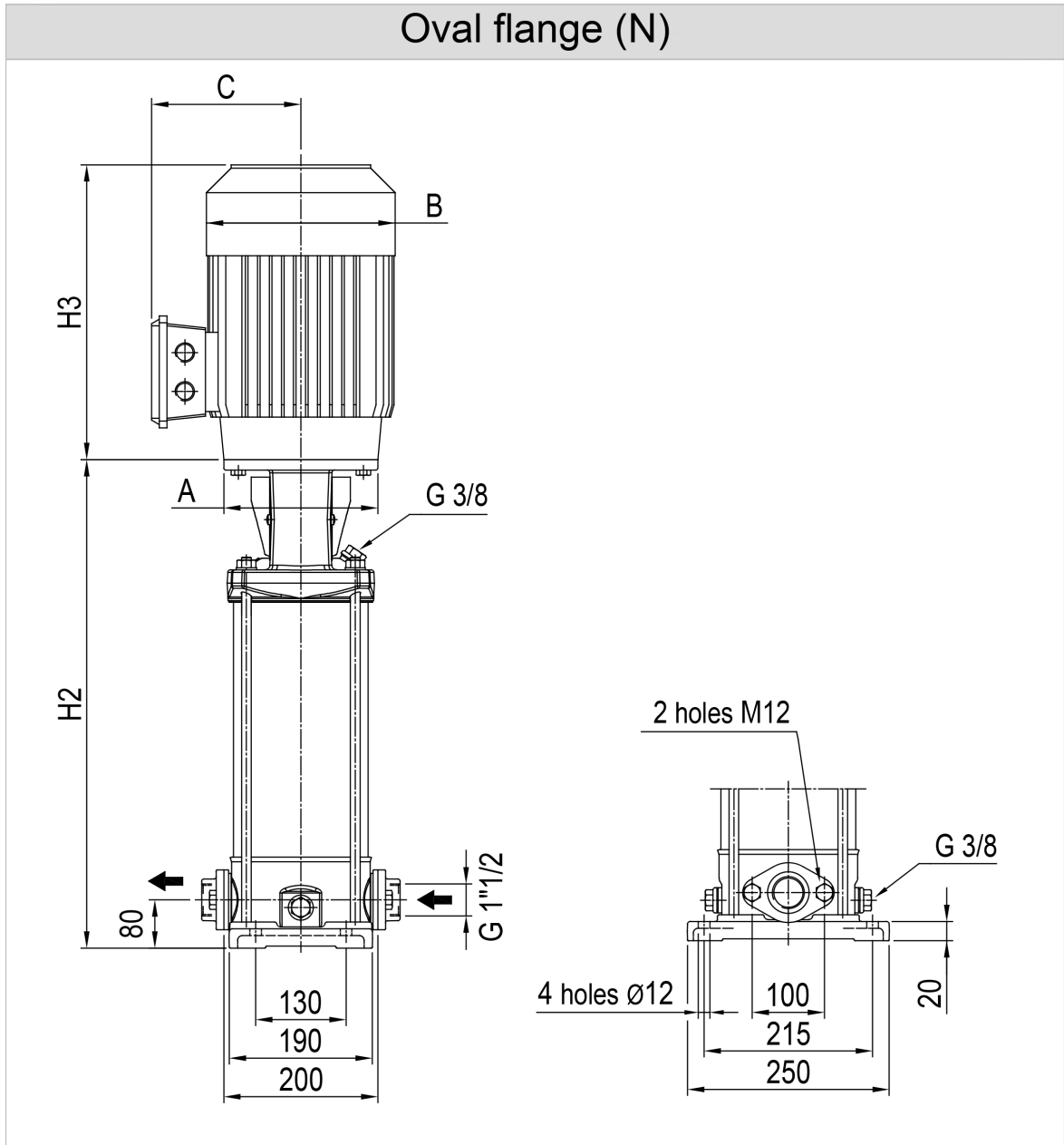

Dimensions in		mm						
1	A	Dia160						
2	B	193						
3	C	138						
4	H2	633						
5	H3	364						
6	Weight P&M (kg)	54.6						
7								
8								
9								
10								
11								
12								
13								
14								
15								

(1/4)

Construction

Pump name EVMS10 11N5Q1BEGE/4.0

Customer	Date 2022-04-19	Company
Contact	Item no.	Issued by
Phone	Project	Phone
E-mail	Project ID	E-mail

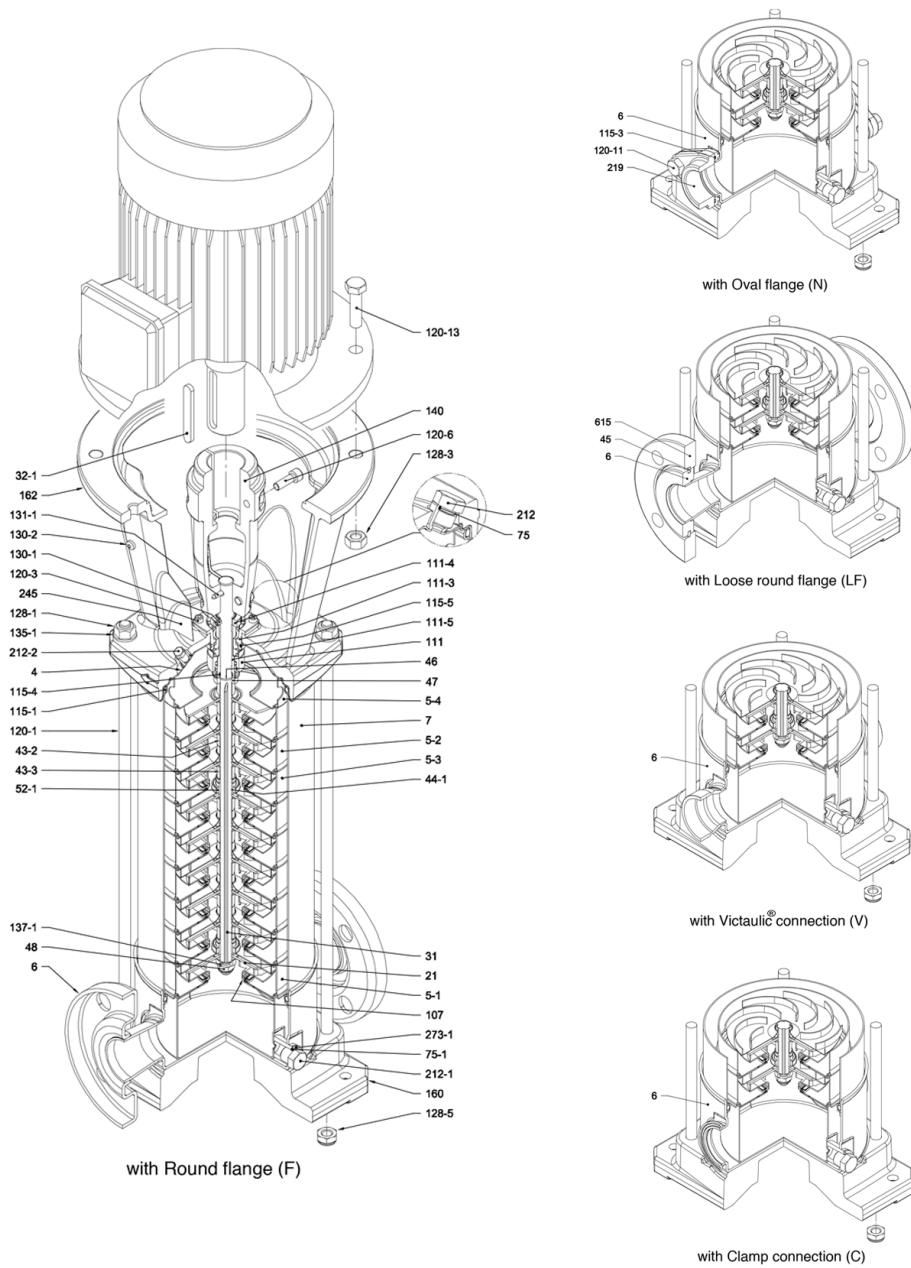

(2/4)

Construction

Pump name EVMS10 11N5Q1BEGE/4.0

Customer	Date 2022-04-19	Company
Contact	Item no.	Issued by
Phone	Project	Phone
E-mail	Project ID	E-mail

N°	PART NAME	MATERIAL		DIMENSIONS	STANDARD
		EVMS	EVMSL		
4	Casing cover	EN 1.4301 (AISI 304)	EN 1.4404 (AISI 316L)		
5-1	Suction casing	EN 1.4301 (AISI 304)	EN 1.4404 (AISI 316L)		
5-2	Intermediate casing	EN 1.4301 (AISI 304)	EN 1.4404 (AISI 316L)		
5-3	Intermediate casing with bearing	EN 1.4301 (AISI 304)	EN 1.4404 (AISI 316L)		
5-4	Discharge casing	EN 1.4301 (AISI 304)	EN 1.4404 (AISI 316L)		
6	Bottom casing	EN 1.4301 (AISI 304)	EN 1.4404 (AISI 316L)		
7	Outer casing	EN 1.4301 (AISI 304)	EN 1.4404 (AISI 316L)		
21	Impeller	EN 1.4301 (AISI 304)	EN 1.4404 (AISI 316L)		
31	Shaft	EN 1.4301 (AISI 304)	EN 1.4404 (AISI 316L)		
32-1	Adjuster key	EN 1.4301 (AISI 304)			
43-2	Shaft sleeve (intermediate)	EN 1.4301 (AISI 304)	EN 1.4404 (AISI 316L)		
43-3	Shaft sleeve (bearing+discharge casing)	EN 1.4301 (AISI 304)	EN 1.4404 (AISI 316L)		
44-1	Shaft sleeve bearing	Tungsten carbide			
45	Flange holder	EN 1.4301 (AISI 304)			
46	Ring (mechanical seal)	EN 1.4404 (AISI 316L)			
47	Ring holder	EN 1.4301 (AISI 304)	EN 1.4404 (AISI 316L)		
48	Impeller nut	EN 1.4301 (AISI 304) with inox insert	EN 1.4401 (AISI 316) with inox insert	M10	
52-1	Sleeve bearing	Tungsten carbide			
75	O-Ring (priming plug)	EPDM / FPM *		Ø12.37x2.62	OR 3050
75-1	O-Ring (drainage plug)	EPDM / FPM *			
107	Liner ring	EN 1.4301 (AISI 304) + PPS	EN 1.4404 (AISI 316L) + PPS		
111	Mechanical seal	- - - **			
111-3	Mechanical seal seat	EN 1.4301 (AISI 304)	EN 1.4401 (AISI 316)		
111-4	Seal holder	EN 1.4301 (AISI 304)			
111-5	Mechanical seal cartridge sleeve	EN 1.4301 (AISI 304)	EN 1.4404 (AISI 316L)		
115-1	O-Ring (outer casing)	EPDM / FPM *		Ø164.46x5.34	OR 6945
115-3	O-Ring	EPDM / FPM *			
115-4	O-Ring (cartridge sleeve)	EPDM / FPM *		Ø15.88x2.62	OR 4093
115-5	O-Ring (seal flange)	EPDM / FPM *		Ø37.77x2.62	OR 4175
120-1	Tie-rod	EN 1.4057 (AISI 431)		M12	
120-3	Screw (seal flange)	A2-70		M5x12	ISO 4762
120-6	Screw (pump coupling)	up to 4.0 kW from 5.5 kW to 7.5 kW above 11 kW	Galvanized steel	M6x25	ISO 4762
				M8x20	ISO 4762
				M10x30	ISO 4762
120-11	Screw (counterflange)	A2-70			
120-13	Screw for motor	MEC 80 MEC 90-100-112 MEC 132 MEC 160	Galvanized steel 8.8 strength class ISO 898/1	M6x20	ISO 4017
				M8x20	ISO 4017
				M12x40	UNI 5739
				M16x50	ISO 4017
128-1	Nut (tie rod)	A2-70		M12	ISO 4032
128-3	Nut (motor)	MEC 132 MEC 160	Galvanized steel	M12	ISO 4032
				M16	ISO 4032
128-5	Nut (tie rod)	A2-70		M12	UNI 7474
128-6	Nut (aluminium coupling)	MEC 71-80-90-100-112	Galvanized steel	M6	ISO 4032
130-1	Set screw	EN 1.4301 (AISI 304)		M5x8	ISO 4026
130-2	Screw for coupling guard	A2-70		M5x6	UNI 7687
131-1	Pin for shaft	Carbon Steel		Ø5x35	ISO 2338
135-1	Washer (tie rod)	EN 1.4301 (AISI 304)		Ø13x24x2.5	ISO 7089
135-6	Washer (aluminium coupling)	up to 4.0 kW	Carbon Steel	Ø6	
137-1	Impeller spacer	EN 1.4301 (AISI 304)	EN 1.4404 (AISI 316L)		
140	Coupling	up to 4.0 kW above 5.5 kW	Die cast Aluminium EN AB-AISI11 Cu2 (Fe)		
			Cast Iron		
160	Base	Die cast Aluminium EN AB-AISI11 Cu2 (Fe)			
162	Motor bracket	Cast iron EN-GJL-250			
212	Priming plug	EN 1.4301 (AISI 304)	EN 1.4404 (AISI 316L)	G 3/8	
212-1	Drainage plug	EN 1.4301 (AISI 304)	EN 1.4404 (AISI 316L)	G 3/8	
212-2	Venting plug	EN 1.4404 (AISI 316L)			
219	Counter flange	EN 1.4301 (AISI 304)	EN 1.4404 (AISI 316L)		
245	Coupling guard	EN 1.4301 (AISI 304)			
273-1	Washer (drainage plug)	EN 1.4301 (AISI 304)	EN 1.4404 (AISI 316L)		
615	Flange	Nodular Cast Iron			

* EPDM (standard)
FPM (option)

** see CONSTRUCTION 4/4

(3/4)

Construction

Pump name EVMS10 11N5Q1BEGE/4.0

Customer	Date	2022-04-19	Company
Contact	Item no.		Issued by
Phone	Project		Phone
E-mail	Project ID		E-mail

Pump Type	N°																																
	4	5-1	52	53	54	6	7	21	31	32-1	43-2	43-3	44-1	45**	46	47	48	52-1	75	75-1	107	111	111-3	111-4	111-5	115-1	115-3*	115-4	115-5	115-4	115-5	115-4	115-5
EVMS(L)10 2/0.75	1	1	/	1	1	1	1	2	1	1	/	2	1	4	2	1	1	1	1	2	2	1	1	1	1	2	2	1	1	1	1	1	1
EVMS(L)10 3/1.5	1	1	1	1	1	1	1	3	1	1	1	2	1	4	2	1	1	1	1	2	3	1	1	1	1	2	2	1	1	1	1	1	1
EVMS(L)10 4/2.2	1	1	2	1	1	1	1	4	1	1	2	2	1	4	2	1	1	1	1	2	4	1	1	1	1	2	2	1	1	1	1	1	1
EVMS(L)10 5/2.2	1	1	3	1	1	1	1	5	1	1	3	2	1	4	2	1	1	1	1	2	5	1	1	1	1	2	2	1	1	1	1	1	1
EVMS(L)10 6/2.2	1	1	4	1	1	1	1	6	1	1	4	2	1	4	2	1	1	1	1	2	6	1	1	1	1	2	2	1	1	1	1	1	1
EVMS(L)10 7/3.0	1	1	5	1	1	1	1	7	1	1	5	2	1	4	2	1	1	1	1	2	7	1	1	1	1	2	2	1	1	1	1	1	1
EVMS(L)10 8/3.0	1	1	6	1	1	1	1	8	1	1	6	2	1	4	2	1	1	1	1	2	8	1	1	1	1	2	2	1	1	1	1	1	1
EVMS(L)10 9/4.0	1	1	7	1	1	1	1	9	1	1	7	2	1	4	2	1	1	1	1	2	9	1	1	1	1	2	2	1	1	1	1	1	1
EVMS(L)10 10/4.0	1	1	8	1	1	1	1	10	1	1	8	2	1	4	2	1	1	1	1	2	10	1	1	1	1	2	2	1	1	1	1	1	1
EVMS(L)10 11/4.0	1	1	9	1	1	1	1	11	1	1	9	2	1	4	2	1	1	1	1	2	11	1	1	1	1	2	2	1	1	1	1	1	1
EVMS(L)10 12/5.5	1	1	9	2	1	1	1	12	1	1	9	3	2	4	2	1	1	2	1	2	12	1	1	1	1	2	2	1	1	1	1	1	1
EVMS(L)10 14/5.5	1	1	11	2	1	1	1	14	1	1	11	3	2	4	2	1	1	2	1	2	14	1	1	1	1	2	2	1	1	1	1	1	1
EVMS(L)10 15/5.5	1	1	12	2	1	1	1	15	1	1	12	3	2	4	2	1	1	2	1	2	15	1	1	1	1	2	2	1	1	1	1	1	1
EVMS(L)10 16/7.5	1	1	13	2	1	1	1	16	1	1	13	3	2	4	2	1	1	2	1	2	16	1	1	1	1	2	/	1	1	1	1	1	1
EVMS(L)10 18/7.5	1	1	15	2	1	1	1	18	1	1	15	3	2	4	2	1	1	2	1	2	18	1	1	1	1	2	/	1	1	1	1	1	1
EVMS(L)10 19/7.5	1	1	16	2	1	1	1	19	1	1	16	3	2	4	2	1	1	2	1	2	19	1	1	1	1	2	/	1	1	1	1	1	1
EVMS(L)10 21/7.5	1	1	18	2	1	1	1	21	1	1	18	3	2	4	2	1	1	2	1	2	21	1	1	1	1	2	/	1	1	1	1	1	1
EVMS(L)10 22/11	1	1	19	2	1	1	1	22	1	1	19	3	2	4	2	1	1	2	1	2	22	1	1	1	1	2	/	1	1	1	1	1	1
EVMS(L)10 23/11	1	1	19	3	1	1	1	23	1	1	19	4	3	4	2	1	1	3	1	2	23	1	1	1	1	2	/	1	1	1	1	1	1

Pump Type	N°																								
	120-1	120-3	120-6	120-11*	120-13	128-1	128-3	128-5	128-6	130-1	130-2	131-1	135-1	135-6	137-1	140	160	162	212	212-1	212-2	219*	245	273-1	615**
EVMS(L)10 2/0.75	4	4	4	4	4	4	/	4	4	3	4	1	4	4	1	2	1	1	1	2	1	2	2	2	2
EVMS(L)10 3/1.5	4	4	4	4	4	4	/	4	4	3	4	1	4	4	1	2	1	1	1	2	1	2	2	2	2
EVMS(L)10 4/2.2	4	4	4	4	4	4	/	4	4	3	4	1	4	4	1	2	1	1	1	2	1	2	2	2	2
EVMS(L)10 5/2.2	4	4	4	4	4	4	/	4	4	3	4	1	4	4	1	2	1	1	1	2	1	2	2	2	2
EVMS(L)10 6/2.2	4	4	4	4	4	4	/	4	4	3	4	1	4	4	1	2	1	1	1	2	1	2	2	2	2
EVMS(L)10 7/3.0	4	4	4	4	4	4	/	4	4	3	4	1	4	4	1	2	1	1	1	2	1	2	2	2	2
EVMS(L)10 8/3.0	4	4	4	4	4	4	/	4	4	3	4	1	4	4	1	2	1	1	1	2	1	2	2	2	2
EVMS(L)10 9/4.0	4	4	4	4	4	4	/	4	4	3	4	1	4	4	1	2	1	1	1	2	1	2	2	2	2
EVMS(L)10 10/4.0	4	4	4	4	4	4	/	4	4	3	4	1	4	4	1	2	1	1	1	2	1	2	2	2	2
EVMS(L)10 11/4.0	4	4	4	4	4	4	/	4	4	3	4	1	4	4	1	2	1	1	1	2	1	2	2	2	2
EVMS(L)10 12/5.5	4	4	4	4	4	4	/	4	4	3	4	1	4	/	1	2	1	1	1	2	1	2	2	2	2
EVMS(L)10 14/5.5	4	4	4	4	4	4	/	4	4	3	4	1	4	/	1	2	1	1	1	2	1	2	2	2	2
EVMS(L)10 15/5.5	4	4	4	4	4	4	/	4	4	3	4	1	4	/	1	2	1	1	1	2	1	2	2	2	2
EVMS(L)10 16/7.5	4	4	4	/	4	4	4	/	4	3	4	1	4	/	1	2	1	1	1	2	1	/	2	2	2
EVMS(L)10 18/7.5	4	4	4	/	4	4	4	/	4	3	4	1	4	/	1	2	1	1	1	2	1	/	2	2	2
EVMS(L)10 19/7.5	4	4	4	/	4	4	4	/	4	3	4	1	4	/	1	2	1	1	1	2	1	/	2	2	2
EVMS(L)10 21/7.5	4	4	4	/	4	4	4	/	4	3	4	1	4	/	1	2	1	1	1	2	1	/	2	2	2
EVMS(L)10 22/11	4	4	4	/	4	4	4	/	4	3	4	1	4	/	1	2	1	1	1	2	1	/	2	2	2
EVMS(L)10 23/11	4	4	4	/	4	4	4	/	4	3	4	1	4	/	1	2	1	1	1	2	1	/	2	2	2

* only for Oval flange (N)
 ** only for Loose round flange (LF)
 128-6 / 135-6: with Aluminium coupling

(4/4)

Construction

Pump name EVMS10 11N5Q1BEGE/4.0

Customer	Date 2022-04-19	Company
Contact	Item no.	Issued by
Phone	Project	Phone
E-mail	Project ID	E-mail



● : Standard

Pump model	Max operating temperature	Shaft seal type		Shaft seal material								Type key		
		Cartridge		1		2		3		4			5	
		Unbalanced	Balanced	Rotating Part	Code	Stationary Part	Code	Elastomers	Code	Compression spring	Collar		Code	
up to 16 bar	- 30°C to + 120°C	●		SiC	(Q1)	Carbon	(B)	EPDM	(E)	AISI 316		(G)	Q1BEG	

Max operating pressure	d1	d2	d3	d4	l
	[mm]	[mm]	[mm]	[mm]	[mm]
16 bar	20	-	29	35	37.5