

AQUABOOST

Framed Booster System

Offers variable speed pump technology to maintain constant pressure and flow when multiple outlets are operational.

The Aquaboost Framed Booster Set offers 200 litres of water and up to 80 litres per minute.



Features

- 1 year warranty
- Compact, space saving design
- Heads up to 65 m and flow rates up to 80 litres/min
- 200 litre cold water storage capacity
- Quiet operation
- CAT 3/4 fluid compatibility
- Variable speed pump control
- Easy installation
- Anti-vibration feet

Application

- Boosting cold mains water pressure and flow in larger domestic and small commercial applications

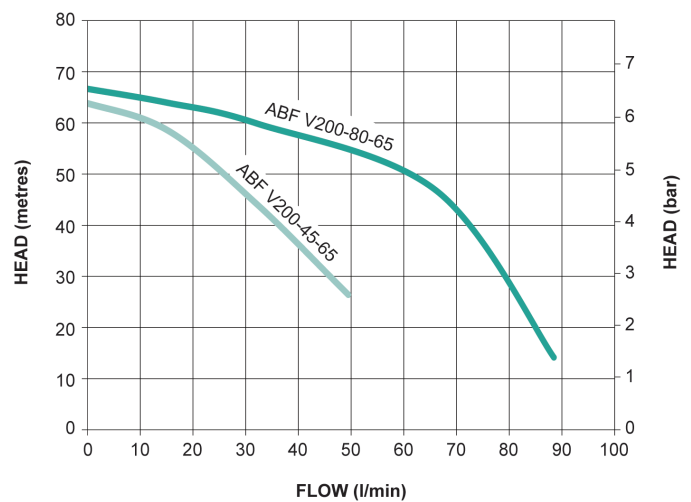

Pump Model		ABF V200-45-65 50 Hz 46690	ABF V200-80-65 50 Hz 46691
General	Warranty	1 year	
	WRAS approval	Approved materials	
	Approvals	UKCA, CE	
Features	Water tank air gap	Type AF / AG	
	Fluid risk compatibility	CAT 3 / CAT 4	
	Pump control system	Variable speed / pressure transducer	
	Pump control mode	Duty	
	Dry run protection	✓	✓
	Pressure vessel	18 litres	
	Anti-vibration feet	✓	✓
	Flexible connection hose - outlet	✓	✓
Noise	<70 dB(A)		
Performance	Maximum head (closed valve)	65 metres	
	Maximum flow	45 l/min	80 l/min
	Maximum static inlet pressure	5 bar	
	Maximum static outlet pressure	50 metres	
	Maximum working pressure*	1000 kPa (10 bar)	
	Ambient air temperature range	Min 4 °C / Max 30 °C	
Water tank	Nominal water tank size	270 litres	
	Usable water capacity	227 litres	
	Float valve type	Equilibrium	
Connections	Inlet connection	¾ "	
	Outlet connection	1 " BSP	
	Outlet flexible hose	1 " BSP	
	Overflow	1¼ "	
	Drain valve	½ "	
Materials	Water tank	Polyethylene	
Pump	Pump type	Centrifugal	
	Motor type	Induction (thermal trip / auto reset)	
	Duty rating	Continuous (S1)	
Electrical	Power supply / phase / frequency	230 V a.c. / 1 / 50 Hz	
	Current (full load)	6.8 Amps	
	Power consumption	1.1 kW	
	Fuse rating	10 Amp	
	Power cable (pre-wired)	2 metres	
Physical	Enclosure protection	IP55	
	Width	600 mm	
	Depth	600 mm	
	Height (excluding hoses)	1475 mm	
	Weight (including fittings)	110 Kg	115 Kg
	Weight (filled)	337 Kg	342 Kg

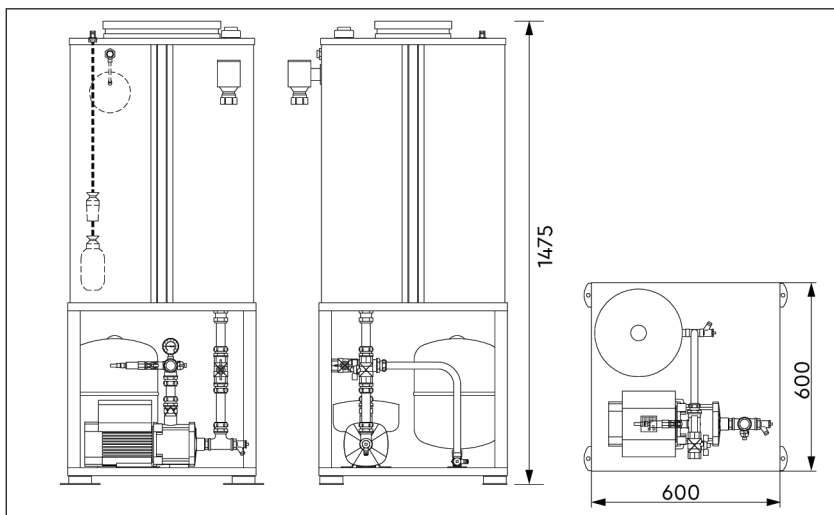

Stuart Turner Limited reserves the right to amend specifications without notice.