

# AQUABOOST

## Framed Booster CAT 5

Featuring a weir overflow making it suitable for use in commercial applications where the risk of back flow contamination from Category 5 fluids exists.

Aquaboost Framed Booster CAT 5 offers variable speed pump technology to maintain constant pressure and flow when multiple outlets are operational.

Available in tank sizes 50 – 100 litres and flow rates up to 80 litres per minute.



### Features

- 1 year warranty
- Compact, space saving design
- Heads up to 35 m and flow rates up to 80 litres/min
- 50 and 100 litre cold water storage capacity options
- Quiet operation
- CAT 5 fluid compatible
- Fixed speed pump control
- Easy installation
- Anti-vibration feet

### Application

- Boosting cold mains water pressure and flow in small commercial applications where exposure to fluid risk Category 5 exists

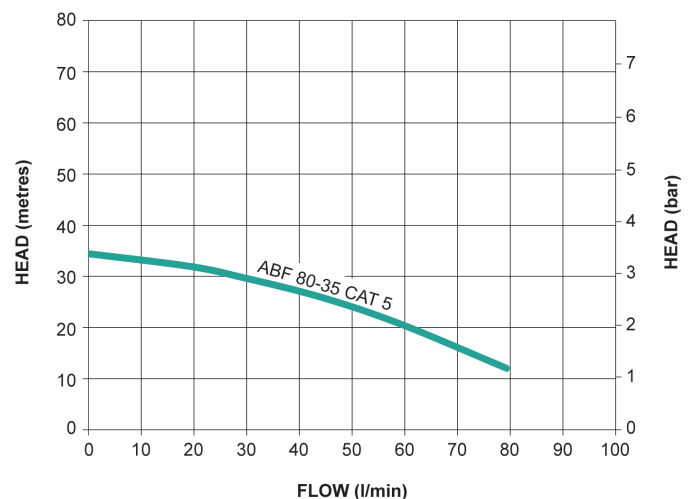

Pump Model		ABF F50-80-35 CAT 5 50 Hz 46692	ABF F100-80-35 CAT 5 50 Hz 46693
General	Warranty	1 year	
	WRAS approval	Approved materials	
	Approvals	UKCA, CE	
Features	Water tank air gap	Type AB + weir	
	Fluid risk compatibility	CAT 5	
	Pump control system	Fixed speed / pressure switch	
	Pump control mode	Duty	
	Dry run protection	✓	✓
	Anti-vibration feet	✓	✓
	Flexible connection hose – outlet	✓	✓
Noise	<70 dB(A)		
Performance	Maximum head (closed valve)	35 metres	
	Maximum flow	80 l/min	
	Maximum static inlet pressure	2.7 bar	
	Maximum static outlet pressure	15 metres	
	Maximum working pressure*	1000 kPa (10 bar)	
	Ambient air temperature range	Min 4 °C / Max 30 °C	
Water tank	Nominal water tank size	67 litres	113 litres
	Usable water capacity	55 litres	91 litres
	Float valve type	Low pressure BS1212 Part 2	
Connections	Inlet connection	½ "	
	Outlet connection	1 " BSP	
	Outlet flexible hose	1 " F BSP	
	Overflow	¾ " BSP	
	Drain valve	½ "	
Materials	Water tank	Polyethylene	
Pump	Pump type	Centrifugal	
	Motor type	Induction (thermal trip / auto reset)	
	Duty rating	Continuous (S1)	
Electrical	Power supply / phase / frequency	230 V a.c. / 1 / 50 Hz	
	Current (full load)	4.5 Amps	
	Power consumption	0.97 kW	
	Fuse rating	13 Amp	
	Power cable (pre-wired)	2 metres	
Physical	Enclosure protection	IP55	
	Width	618 mm	668 mm
	Depth	600 mm	614 mm
	Height (excluding hoses)	796 mm	896 mm
	Weight (including fittings)	60 Kg	70 Kg
	Weight (filled)	120 Kg	160 Kg

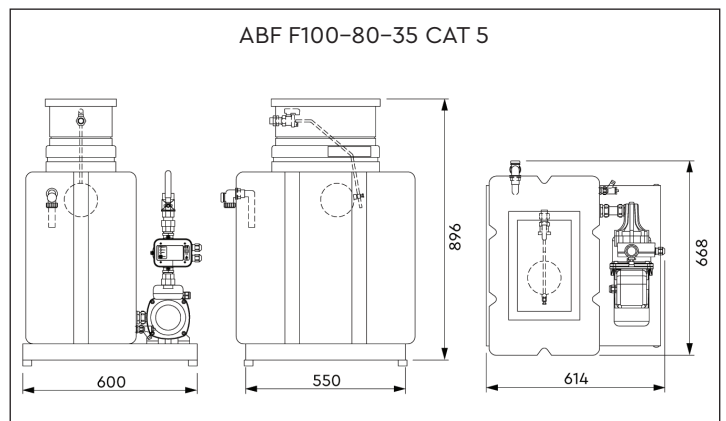
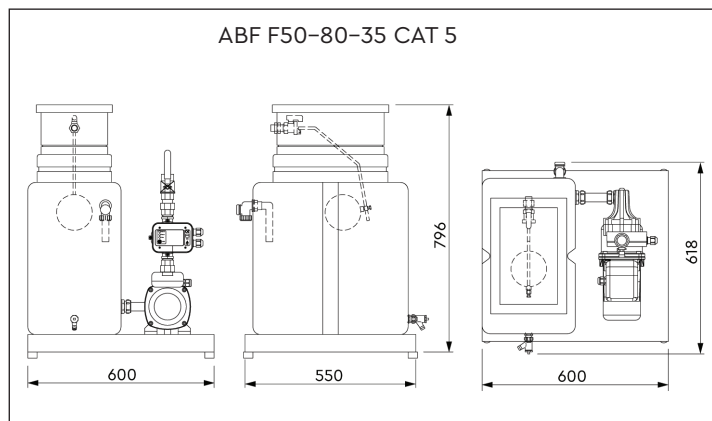

Stuart Turner Limited reserves the right to amend specifications without notice.