



## DOMESTIC FIXED SPEED-5HM06P-230V

| COMPONENT        | MATERIAL            |
|------------------|---------------------|
| PUMP BODY        | STAINLESS STEEL     |
| IMPELLER         | TECHNOPOLYMER NORYL |
| DIFFUSER         | STAINLESS STEEL     |
| SHAFT            | STAINLESS STEEL     |
| ADAPTER          | ALUMINIUM           |
| SEAL HOUSING     | STAINLESS STEEL     |
| FILL/DRAIN PLUGS | NICKEL-PLATED BRASS |
| WEAR RING        | TECHNOPOLYMER       |
| BOLTS AND SCREWS | STAINLESS STEEL     |



### TECHNICAL DATA

|           |        |                   |                  |
|-----------|--------|-------------------|------------------|
| VOLTAGE   | 230 V  | MAX PRESSURE      | 10 BAR           |
| FREQUENCY | 50 Hz  | MAX TEMPERATURE   | 40 °C            |
| POWER     | 1.1 kW | PROTECTION RATING | IP55             |
| FLC       | 6.88 A | PART CODE         | 5050-5HM06P-FS/1 |

### DIMENSIONS

| A   | B   | INLET/OUTPUT |
|-----|-----|--------------|
| 620 | 610 | DN32 FBSP    |

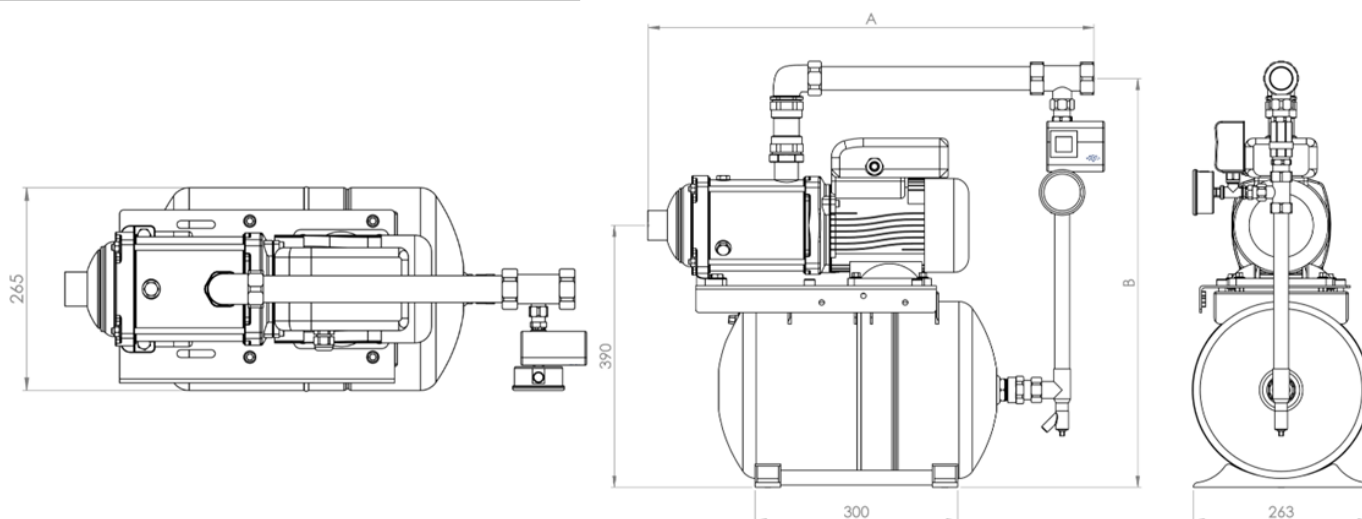



## PERFORMANCE CURVE

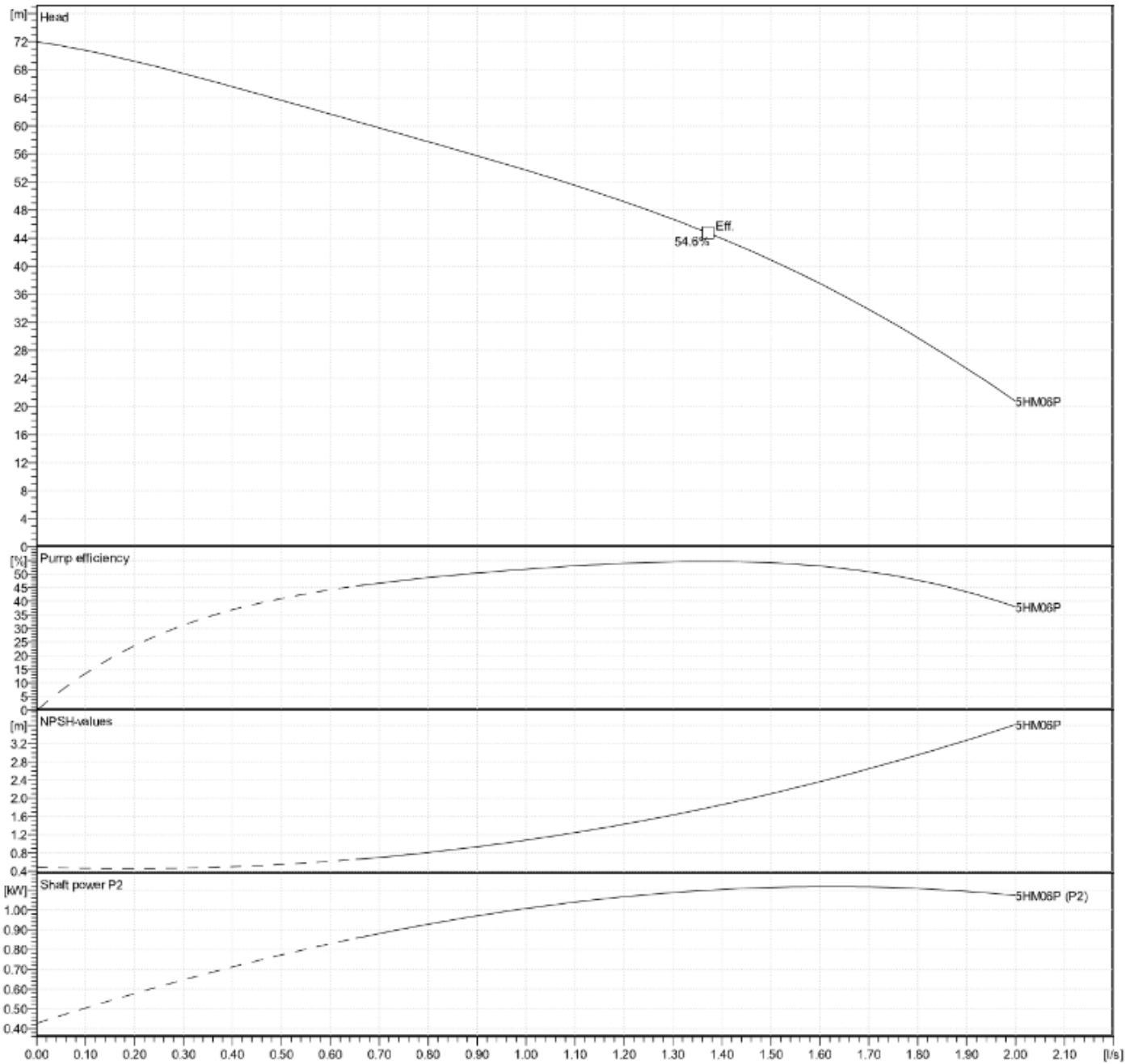

**SPECIALITIES** Pumps • Booster Sets • Pressurisation • Heating • Cold Water • Heat Exchangers • Service / Repair • Pressure Vessels • Pump Accessories

**GM Treble Ltd**  
New Street, Parkfields,  
Wolverhampton. WV4 6AN

Tel: +44 (0)1902 333 111  
Fax: +44(0)1902 340 941

[www.gmtreble.co.uk](http://www.gmtreble.co.uk)  
Email: [sales@gmtreble.co.uk](mailto:sales@gmtreble.co.uk)