

Chantrelle®

PUMP



2" ELECTRIC WATER PUMP

MODEL NO: ECP20A1

PART NO: 7120405

OPERATION & MAINTENANCE INSTRUCTIONS



ORIGINAL INSTRUCTIONS

GC1020 - rev 3

INTRODUCTION

Thank you for purchasing this Clarke Water Pump.

This non-submersible centrifugal pump is ideal for a range of domestic and light agricultural purposes.

It is designed to pump clean water in gardens for spraying and irrigation and for pumping water to greenhouses. It can also be used for boosting running water feed pressure (not drinking water) and for pumping out wells and ponds. It is not designed for use with contaminated or salt water. If used for pumping water from a pond, extra filtering measures should be taken to isolate any larger particles.

Before attempting to use this product, please read this manual thoroughly and follow the instructions carefully. In doing so you will ensure the safety of yourself and that of others around you, and you can look forward to your purchase giving you long and satisfactory service.



WARNING: THIS SYMBOL IS USED THROUGHOUT THE USER GUIDE WHENEVER THERE IS A RISK OF PERSONAL INJURY. ENSURE THAT THESE WARNINGS ARE READ AND UNDERSTOOD AT ALL TIMES.

Your CLARKE water pump has been designed to give long and trouble free service. If, however, having followed the instructions in this booklet carefully, you encounter problems, take the unit to your local Clarke dealer.

Please keep these instructions in a safe place for future reference.

GUARANTEE

This product is guaranteed against faulty manufacture for a period of 12 months from the date of purchase. Please keep your receipt which will be required as proof of purchase.

This guarantee is invalid if the product is found to have been abused or tampered with in any way, or not used for the purpose for which it was intended.

Faulty goods should be returned to their place of purchase, no product can be returned to us without prior permission.

This guarantee does not effect your statutory rights.

GENERAL SAFETY PRECAUTIONS

Before using this equipment it is in your own interest to read and pay attention to the following safety rules.



WARNING: ALWAYS CONNECT THE PUMP TO AN EARTHED POWER SUPPLY VIA AN RCD.

1. **NEVER** use for pumping flammable liquids or corrosive chemicals. This pump is designed to pump clean water only.
 2. **ALWAYS** keep the working area clean and well lit. Floors should always be kept clear. Cluttered or dark areas invite accidents.
 3. **NEVER** over-reach. Keep your proper footing and balance at all times when installing or maintaining the pump.
 4. **NEVER** direct any water discharge towards electrical wiring or equipment.
 5. **ALWAYS** thoroughly familiarise yourself with this pump & its operation, and follow all instructions in this manual. Never allow persons unfamiliar with these instructions to instal or operate the pump.
 6. **ALWAYS** ensure that the pump is properly installed to prevent it from moving during operation, and that the immediate area surrounding the pump is kept clear.
 7. **ALWAYS** maintain the pump with care and keep it clean for best / safest performance.
 8. **NEVER** use this product if any part is damaged. Have it inspected and repaired by your local Clarke dealer. Always turn the pump off before carrying out any maintenance.
 9. **NEVER** modify this pump in any way. Use it ONLY for the purpose for which it is designed.
 10. **ALWAYS** have the pump serviced by your local Clarke dealer, using only identical replacement parts. This will ensure the safety of the pump is maintained. The use of non standard parts could be hazardous.
 11. **NEVER** allow the pump to run dry.
-



CAUTION: THIS PUMP IS NOT A SUBMERSIBLE PUMP. ON NO ACCOUNT SHOULD IT EVER BE IMMERSIED IN WATER.

INSTALLATION

Because of the number of possible installations, no accessories are supplied with your pump except for a pair of male inlet/outlet adaptors. However accessories are available from your nearest Clarke dealer. See the suggested list on page 13.

NOTE: It is recommended that the end user should consult a qualified installer if there are any doubts as to the suitability of this product for a particular installation.

IMPORTANT: The pump MUST NOT be connected to the mains power supply until all hose/pipe installation is completed.

INSTALLATION OF THE PUMP

The pump must always be installed and operated in a horizontal position i.e. with the outlet port facing vertically upwards. The fixing holes in the base should be used to secure the pump firmly in it's operating position. Mount the pump on raised blocks or a purpose built platform to protect it from flooding. Some kind of anti-vibration mounting is also desirable.

Always ensure there is adequate air circulation around the motor. The pump should be installed in a dry, well ventilated enclosure, sheltered from rain.

ELECTRICAL INSTALLATION

The pump should be located at such a distance away from any pond or pool, as to avoid the possibility of immersion and the power supply should also be a safe distance away. If in doubt, please contact your electrical specialist and refer to national regulations.

Avoid situations where the pump could become drenched with water as neither the motor or terminal box are designed to be totally waterproof. Ensure the pump & its power cable do not create a safety hazard for people walking past it.

Before switching the product on, make sure that the voltage of your electricity supply is the same as that indicated on the rating plate. This product is designed to operate on 230VAC 50Hz. Connecting it to any other power source may cause damage.

ELECTRICAL CONNECTIONS



WARNING! READ THESE ELECTRICAL SAFETY INSTRUCTIONS THOROUGHLY BEFORE CONNECTING THE PRODUCT TO THE MAINS SUPPLY.

Before switching the product on, make sure that the voltage of your electricity supply is the same as that indicated on the rating plate. This product is designed to operate on 230VAC 50Hz. Connecting it to any other power source may cause damage.

This product may be fitted with a non-rewireable plug. If it is necessary to change the fuse in the plug, the fuse cover must be refitted. If the fuse cover becomes lost or damaged, the plug must not be used until a suitable replacement is obtained.

If the plug has to be changed because it is not suitable for your socket, or due to damage, it should be cut off and a replacement fitted, following the wiring instructions shown below. The old plug must be disposed of safely, as insertion into a mains socket could cause an electrical hazard



**WARNING! THE WIRES IN THE POWER CABLE SHOULD BE COLOURED IN ACCORDANCE WITH THE FOLLOWING CODE:
(Blue = Neutral Brown = Live Yellow and Green = Earth**

To ensure that the colours of the wires in the power cable correspond with the markings on the terminals of your plug, proceed as follows.

- The wire which is coloured **Blue** must be connected to the terminal which is marked **N** or coloured **Black**.
- The wire which is coloured **Brown** must be connected to the terminal which is marked **L** or coloured **Red**.
- The wire which is coloured **Yellow and Green** must be connected to the terminal which is marked **E** or \perp or coloured **Green**

Plug must be BS1363/A approved.

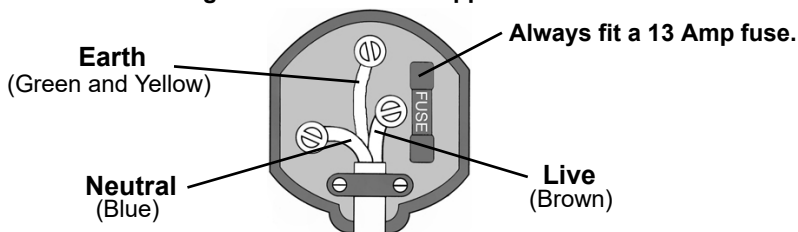

Ensure that the outer sheath of the cable is firmly held by the clamp

We strongly recommend that this machine is connected to the mains supply via a Residual Current Device (RCD)

If in any doubt, consult a qualified electrician. DO NOT attempt any connections yourself.

PIPE/HOSE CONNECTIONS

The pump inlet and discharge ports are both 2" BSP (51 mm) female threads and accept the adaptors supplied.

Hoses with the same diameter should be used and secured to the adaptor with a suitable hose clip.

Ensure all connections are air tight when under pressure but not so tight as to crack the plastic inlet/outlet adaptors.

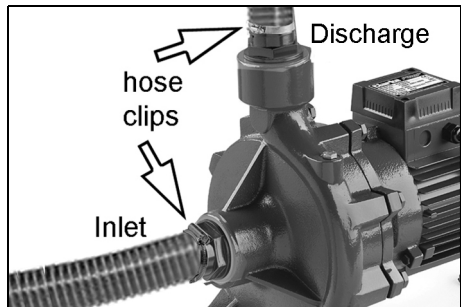

ADDITIONAL CONSIDERATIONS

- Strain caused by vibration can be reduced by connecting a short flexible hose between any rigid pipework and the pump.
- We recommend that you always use pipes/hoses with a minimum diameter of 2" (51 mm).
- Any restriction in the pipeline will greatly reduce the flow.
- Ensure that the hoses and pipes are supported along their entire length. They will be considerably heavier when filled with water.
- We recommend that you install isolation valves either side of the pump in order to isolate the pump during maintenance/removal.
- A gate valve may be installed in-line on the delivery side of the pump which can be adjusted as required to regulate the flow of water and can assist in priming the pump.
- If there is any chance of freezing, protect the pump and pipework with suitable lagging. The formation of ice may cause serious damage.

SUCTION LIFT OR GRAVITY FEED

There are two possible methods of pipework installation.

1. **Suction Lift.** Used to draw clean water from a pool or well providing the vertical distance between the foot valve and the pump does not exceed the 8 metres specified for this pump.

It is essential that all connections and hoses are airtight or the system will not work effectively.

A foot valve/filter fitted to the lower end of the suction hose, (as illustrated), is essential to retain water in the system as the pump is not self priming.

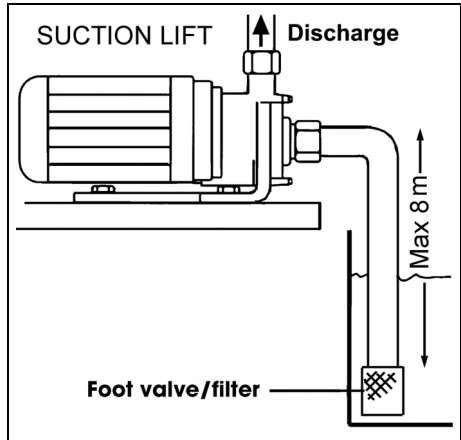

2. **Gravity Feed.** Used to draw water from a tank above ground.

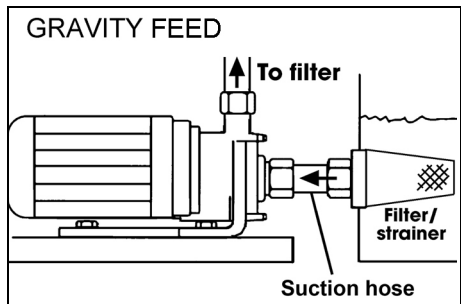

PRIMING THE PUMP

Before using the pump for the first time the inlet (suction) side must be filled with water to prime the pump as follows:-

1. With all inlet pipes/hoses, but no outlet hose connected, pour water into the outlet port until all the air is expelled.
2. Connect the outlet hose to the outlet port.

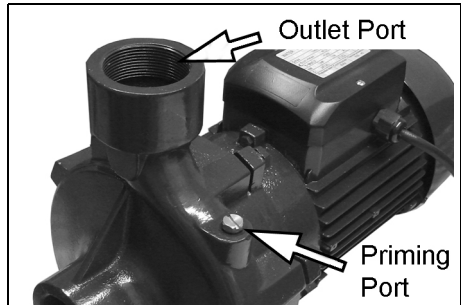

If the outlet hose is already connected, a priming port and threaded plug are provided, adjacent to the outlet as shown.

NOTE: As the priming hole is quite small, it is necessary to fill the inlet (suction) pipe with water before connecting to the pump, and top up through the priming port once the pipe is connected. A non-return valve will need to be fitted to the inlet pipe for this purpose.

3. Switch on the pump.
 - Water should start to flow through the system.
4. Check for leaks and correct if necessary.
5. Adjust any device such as a non-return valve, which may be fitted to the outlet side of the pump, to maximise efficiency.
 - Do not place any restriction on the inlet or discharge hoses.

Remember - this pump is designed for pumping CLEAN WATER ONLY. DO NOT USE for pumping chemicals or other flammable or corrosive liquids.

OPERATION

1. Open any valves in the pipeline.
2. If operating the pump for the first time, prime the pump as described. on page 8.

NOTE: Refilling (re-priming) is only necessary if the pump has been drained.

3. Connect to the power supply and switch on.
 - When water starts to flow through the system check for leaks and correct if necessary.
 - If the motor fails to start or the pump does not deliver water, refer to TROUBLESHOOTING.
 - Never operate the pump when not primed with water or if the inlet is blocked which would allow the pump to run dry, causing damage.

NOTE: Filling the suction pipe with water will speed up the priming process, and it is important that a non-return valve be fitted to the end of the suction pipe.

4. Stop the pump by switching off the power supply.

CARE DURING USE

1. Do not allow the pump to run dry, otherwise the seal between the pump and motor may be damaged. If a leak occurs at this point, allowing water to pass from the pump to the motor, take the pump to your Clarke dealer for overhaul.
2. In the event of a blockage, where debris has entered the pump, it can be cleaned out as described under MAINTENANCE.
3. DO NOT USE for pumping chemicals or other corrosive liquids. Should contaminants enter the pump, flush through with water as soon as possible to prevent damage.
4. If the pump is being used to drain a pool, ensure there is adequate drainage and there is no risk of damage to property as a result of water being discharged. If a flexible hose must be laid across a roadway, protect it with wooden planking.

MAINTENANCE

Inspect the pump/hoses regularly to ensure that debris is not blocking the passage of water.

If you suspect the pump is blocked by silt, leaf debris etc, disconnect it from the power supply, disconnect the discharge hose and back-flush to clear any blockage using a hosepipe.

Always keep the pump in a clean condition and check regularly for damage to the power cable etc.

AFTER USE

After use, and if the pump will not be used over the winter period, or if there is danger of freezing, always drain the pump body.

If the pump has been used with contaminated or salty water, it should be thoroughly flushed with clean water following use, both inside and out. It should then be drained and covered over, if not already sheltered from the weather.

If the pump is seized following a period of inactivity, it may be possible to free it off. Ensure the pump power supply is turned off before by inserting a screwdriver into either the infeed or discharge port and dislodging a jammed impeller. If this is not successful it may be necessary to remove the relevant mounting bolts to separate the pump body and clean away any incrustation.

Re-prime the pump when returning to service.

In the event that overhaul of the pump or motor is necessary, contact your Clarke service department.

ENVIRONMENTAL RECYCLING POLICY



Through purchase of this product, the customer is taking on the obligation to deal with the WEEE in accordance with the WEEE regulations in relation to the treatment, recycling & recovery and environmentally sound disposal of the WEEE.

In effect, this means that this product must not be disposed of with general household waste. It must be disposed of according to the laws governing Waste Electrical and Electronic Equipment (WEEE) at a recognised disposal facility.

TROUBLESHOOTING

Problem	Cause	Solution
Pump does not run.	Thermal protection has been activated.	If the motor has overheated, wait for it to cool down before trying again.
	Faulty power connection	Insert plug securely.
	No mains supply	Check fused power supply and replace fuse if necessary (check fuse rating). Check circuit breaker
	Impeller seized/blocked	Disconnect pump from power supply. Investigate cause and clear blockage
Pump fails to prime	Air leaks through suction hose joints (damaged hose, broken clamp, damaged).	Repair connections/ replace hose as necessary.
	Blocked inlet hose	Check pipeline for blockage. Check any inlet valve fitted is fully open.
Pump runs but gives poor output	Congested material inside pump	Clean out & backflush pump.
	Suction or delivery line obstructed.	Remove obstruction and ensure there are no kinks in delivery line.
	Inlet pipe leakage.	Check inlet pipe and connector for leaks. Tighten as required.
	Air leaks through damaged seal.	Renew seal.
	Impeller damaged and making poor seal.	Return to your Clarke dealer for repair
	Impeller / mechanical seal is badly worn.	Return to your Clarke dealer for repair.

	High friction losses in the suction line.	Avoid unnecessary curves, restrictions or valves
	Pump badly sited resulting in suction lift too high	Set pump as close as possible to the level of the water to be pumped
Sudden loss of flow.	Blockage of inlet pipe	Check pipeline for blockage.
Undue vibration or noise.	Excessive flow of water.	Decrease flow of water. by adjusting inlet/outlet valves in system.
	Resistance in inlet pipe caused by obstruction.	Check pipe and clean out as necessary
	Loose rotating component	Return to your dealer for repairs.
	Installation of pump is unstable.	Stop pump and re-position.
	Air pocket in pump or pipeline.	Release plug in impeller housing to release air.
	Damaged impeller	Return to your Clarke dealer for repair.

SPECIFICATION

Model	ECP20A1
Water Classification	Clean
Maximum Delivery	400 l/min (23.9m ³ /hr)
Rated Head	4-20 m
Maximum Suction Lift	8 m
Operating Temperature	0-40°C
Ingress Protection Rating	IP x4 (splashing water)
Duty Cycle	S1 Continuous
Supply	230V / 50Hz / 1ph
Rated Input Power	1700 W
Outlet Thread Size	2" BSP
Weight	28.2 kg
Length x Width x Height	450 x 242 x 325 mm
Sound Pressure Level	63.0 dB LpA
Sound Power Level	71.0 dB LwA

ACCESSORIES

2" BSP Plastic Foot Valve Filter FVF20	Part No:7950684
2" dia Reinforced Suction/Delivery Hose	Part No:7955020
2" dia Layflat Delivery Hose 10M	Part No:7955160
2" BSP Female Coupling	Part No:7950320
2" BSP Male Coupling	Part No:7950220
2" Hose Adaptor 90° Bend	Part No:7950205

ECP20A1 PARTS DIAGRAM

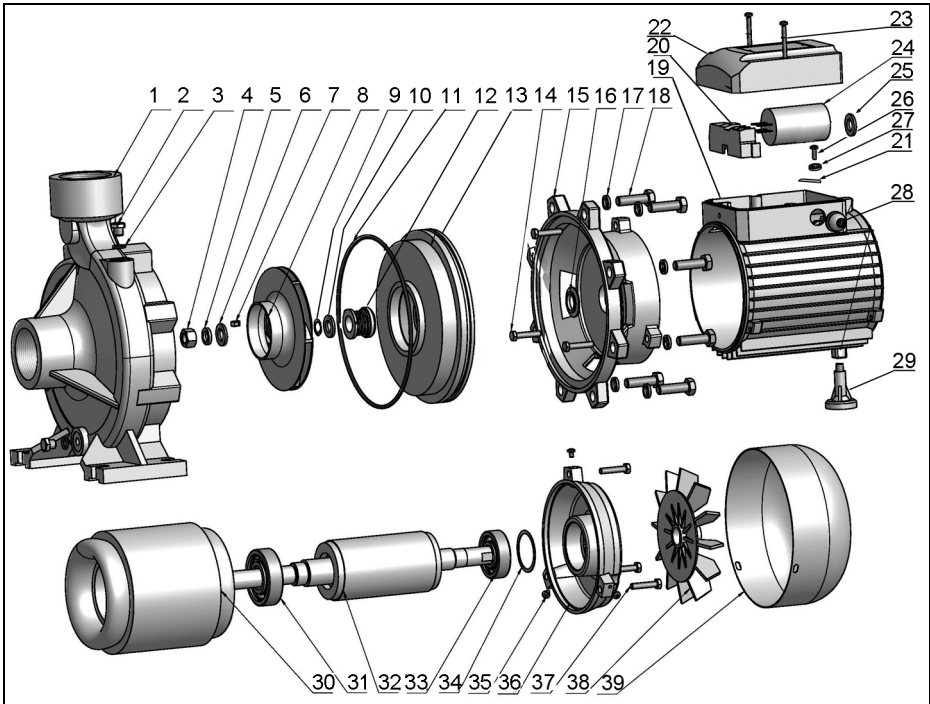

ID	DESCRIPTION	ID	DESCRIPTION	ID	DESCRIPTION
1	Pump Casing	14	Bolt	27	Locking Washer
2	Discharge Plug	15	Pump Support	28	Fairlead
3	O-Ring	16	Drops Guard	29	Stand
4	Nut	17	Spring Washer	30	Stator Winding
5	Snap Ring	18	Bolt	31	Bearing
6	Washer	19	Motor Housing	32	Rotor
7	Key	20	Terminal Board	33	Bearing
8	Impeller	21	Grounding Mark	34	Circlip
9	Circlip	22	Terminal Box Cover	35	Screw
10	Washer	23	Screw	36	Back Cover
11	O-ring	24	Capacitor	37	Bolt
12	Mechanical Seal	25	O-ring	38	Fan
13	Seal Holding Disc	26	Screw	39	Fan Cover

DECLARATION OF CONFORMITY



DECLARATION OF CONFORMITY

This is an important document and should be retained.

We hereby declare that this product(s) complies with the following directive(s):

- 2006/42/EC Machinery Directive.
- 2014/30/EU Electromagnetic Compatibility Directive.
- 2014/35/EU Low Voltage Equipment Directive.
- 2011/65/EU Restriction of Hazardous Substances (amended by EU 2015/863).
- 2000/14/EC Noise Emissions Directive, (amended by 2005/88/EC).

The following standards have been applied to the product(s):

- EN ISO 12100:2010, EN 808-1:898+A1:2009+AC:2010, EN 60294-1:2006+A1:2009+AC:2010,
- EN 60335-1:2012+A11:2014+AC:2014, EN 60335-2-41:2003+A1:2004+AC:2010, EN 55014-1:2017,
- EN 62233:2008+AC:2008, EN 55014-2:2015, EN 61000-3-2:2014, EN 61000-3-3:2013.

The technical documentation required to demonstrate that the product(s) meet(s) the requirement(s) of the aforementioned directive(s) has been compiled and is available for inspection by the relevant enforcement authorities.

The CE mark was first applied in: 2016

Signed:

J.A. Clarke
Director

(15-0443)Centrifugal Water Pump D.O.C (r1) (N2020-0188)

Page 2 of 2



DECLARATION OF CONFORMITY

This is an important document and should be retained.

Product Description: Electric centrifugal 2" water pump, 1ph

Model number(s): ECP20A1

Serial / batch Number: 7120405

Date of issue: 16/10/2020

(/Noise Conformity)

Notified Body: n/a

Technical Documentation Holder:

A.R. Pond

Clarke International

2a Strubland Road

London E10 7RB

UK

Conformity Assessment Procedure: to 2000/14/EC Annex VI

Manufacturer: Clarke International

Noise Released Value: 2.2 kW

Measured Sound Power Level: 63 dB

Guaranteed Sound Power Level: 71 dB

(15-0443)Centrifugal Water Pump D.O.C (r1) (N2020-0188)

Page 1 of 2

A SELECTION FROM THE VAST RANGE OF

Clarke®

QUALITY PRODUCTS



AIR COMPRESSORS

From DIY to industrial, Plus air tools, spray guns and accessories.

GENERATORS

Prime duty or emergency standby for business, home and leisure.

POWER WASHERS

Hot and cold, electric and engine driven - we have what you need

WELDERS

Mig, Arc, Tig and Spot.
From DIY to auto/industrial.

METALWORKING

Drills, grinders and saws for DIY and professional use.

WOODWORKING

Saws, sanders, lathes, mortisers and dust extraction.

HYDRAULICS

Cranes, body repair kits, transmission jacks for all types of workshop use.

WATER PUMPS

Submersible, electric and engine driven for DIY, agriculture and industry.

POWER TOOLS

Angle grinders, cordless drill sets, saws and sanders.

STARTERS/CHARGERS

All sizes for car and commercial use.



PARTS & SERVICE: 0208 988 7400

Parts Enquiries
Parts@clarkeinternational.com

Servicing & Technical Enquiries
Service@clarkeinternational.com

SALES: UK 01992 565333 or Export 00 44 (0)1992 565335

Clarke INTERNATIONAL Hemnall Street, Epping, Essex CM16 4LG
www.clarkeinternational.com