

ChamPro®

PUMP

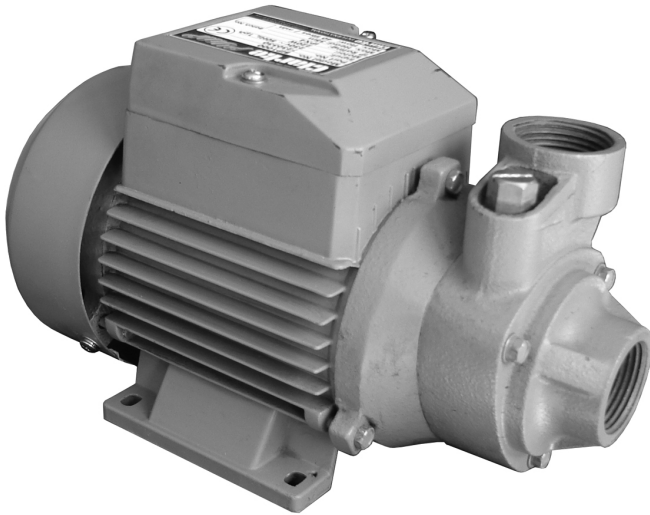

1" ELECTRIC WATER PUMP

MODEL NO: BIP1000

PART NO: 7230330

OPERATION & MAINTENANCE INSTRUCTIONS

CE

ORIGINAL INSTRUCTIONS

GC1020 - REV 4

INTRODUCTION

Thank you for purchasing this Clarke Water Pump.

Before attempting to use this product, please read this manual thoroughly and follow the instructions carefully. In doing so you will ensure the safety of yourself and that of others around you, and you can look forward to your purchase giving you long and satisfactory service.

DESCRIPTION

This non-submersible centrifugal pump is designed to pump clean water in gardens for spraying and irrigation purposes and for pumping water to greenhouses. It can also be used for boosting running water feed pressure (not drinking water) or for pumping out wells or ponds. Operating with contaminated or salt water should be avoided.



WARNING: THIS SYMBOL IS USED THROUGHOUT THE USER GUIDE WHENEVER THERE IS A RISK OF PERSONAL INJURY. ENSURE THAT THESE WARNINGS ARE READ AND UNDERSTOOD AT ALL TIMES.

Your CLARKE water pump has been designed to give long and trouble free service. If, however, having followed the instructions in this booklet carefully, you encounter problems, take the unit to your local Clarke dealer.

Please keep these instructions in a safe place for future reference.

GUARANTEE

This product is guaranteed against faulty manufacture for a period of 12 months from the date of purchase. Please keep your receipt which will be required as proof of purchase.

This guarantee is invalid if the product is found to have been abused or tampered with in any way, or not used for the purpose for which it was intended.

Faulty goods should be returned to their place of purchase, no product can be returned to us without prior permission.

This guarantee does not effect your statutory rights.

GENERAL SAFETY PRECAUTIONS

Before using this equipment it is in your own interest to read and pay attention to the following safety rules.



WARNING: ALWAYS CONNECT THE PUMP TO AN EARTHED POWER SUPPLY VIA AN RCD.

1. **ALWAYS** keep the working area clean and well lit. Floors should always be kept clear. Cluttered or dark areas invite accidents.
 2. **NEVER** over-reach. Keep your proper footing and balance at all times when installing or maintaining the pump.
 3. **NEVER** direct any water discharge towards electrical wiring or equipment.
 4. **ALWAYS** thoroughly familiarise yourself with this pump & its operation, and follow all instructions in this manual. Never allow persons unfamiliar with these instructions to instal or operate the pump.
 5. **ALWAYS** ensure that the pump is properly installed to prevent it from moving during operation, and that the immediate area surrounding the pump is kept clear.
 6. **ALWAYS** maintain the pump with care and keep it clean for best / safest performance.
 7. **NEVER** use this product if any part is damaged. Have it inspected and repaired by your local Clarke dealer. Always turn the pump off before carrying out any maintenance.
 8. **NEVER** modify this pump in any way. Use it **ONLY** for the purpose for which it is designed.
 9. **NEVER** use for pumping flammable liquids or corrosive chemicals. This pump is designed to pump clean water only.
 11. **ALWAYS** have the pump serviced by your local Clarke dealer, using only identical replacement parts. This will ensure the safety of the pump is maintained. The use of non standard parts could be hazardous.
 12. **NEVER** allow the pump to run dry.
-



CAUTION: THIS PUMP IS NOT A SUBMERSIBLE PUMP. ON NO ACCOUNT SHOULD IT EVER BE IMMERSSED IN WATER.

INSTALLATION

Because of the number of possible installations, no accessories are supplied with your pump, however accessories are available from your nearest Clarke dealer. See the suggested list on page 13.

NOTE: It is recommended that the end user should consult a qualified installer if there are any doubts as to the suitability of this product for a particular installation.

IMPORTANT: The pump MUST NOT be connected to the mains power supply until all hose/pipe installation is completed.

INSTALLATION OF THE PUMP

The pump must always be installed and operated in a horizontal position i.e. with the outlet port facing vertically upwards. The fixing holes in the base should be used to secure the pump firmly in it's operating position. Mount the pump on raised blocks or a purpose built platform to protect it from flooding. Some kind of anti-vibration mounting is also desirable.

Always ensure there is adequate air circulation around the motor. The pump should be installed in a dry, well ventilated enclosure, sheltered from rain.

ELECTRICAL INSTALLATION

The pump should be located at such a distance away from any pond or pool, as to avoid the possibility of immersion and the power supply should also be a safe distance away. If in doubt, please contact your electrical specialist and refer to national regulations.

Avoid situations where the pump could become drenched with water as neither the motor or terminal box are designed to be totally waterproof. Ensure the pump & its power cable do not create a safety hazard for people walking past it.

ELECTRICAL CONNECTIONS



WARNING! READ THESE ELECTRICAL SAFETY INSTRUCTIONS THOROUGHLY BEFORE CONNECTING THE PRODUCT TO THE MAINS SUPPLY.

The BIP1000 pump will need to be fitted with a 1.5m length of 1.5mm² flexible cable and a BS1363 approved plug. The plug will require connection to the cable in accordance with the diagram below.

FITTING THE CABLE

Do not attempt electrical installation work if you are in any doubt as to how it should be done correctly. Consult a qualified electrician.

The pump must be wired according to the diagram, after removing the cover plate, ensuring the following principles are observed:

- The cable used must be the correct size to ensure it is a tight fit in the cable gland.
- Ensure the cable gland is correctly used. The clamp must firmly hold the outer cable sheath and not the wires.
- Ensure the earth wire is correctly connected to the earth terminal.
- The bare earth wire should be wrapped around the body of the screw, positioned between the two washers and the screw suitably tightened.

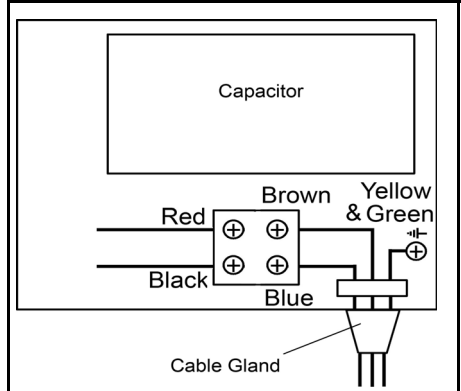
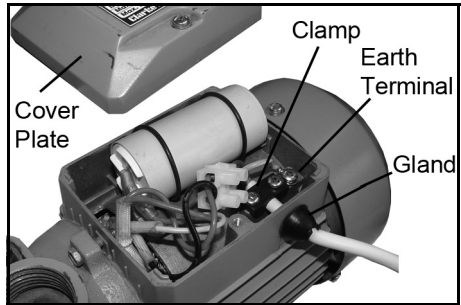

FITTING THE PLUG



**WARNING! THE WIRES IN THE POWER CABLE SHOULD BE COLOURED IN ACCORDANCE WITH THE FOLLOWING CODE:
(Blue = Neutral Brown = Live Yellow and Green = Earth**

To ensure that the colours of the wires in the power cable correspond with the markings on the terminals of your plug, proceed as follows.

- The wire which is coloured **Blue** must be connected to the terminal which is marked **N** or coloured **Black**.
- The wire which is coloured **Brown** must be connected to the terminal which is marked **L** or coloured **Red**.
- The wire which is coloured **Yellow and Green** must be connected to the terminal which is marked **E** or  or coloured **Green**

Plug must be BS1363/A approved.

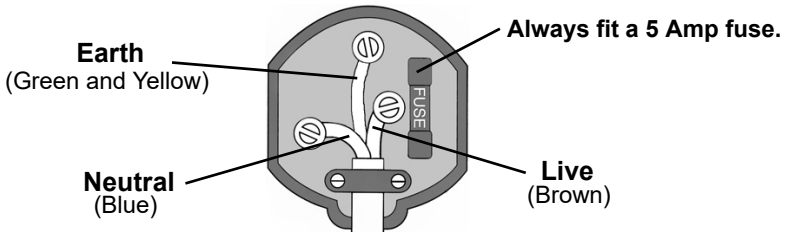

Ensure that the outer sheath of the cable is firmly held by the clamp

- Before switching the product on, make sure that the voltage of your electricity supply is the same as that indicated on the rating plate. This product is designed to operate on 230VAC 50Hz. Connecting it to any other power source may cause damage.

We strongly recommend that this machine is connected to the mains supply via a Residual Current Device (RCD))

If in any doubt, consult a qualified electrician. DO NOT attempt any connections yourself.

PIPE/HOSE CONNECTIONS

The pump inlet can be connected to any water source depending upon the installation layout, and the discharge outlet should be directed as required.

The diameter of the inlet/outlet connectors is 1" BSP (25.4 mm). Therefore hoses with the same diameter should be used and secured with a suitable 1" hose adaptor. Ensure all connections are air tight. Tighten them enough to secure the hose during pressurised operation, but not so tight as to crack any plastic inlet/outlet adaptors.

If the pump is going to be a permanent fixture, vibration and strain on adjacent parts can be reduced by connecting a short flexible hose between any rigid pipework and the pump.

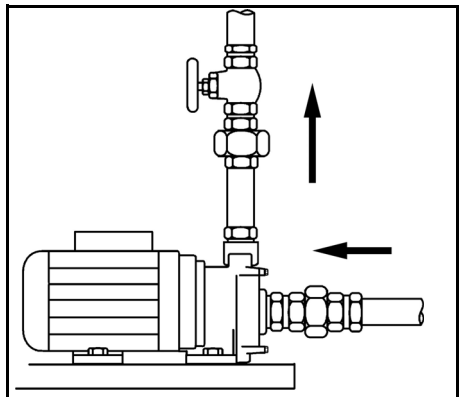

The performance of your pump will be affected by the diameter of the inlet pipe - any restriction will greatly reduce the flow. We recommend that you always use a pipe diameter at least equal to, or greater than the diameter of the pump connections.

To prevent unnecessary strain ensure that adequate support is provided to the hoses and pipes. They will be considerably heavier when filled with water.

It is suggested that suction and delivery isolation valves are fitted in order to isolate the pump. A gate valve may be installed in-line on the delivery side of the pump which can be adjusted as required to regulate the flow of water and can assist in priming the pump.

Protect the pump and pipework from freezing with the addition of suitable lagging. The formation of ice may cause serious damage.

SUCTION LIFT OR GRAVITY FEED

The diagrams illustrate possible methods of pipework installation.

It is possible to draw water from a sunken pool or well providing the suction lift does not exceed the distance specified for your pump.

- The suction lift i.e. the vertical distance between the water level and the pump should not exceed 8 metres.

When suction lift is used to draw water into the pump it is essential that all connections and hoses are completely air tight, otherwise the system will not work.

However, the pump may be gravity fed, that is, drawing water from an above ground tank.

A foot valve/filter should be fitted to the lower end of the suction hose, (as illustrated), to help retain water in the suction system. Remember.... this is NOT a self priming pump.

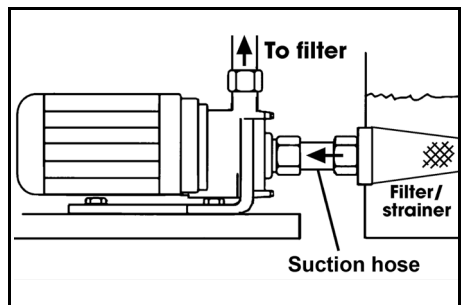
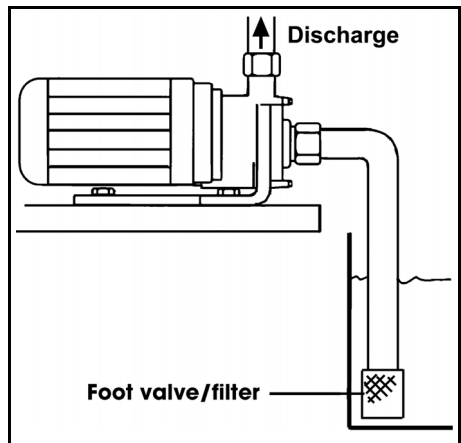

PRIMING THE PUMP

Before pumping, you must completely fill the suction side with water to prime the pump which is carried out as follows:-

1. With all inlet pipes/hoses and foot valve in position, but no outlet hose connected, pour water into the outlet port until all the air is expelled.
2. Connect the outlet hose to the outlet port. If the outlet hose is already connected, a priming hole and threaded plug are provided, adjacent to the outlet as shown.

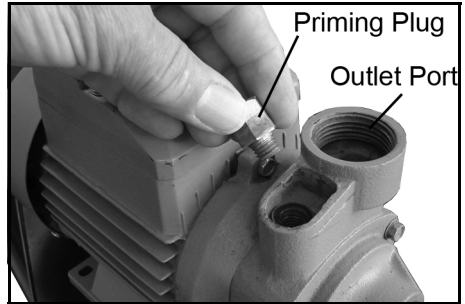

NOTE: As the priming hole is quite small, it is recommended to fill the inlet pipe with water before connecting to the pump, and top up through the priming hole once the pipe is connected.

3. Switch on the pump.
 - Water should start to flow through the system.
4. Check for leaks and make good if necessary.
5. Adjust any device which may be fitted to the outlet side of the pump, to maximise efficiency.

Do not place any restriction on the inlet side of the pump.

Remember - this pump is designed for pumping CLEAN WATER ONLY. DO NOT USE for pumping chemicals or other flammable or corrosive liquids.

OPERATION

1. Open any valves in the pipeline.
2. If operating the pump for the first time, prime the pump as described.

NOTE: The pump is only self-priming when filled with water. Refilling is only necessary if the pump has been drained, or if all the water has been lost.

3. Connect to the power supply and switch on. Water should start to flow through the system. Check for any leaks and make good as necessary.
 - If the motor fails to start, or the pump does not deliver water, refer to TROUBLESHOOTING. Never operate the pump when not primed with water or if the inlet is blocked.

NOTE: Filling the suction pipe with water will speed up the priming process, and it is suggested that a non-return valve be fitted to the end of the suction pipe.

4. Stop the pump by switching off the power supply.

CARE DURING USE

1. Do not allow the pump to run dry, otherwise the seal between the pump and motor may be damaged. If a leak occurs at this point, allowing water to pass from the pump to the motor, take the pump to your Clarke dealer for overhaul.
2. In the event of a blockage, where debris has entered the suction chamber, it can be cleaned out as described under MAINTENANCE.
3. Should contaminants come into contact with the pump, flush through with cold water as soon as possible to prevent damage to the pump. DO NOT USE for pumping chemicals or other corrosive liquids (other than pool purification chemicals in their correct mix ratio).
4. If the pump is being used to drain a pool or pond, ensure there is adequate drainage and there is no risk of damage to property as a result of water being discharged. If a flexible hose must be laid across a roadway, protect it with wooden planking.

MAINTENANCE

The only maintenance required is a regular inspection to ensure that debris is not blocking the passage of water through the pump.

If you suspect the pump is blocked by silt, leaf debris etc, disconnect it from the power supply and back-flush to clear any blockage using a hose. You will need to disconnect the outlet hose to do this.

Always keep the pump in a clean condition, checking regularly for loose bolts or a damaged power cable etc.

The pump should not be taken apart by the user in the case of overhaul being required, but should be taken to your nearest Clarke dealer for specialist repair.

AFTER USE

After use, and if the pump will not be used over the winter period, or whenever there is danger of freezing, always drain the pump body. If the pump has been used with contaminated or salty water, it should be thoroughly flushed with clean water following use, both inside and out. It should then be drained and covered over, if not already installed in a clean, dry environment sheltered from the weather.

Remember to re-prime the pump when returning to service.

- In the event that dismantling and overhaul of the pump is necessary, contact your Clarke service department.

ENVIRONMENTAL PROTECTION

Through the purchase of this product, the customer is taking on the obligation to deal with any waste electrical/electronic equipment in accordance with the WEEE Regulations in relation to the treatment, recycling, recovery and environmentally sound disposal of the WEEE.

- Any redundant accessories and packaging should be sorted and taken to a recycling centre to be disposed of appropriately.

ACCESSORIES

A wide range of accessories is available, including foot valve filters, suction and layflat hoses and clips, couplings and 90° hose adaptors, etc.

- Contact your Clarke dealer for further information. The use of parts other than genuine Clarke replacement parts may result in possible safety hazards or decreased pump performance and will invalidate your warranty.

TROUBLESHOOTING

Problem	Cause	Solution
Pump does not run.	Thermal protection has been activated.	If the motor has overheated, wait for it to cool down before trying again.
	Faulty power connection	Insert plug securely.
	No mains supply	Check fused power supply and replace fuse if necessary (check fuse rating). Check circuit breaker
	Impeller seized/blocked	Disconnect pump from power supply. Investigate cause and clear blockage
Pump fails to prime	Air leaks through suction hose joints (damaged hose, broken clamp, damaged).	Repair connections/ replace hose as necessary.
	Blocked inlet hose	Check pipeline for blockage. Check any inlet valve fitted is fully open.
Pump runs but gives poor output	Congested material inside pump	Clean out & backflush pump.
	Suction or delivery line obstructed.	Remove obstruction and ensure there are no kinks in delivery line.
	Inlet pipe leakage.	Check inlet pipe and connector for leaks. Tighten as required.
	Air leaks through damaged seal.	Renew seal.
	Impeller damaged and making poor seal.	Return to your Clarke dealer for repair
	Impeller / mechanical seal is badly worn.	Return to your Clarke dealer for repair.

	High friction losses in the suction line.	Avoid unnecessary curves, restrictions or valves
	Pump badly sited resulting in suction lift too high	Set pump as close as possible to the level of the water to be pumped
Sudden loss of flow.	Blockage of inlet pipe	Check pipeline for blockage.
Undue vibration or noise.	Excessive flow of water.	Decrease flow of water. by adjusting inlet/outlet valves in system.
	Resistance in inlet pipe caused by obstruction.	Check pipe and clean out as necessary
	Loose rotating component	Return to your dealer for repairs.
	Installation of pump is unstable.	Stop pump and re-position.
	Air pocket in pump or pipeline.	Release plug in impeller housing to release air.
	Damaged impeller	Return to your Clarke dealer for repair.

SPECIFICATION

Water Classification	Clean
Maximum Delivery	40 l/min
Maximum Head	35 m
Maximum Pump Speed	2720 rpm
Maximum Lift (Suction)	8 m
Operating Temperature	0-40°C
Overload type	Thermal Cut-out
Ingress Protection Rating	IPx4 (splash proof)
Operating Voltage & Frequency	230V / 50Hz
Input Wattage@ Maximum Head	383 W
Input Current@ Maximum Head	1.66 A
Outlet Size	1" x 1" (25.4 x 25.4 mm)
Outlet Thread Size	1" BSP
Weight	5.2 kg
Depth x Width x Height	250 x 122 x 150 mm
Sound Pressure Level	62.91 dB LpA
Sound Power Level	74.65 dB LwA
Guaranteed Sound Power Level	77 dB LwA
Uncertain Factor	2.58 (K)

ACCESSORIES

1" BSP Plastic Foot Valve Filter FVF10	Part No:7950680
1" dia Reinforced Suction/Delivery Hose	Part No:7955010
1" dia Layflat Delivery Hose 5M	Part No:7955112
1" dia Layflat Delivery Hose 10M	Part No:7955113
1" BSP Male Coupling	Part No:7950210
1" BSP In-line Water Filter	Part No:7175100

PARTS DIAGRAM

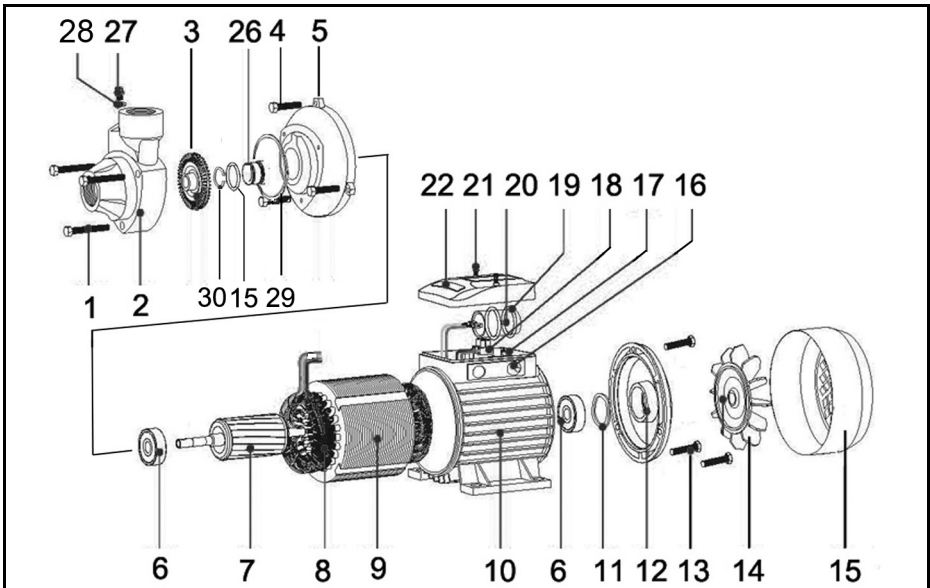

ID	DESCRIPTION	PART NO	ID	DESCRIPTION	PART NO
1	Screw M5 x 40	ZGBIP100001	16	Cable Seal	ZGBIP100016
2	Pump Body	ZGBIP100002	17	Cable Clamp	ZGBIP100017
3	Impeller	ZGBIP100003	18	Terminal Block	ZGBIP100018
4	Screw M5	ZGBIP100004	19	Seal 1	ZGBIP100019
5	Motor Front Cover	ZGBIP100005	20	Capacitor 8uf	ZGBIP100020
6	Ball Bearing 6201-Z2	ZGBIP100006	21	Screw M4	ZGBIP100021
7	Motor Rotor	ZGBIP100007	22	Terminal Cover	ZGBIP100022
8	Motor Stator Coil	ZGBIP100008	23	Connecting Wire	ZGBIP100023
9	Motor Stator	ZGBIP100009	24	Securing Key	ZGBIP100024
10	Motor Body	ZGBIP100010	25	Mechanical Seal	ZGBIP100025
11	Spring Washer	ZGBIP100011	26	Priming Screw	ZGBIP100026
12	Motor End Cover	ZGBIP100012	27	Washer	ZGBIP100027
13	Screw M5	ZGBIP100013	28	O-Ring	ZGBIP100028
14	Fan	ZGBIP100014	29	O-Ring	ZGBIP100029
15	Fan Cover	ZGBIP100015	30	Circlip	ZGBIP100030

DECLARATION OF CONFORMITY



Hemford Street, Epping, Essex, CM16 4AG

DECLARATION OF CONFORMITY

This is an important document and should be retained.



We hereby declare that this product(s) complies with the following directive(s):

- 2014/30/EU Electromagnetic Compatibility Directive.
- 2014/35/EU Low Voltage Equipment Directive.
- 2011/65/EU Restriction of Hazardous Substances (amended by EU 2015/863).
- 2000/14/EC Noise Emissions Directive, (amended by 2005/88/EC).

The following standards have been applied to the product(s):

- EN 55014-1:2006 +A1:2009 +A2:2011, EN 55014-2:2015, EN 61000-3-3:2013, EN 62233:2008,
- EN 61000-3-2:2014, EN 60335-1:2012 +A11:2014, EN 60335-2-41:2009 +A1:2004 +A2:2010.

The technical documentation required to demonstrate that the product(s) meet(s) the requirement(s) of the aforementioned directive(s) has been compiled and is available for inspection by the relevant enforcement authorities.

The CE mark was first applied in: 2012

Signed:

J.A. Clarke
Director



Hemford Street, Epping, Essex CM16 4AG

DECLARATION OF CONFORMITY

This is an important document and should be retained.



Product Description: 1" Electric water pump
Model number(s): BIP1000
Serial / batch Number: N/A
Date of Issue: 12/10/2020
(Noise Conformity)
Notified Body: -

Technical Documentation Holder:
A.R. Pond
Clarke International
2a Strubland Road
London E10 7RB
UK

Conformity Assessment Procedure: to 2000/14/EC Annex V
Manufacturer: Clarke International
Noise Related Value: 0.37 kW
Measured Sound Power Level: 73 dB
Guaranteed Sound Power Level: 75 dB

A SELECTION FROM THE VAST RANGE OF

Clarke®

QUALITY PRODUCTS



AIR COMPRESSORS

From DIY to industrial, Plus air tools, spray guns and accessories.

GENERATORS

Prime duty or emergency standby for business, home and leisure.

POWER WASHERS

Hot and cold, electric and engine driven - we have what you need

WELDERS

Mig, Arc, Tig and Spot. From DIY to auto/industrial.

METALWORKING

Drills, grinders and saws for DIY and professional use.

WOODWORKING

Saws, sanders, lathes, mortisers and dust extraction.

HYDRAULICS

Cranes, body repair kits, transmission jacks for all types of workshop use.

WATER PUMPS

Submersible, electric and engine driven for DIY, agriculture and industry.

POWER TOOLS

Angle grinders, cordless drill sets, saws and sanders.

STARTERS/CHARGERS

All sizes for car and commercial use.



PARTS & SERVICE: 0208 988 7400

Parts Enquiries
Parts@clarkeinternational.com

Servicing & Technical Enquiries
Service@clarkeinternational.com

SALES: UK 01992 565333 or Export 00 44 (0)1992 565335

Clarke INTERNATIONAL Hemnall Street, Epping, Essex CM16 4LG
www.clarkeinternational.com