

Qty. Description

1 **SLV.65.65 .11.A.2.1.502**



Note! Product picture may differ from actual product

Product No.: [96106575](#)

Non-self-priming, single-stage, centrifugal pump designed for handling wastewater, process water and unscreened raw sewage.

The pump is designed for intermittent and continuous operations in submerged installation. The efficient SuperVortex impeller provides passage of long fibres and solids and is suitable for wastewater with a dry matter content of up to 5 %. A unique stainless-steel clamp assembling system enables quick and easy disassembly of the pump from the motor unit for service and inspection. No special tools are required. Pipework connection is via a DIN flange.

Further product details

The pump is suitable for both temporary and permanent installation either as free-standing on ring stand or on an auto-coupling system.

Pump

The pump housing, motor top and impeller are made of cast iron (EN-GJL-250).

All surfaces of the cast iron parts are protected with cathodolysis coating.

The surface of the cast iron pump parts is afterwards painted with environmental friendly powder coating (type NCS 9000N (black), gloss code 30, thickness 100 µm) which ensures high impact and corrosion protection.

The final pump is assembled from already painted parts which ensures that no rust or scale can be formed in grooves between parts, etc.

The SuperVortex impeller is a symmetrical multivane winglet impeller.

The design ensures a flow entirely outside the impeller providing limited contact between the impeller and the pumped liquid.

This ensures that long fibres, rags and more passes freely through the pump without getting caught and without causing clogging or jamming.



The shaft seal consists of two mechanical seals that ensure a reliable sealing between the pumped liquid and motor. The shaft seals are incorporated in a single-unit cartridge shaft seal system that is easy to replace in the field without use of special tools.

The combination of the primary and secondary seals in a cartridge shaft seal system results in a shorter assembly length compared to conventional shaft seals.

- Primary seal: Silicon carbide/silicon carbide (SiC/SiC)
- Secondary seal: Carbon/Ceramics

The shaft seal is bidirectional, meaning it operates correctly in case of backflow through the pump.

Qty. Description

1



The pump is approved according to LGA.

Motor

The motor is a watertight, totally encapsulated motor supplied with a 10 m power cable. The stainless steel plug is fastened with a union nut. This nut and the O-rings provide sealing against ingress of the liquid.

The plug is polyurethane-embedded, ensuring a watertight and durable seal around the leads of the cable. This prevents the ingress of water into the motor through the cable in case of cable breakage or adverse handling in connection with installation or service.

A compact motor construction with a short shaft reduces vibrations, resulting in an increased efficiency and lifetime of the shaft seal and ball bearings.

The motor features built-in thermal protection to protect the motor against overheating and ensure the reliability.

The pump is designed for speed-controlled operation to keep the energy consumption at a minimum.

To avoid the risk of sedimentation in the pipes, we recommend that you operate the speed-controlled pump within a speed range of 30 % to 100 % and at a flow rate above 1 m/s.

Controls:

Moisture sensor: without moisture sensors
 Water-in-oil sensor: without water-in-oil sensor
 AUTOADAPT: NO

Liquid:

Liquid temperature range: 0 .. 40 °C
 Density: 998.2 kg/m³

Technical:

Maximum flow: 11.9 l/s
 Type of impeller: SUPER VORTEX
 Maximum particle size: 65 mm
 Primary shaft seal: SIC/SIC
 Approvals: LGA
 Curve tolerance: ISO9906:2012 3B2
 Rated speed: 2830 rpm

Materials:

Pump housing: Cast iron
 EN-GJL-250
 Impeller: Cast iron
 EN-GJS-400-15
 Motor: EN-GJL-200

Installation:

Range of ambient temperature: 0 .. 40 °C
 Maximum operating pressure: 6 bar
 Flange standard: DIN
 Type of outlet connection: DIN
 Size of outlet connection: DN 65
 Pressure rating: PN 10
 Maximum installation depth: 10 m
 Auto-coupling: 96090992

Electrical data:

Power input - P1: 1.6 kW
 Rated power - P2: 1.1 kW



Company name:

Created by:

Phone:

Date:

02/01/2023

Qty. Description

1	Mains frequency:	50 Hz
	Rated voltage:	1 x 230 V
	Voltage tolerance:	+6/-10 %
	Max starts per. hour:	30
	Rated current:	7.4 A
	Rated current at 3/4 load:	5.8 A
	Rated current at 1/2 load:	4.5 A
	Starting current:	38 A
	Rated current at no load:	2.6 A
	Cos phi - power factor:	0.97
	Cos phi - p.f. at 3/4 load:	0.96
	Cos phi - p.f. at 1/2 load:	0.89
	Rated speed:	2830 rpm
	Motor efficiency at full load:	67 %
	Motor efficiency at 3/4 load:	66 %
	Motor efficiency at 1/2 load:	60 %
	Start. method:	direct-on-line
	Enclosure class (IEC 34-5):	IP68
	Insulation class (IEC 85):	F
	Explosion proof:	no
	Length of power cable:	10 m
	Cable type:	H07RN-F
	Others:	
	Net weight:	47.5 kg
	Danish VVS No.:	391296333

96106575 SLV.65.65 .11.A.2.1.502 50 Hz

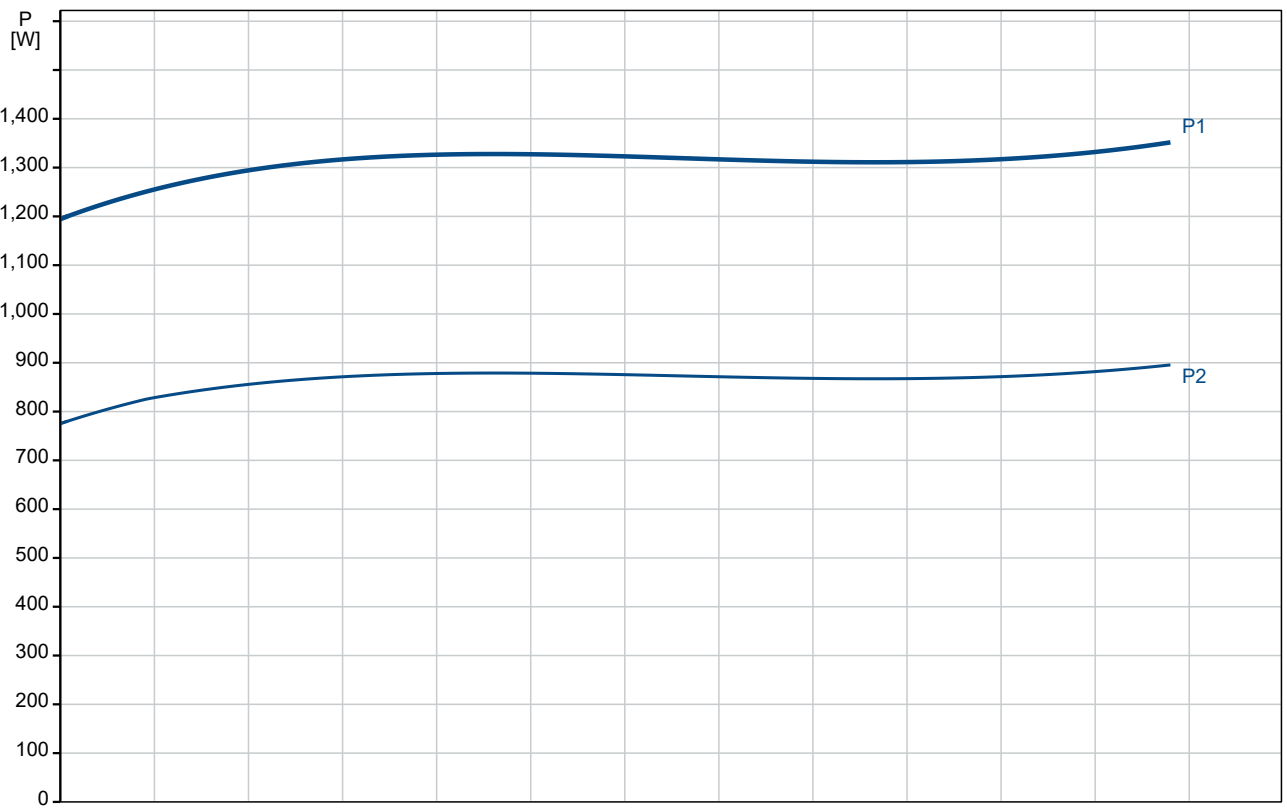
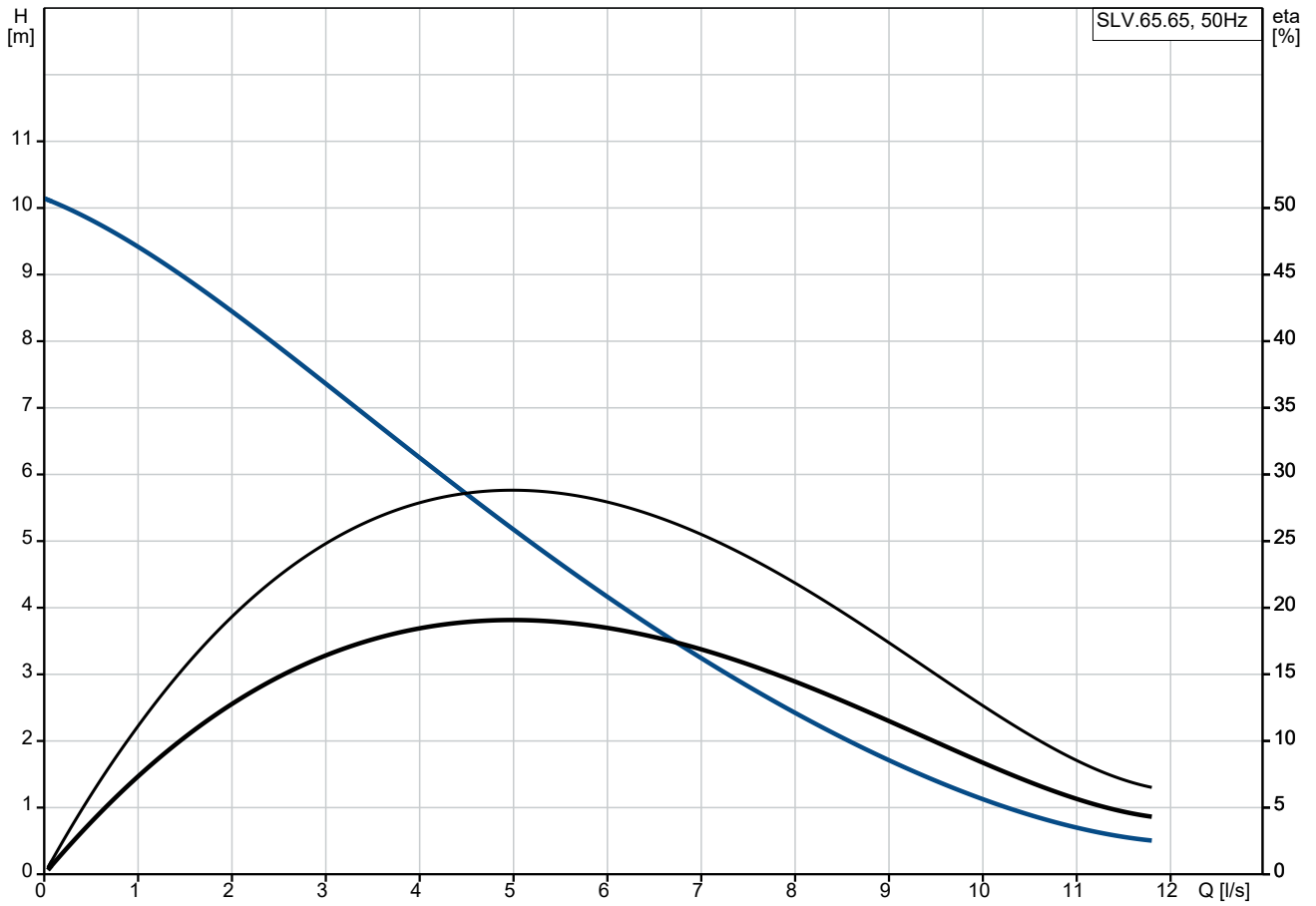

Description	Value
General information:	
Product name:	SLV.65.65 .11.A.2.1.502
Product No:	96106575
EAN number:	5700396855530
Technical:	
Maximum flow:	11.9 l/s
Maximum head:	9.5 m
Type of impeller:	SUPER VORTEX
Maximum particle size:	65 mm
Primary shaft seal:	SIC/SIC
Approvals:	LGA
Curve tolerance:	ISO9906:2012 3B2
Cooling jacket:	without cooling jacket
Rated speed:	2830 rpm
Materials:	
Pump housing:	Cast iron
Pump housing:	EN-GJL-250
Impeller:	Cast iron
Impeller:	EN-GJS-400-15
Motor:	EN-GJL-200
Installation:	
Range of ambient temperature:	0 .. 40 °C
Maximum operating pressure:	6 bar
Flange standard:	DIN
Type of outlet connection:	DIN
Size of outlet connection:	DN 65
Pressure rating:	PN 10
Maximum installation depth:	10 m
Inst dry/wet:	SUBMERGED
Installation:	Vertical
Auto-coupling:	96090992
Liquid:	
Liquid temperature range:	0 .. 40 °C
Density:	998.2 kg/m ³
Electrical data:	
Power input - P1:	1.6 kW
Rated power - P2:	1.1 kW
Mains frequency:	50 Hz
Rated voltage:	1 x 230 V
Voltage tolerance:	+6/-10 %
Max starts per. hour:	30
Rated current:	7.4 A
Rated current at 3/4 load:	5.8 A
Rated current at 1/2 load:	4.5 A
Starting current:	38 A
Rated current at no load:	2.6 A
Cos phi - power factor:	0.97
Cos phi - p.f. at 3/4 load:	0.96
Cos phi - p.f. at 1/2 load:	0.89
Rated speed:	2830 rpm
Motor efficiency at full load:	67 %
Motor efficiency at 3/4 load:	66 %
Motor efficiency at 1/2 load:	60 %
Start. method:	direct-on-line
Enclosure class (IEC 34-5):	IP68
Insulation class (IEC 85):	F
Explosion proof:	no
Built-in motor protection:	THERMAL SWITCH

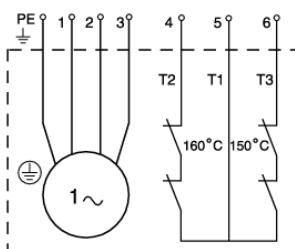
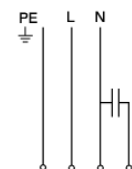
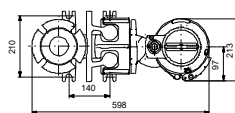
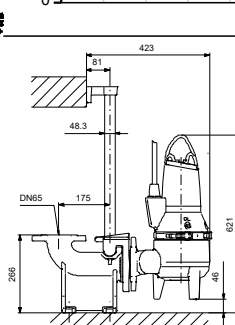
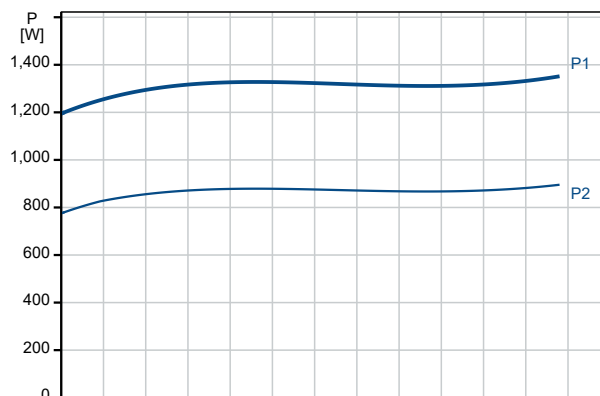
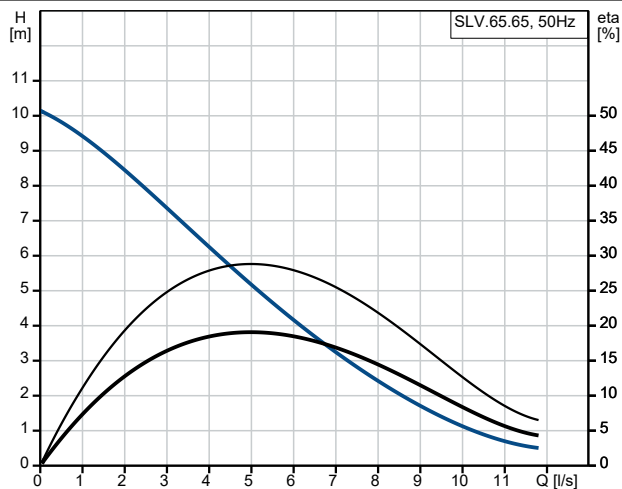



Company name:

Created by:

Phone:

Date:

02/01/2023

Description	Value
Length of power cable:	10 m
Cable type:	H07RN-F
Controls:	
Control box:	control box included
Moisture sensor:	without moisture sensors
Water-in-oil sensor:	without water-in-oil sensor
AUTOADAPT:	NO
Others:	
Net weight:	47.5 kg
Danish VVS No.:	391296333

96106575 SLV.65.65 .11.A.2.1.502 50 Hz

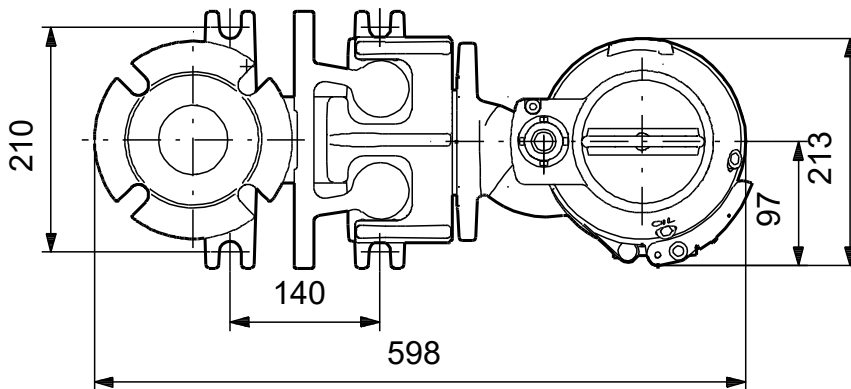
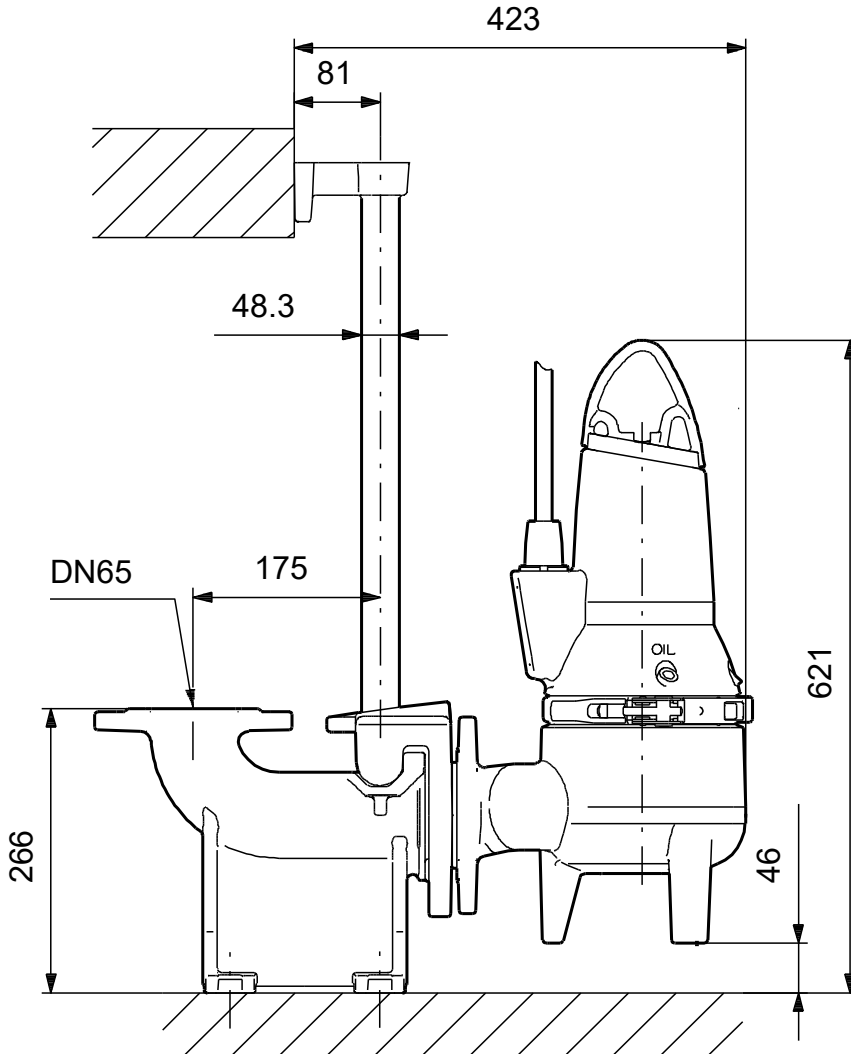

Note! All units are in [mm] unless others are stated.
Disclaimer: This simplified dimensional drawing does not show all details.

96106575 SLV.65.65 .11.A.2.1.502 50 Hz

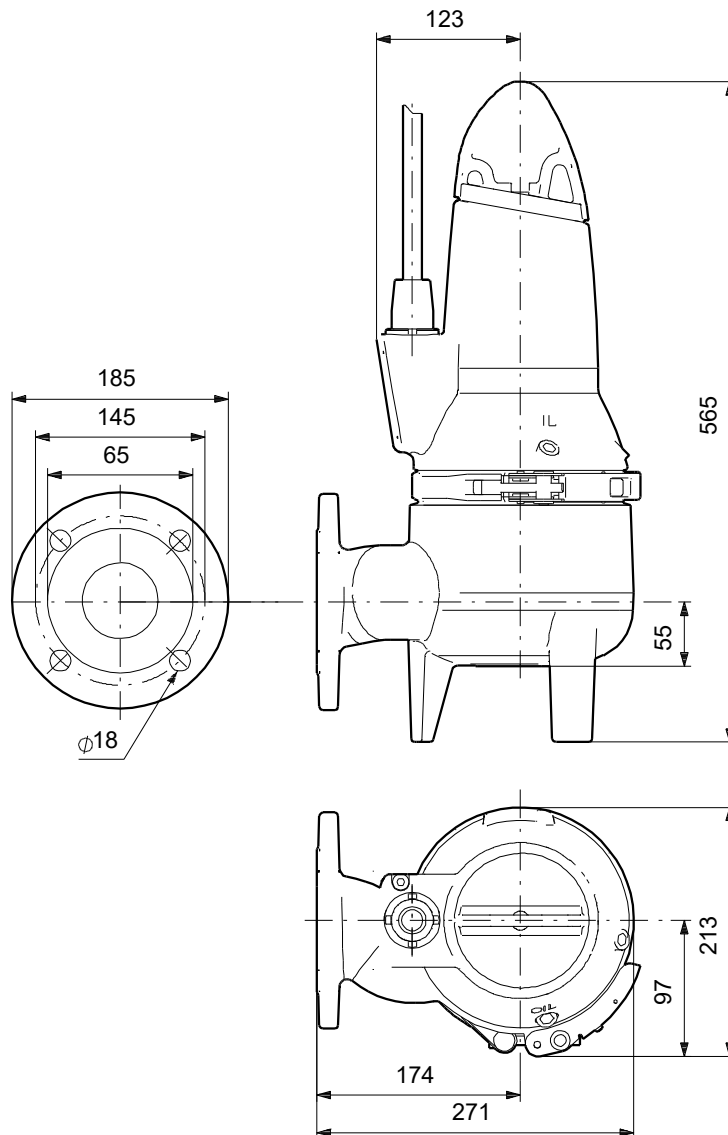

Note! All units are in [mm] unless others are stated.
Disclaimer: This simplified dimensional drawing does not show all details.

96106575 SLV.65.65 .11.A.2.1.502 50 Hz

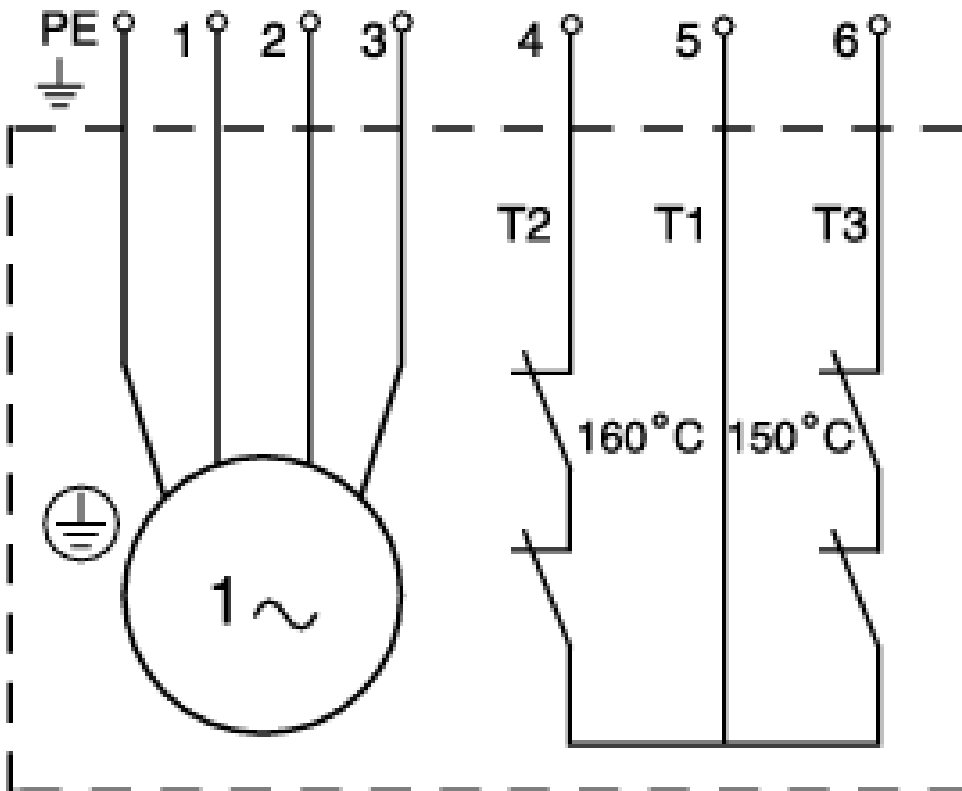
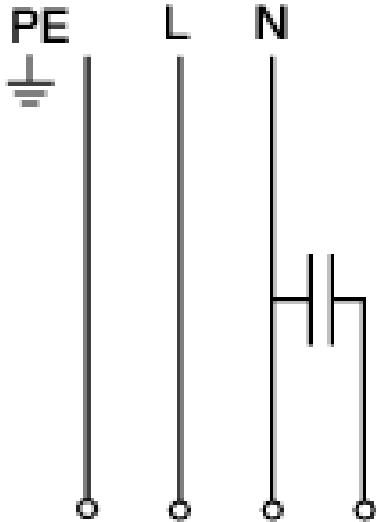

Note! All units are in [mm] unless others are stated.

