

**Qty. Description**

1 CRN 15-17 A-FGJ-H-E-HQQE



Note! Product picture may differ from actual product

Product No.: [96527796](#)

Vertical, multistage centrifugal pump with inlet and outlet ports on same the level (inline). Pump materials in contact with the liquid are in high-grade stainless steel. A cartridge shaft seal ensures high reliability, safe handling, and easy access and service. Power transmission is via a rigid split coupling. Pipe connection is via combined DIN-ANSI-JIS flanges.

The pump is fitted with a 3-phase, fan-cooled asynchronous motor.

**Further product details**

Steel, cast iron and aluminium components have an epoxy-based coating made in a cathodic electro-deposition (CED) process.

CED is a high-quality dip-painting process where an electrical field around the products ensures deposition of paint particles as a thin, well-controlled layer on the surface.

An integral part of the process is a pretreatment.

The entire process consists of these elements:

- 1) Alkaline-based cleaning.
- 2) Zinc phosphating.
- 3) Cathodic electro-deposition.
- 4) Curing to a dry film thickness 18-22 my m.

The colour code for the finished product is NCS 9000/RAL 9005.

**Pump**

A long split coupling connects the pump and motor shaft. It is enclosed in the motor stool by means of two coupling guards. The long coupling makes it possible to replace the shaft seal without removing the motor from the pump.

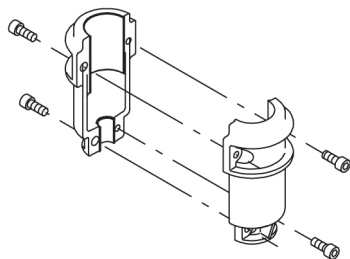

The pump head and flange for motor mounting is made in one piece (cast iron). The pump head cover is a separate component (stainless steel). The pump head has a combined 1/2" priming plug and vent screw.

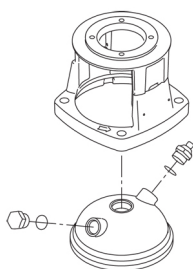

**Qty. Description**

1 The pump is fitted with a balanced O-ring seal unit with a rigid torque-transmission system. This seal type is assembled in a cartridge unit which makes replacement safe and easy. Due to the balancing, this seal type is suitable for high-pressure applications. The cartridge construction also protects the pump shaft from possible wear from a dynamic O-ring between pump shaft and shaft seal.

Seal faces:

- Rotating seal ring material: silicon carbide (SiC)
- Stationary seat material: silicon carbide (SiC)

This material pairing is used where higher corrosion resistance is required. The high hardness of this material pairing offers good resistance against abrasive particles.

Secondary seal material: EPDM (ethylene-propylene rubber)  
EPDM has excellent resistance to hot water. EPDM is not suitable for mineral oils.

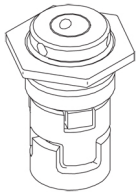

The shaft seal is screwed into the pump head.

The chambers and impellers are made of stainless-steel sheet. The chambers are provided with a PTFE neck ring offering improved sealing and high efficiency. The impellers have smooth surfaces, and the shape of the blades ensure a high efficiency.

The pump has a stainless steel base mounted on a separate base plate.

This base and base plate are kept in position by the tension of the staybolts which hold the pump together.

The outlet side of the base has a combined drain plug and bypass valve.

The pump is secured to the foundation by four bolts through the base plate.

The flanges and base are cast in one piece and prepared for connection by means of DIN, ANSI or JIS.

**Motor**

The motor is a totally enclosed, fan-cooled motor with principal dimensions to IEC and DIN standards. The motor is flange-mounted with free-hole flange (FF).

Motor-mounting designation in accordance with IEC 60034-7: IM B 5 (Code I) / IM 3001 (Code II).

Electrical tolerances comply with IEC 60034.

The motor efficiency is classified as IE3 in accordance with IEC 60034-30-1.

The motor has thermistors (PTC sensors) in the windings in accordance with DIN 44081/DIN 44082. The protection reacts to both slow- and quick-rising temperatures, e.g. constant overload and stalled conditions.

Thermal switches must be connected to an external control circuit in a way which ensures that the automatic reset cannot cause accidents. The motors must be connected to a motor-protective circuit breaker according to local regulations.

The motor can be connected to a variable speed drive for adjustment of pump performance to any duty point. Grundfos CUE offers a range of variable speed drives. Please find more information in Grundfos Product Center.

**Technical data**

Liquid:

Pumped liquid: Water  
Liquid temperature range: -20 .. 120 °C  
Selected liquid temperature: 20 °C  
Density: 998.2 kg/m<sup>3</sup>

Technical:

Pump speed on which pump data are based: 2923 rpm  
Rated flow: 17 m<sup>3</sup>/h  
Rated head: 191.9 m  
Pump orientation: Vertical  
Shaft seal arrangement: Single  
Code for shaft seal: HQQE

Qty.	Description
1	<p>Approvals: CE,EAC,UKCA,SEPRO  Approvals for drinking water: WRAS,ACS  Curve tolerance: ISO9906:2012 3B</p> <p>Materials:  Base: Stainless steel  EN 1.4408  AISI 316  Impeller: Stainless steel  EN 1.4401  AISI 316  Bearing: SIC</p> <p>Installation:  t max amb: 60 °C  Maximum operating pressure: 25 bar  Max pressure at stated temp: 25 bar / 120 °C  25 bar / -20 °C  Type of connection: DIN / ANSI / JIS  Size of inlet connection: DN 50  Size of outlet connection: DN 50  Pressure rating for connection: PN 25  Flange rating inlet: 300 lb  Flange size for motor: FF300</p> <p>Electrical data:  Motor standard: IEC  Motor type: 160MD  IE Efficiency class: IE3  Rated power - P2: 15 kW  Power (P2) required by pump: 15 kW  Mains frequency: 50 Hz  Rated voltage: 3 x 380-415D/660-690Y V  Rated current: 28,0-26,0/16,2-15,6 A  Starting current: 660-780 %  Cos phi - power factor: 0.89-0.87  Rated speed: 2930-2950 rpm  Efficiency: IE3 91,9%  Motor efficiency at full load: 91.9-91.9 %  Motor efficiency at 3/4 load: 92.4 %  Motor efficiency at 1/2 load: 92.4 %  Number of poles: 2  Enclosure class (IEC 34-5): 55 Dust/Jetting  Insulation class (IEC 85): F  Motor No: 85U17526</p> <p>Controls:  Frequency converter: NONE</p> <p>Others:  Minimum efficiency index, MEI ≥: 0.70  Net weight: 169 kg  Gross weight: 200 kg  Shipping volume: 0.619 m<sup>3</sup>  Country of origin: GB  Custom tariff no.: 84137075</p>



Company name:

Created by:

Phone:

Date:

02/01/2023

### 96527796 CRN 15-17 A-FGJ-H-E-HQQE 50 Hz

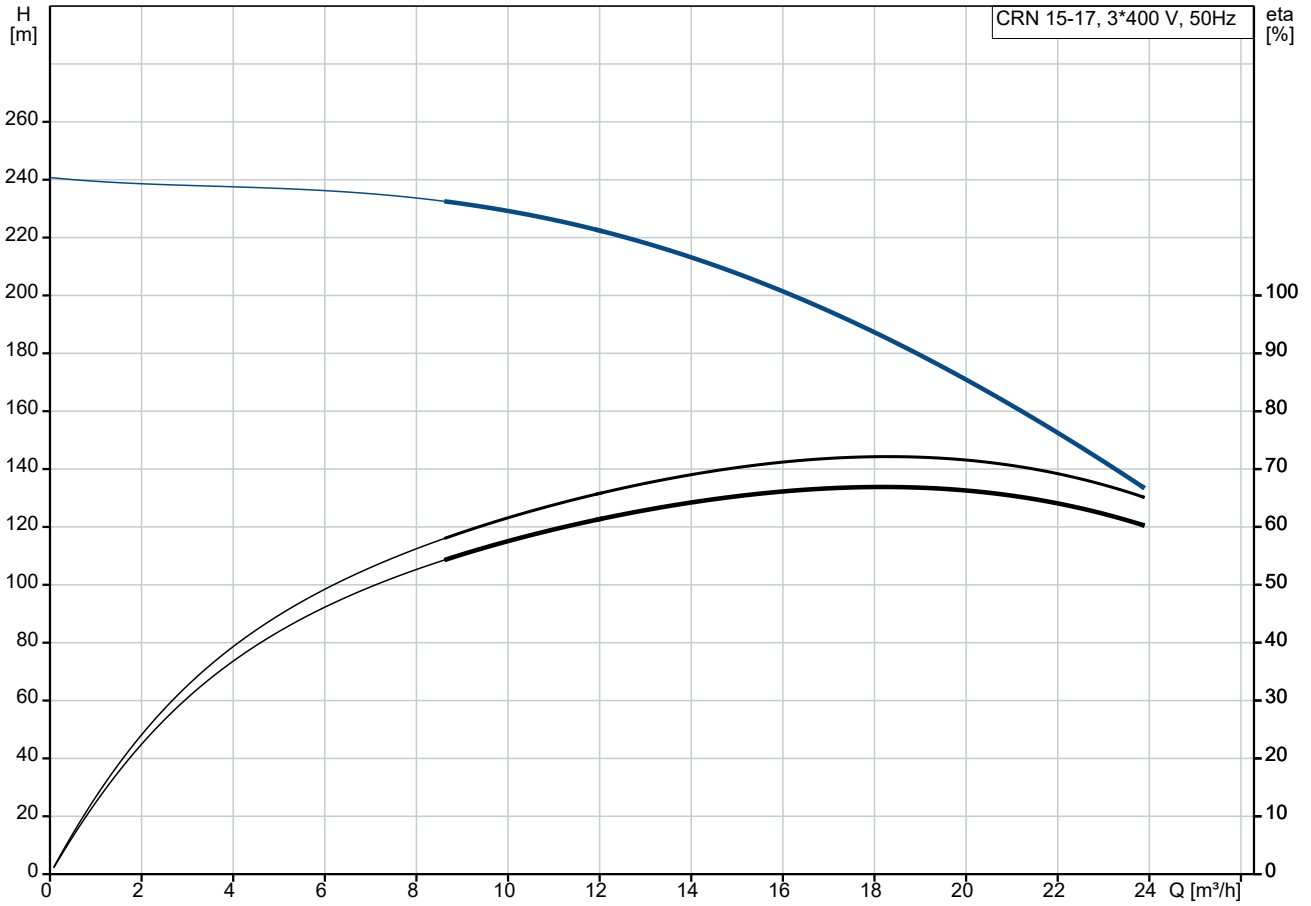

Pumped liquid = Water  
Liquid temperature during operation = 20 °C  
Density = 998.2 kg/m³

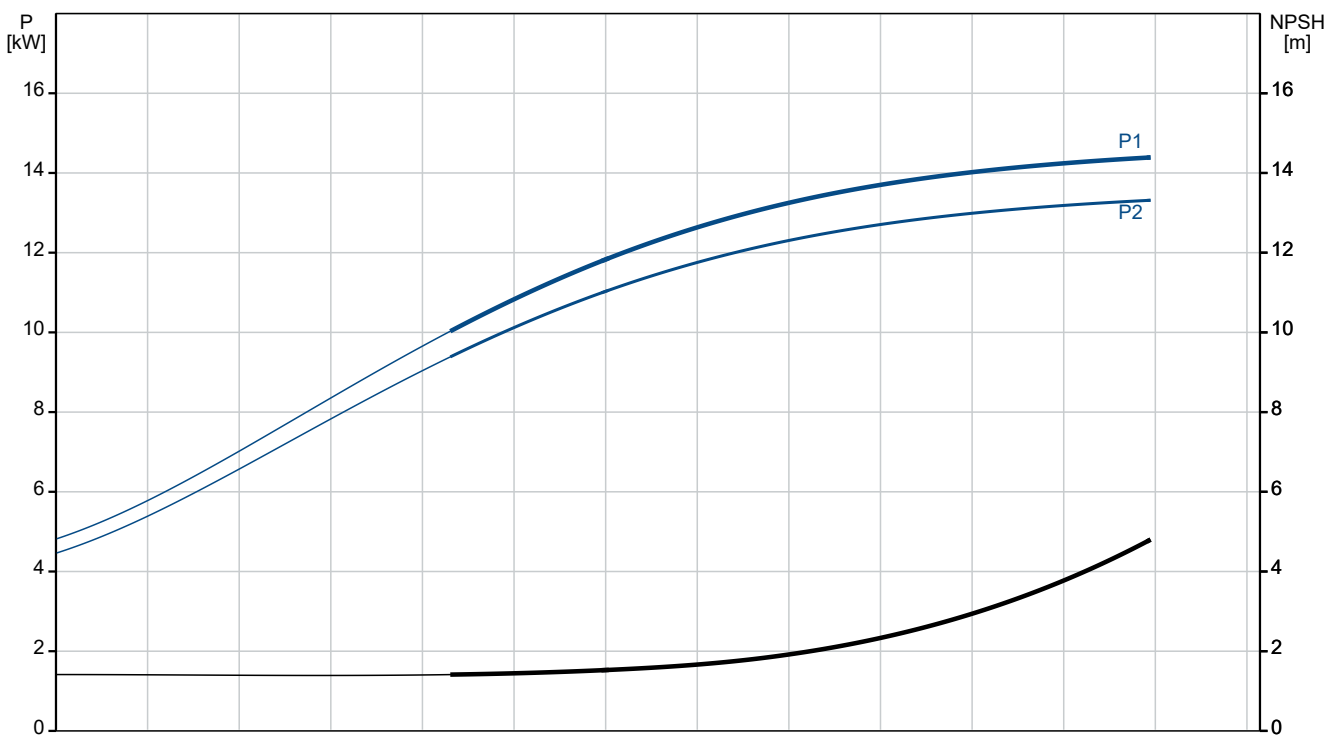





Company name:

Created by:

Phone:

Date:

02/01/2023

Description	Value
Rated current:	28,0-26,0/16,2-15,6 A
Starting current:	660-780 %
Cos phi - power factor:	0.89-0.87
Rated speed:	2930-2950 rpm
Efficiency:	IE3 91,9%
Motor efficiency at full load:	91.9-91.9 %
Motor efficiency at 3/4 load:	92.4 %
Motor efficiency at 1/2 load:	92.4 %
Number of poles:	2
Enclosure class (IEC 34-5):	55 Dust/Jetting
Insulation class (IEC 85):	F
Built-in motor protection:	PTC
Motor No:	85U17526
<b>Controls:</b>	
Frequency converter:	NONE
<b>Others:</b>	
Minimum efficiency index, MEI ≥:	0.70
Net weight:	169 kg
Gross weight:	200 kg
Shipping volume:	0.619 m <sup>3</sup>
Sales region:	Great Britain
Country of origin:	GB
Custom tariff no.:	84137075

**96527796 CRN 15-17 A-FGJ-H-E-HQQE 50 Hz**

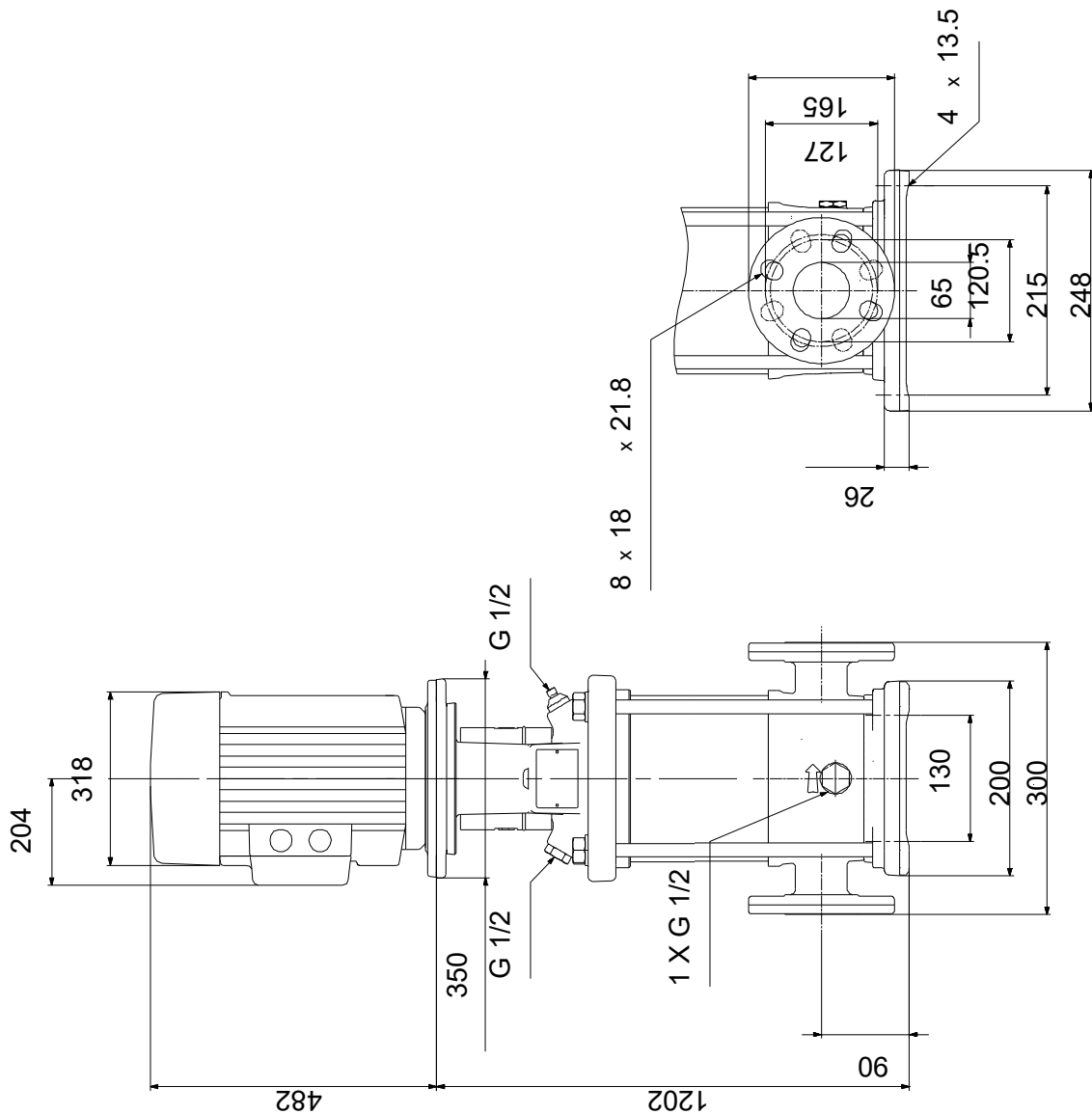

Note! All units are in [mm] unless others are stated.  
Disclaimer: This simplified dimensional drawing does not show all details.

## 96527796 CRN 15-17 A-FGJ-H-E-HQQE 50 Hz



IEC TP211 THERMALLY PROTECTED WHEN THE THERMISTORS ARE  
CONNECTED TO AMPLIFIER RELAY FOR CONTROL OF MAIN SUPPLY  
THERMISTORS PTC ACCORDING TO DIN 44082

Note! All units are in [mm] unless others are stated.

