

| Qty. | Description |
|------|--|
| 1 | CRN 32-4-2 A-F-H-E-HQQE |
| |  |
| | <p align="center">Note! Product picture may differ from actual product</p> |
| | <p>Product No.: On request</p> |
| | <p>Vertical, multistage centrifugal pump with inlet and outlet ports on same the level (inline). Pump materials in contact with the liquid are in high-grade stainless steel. A cartridge shaft seal ensures high reliability, safe handling, and easy access and service. Power transmission is via a rigid split coupling. Pipe connection is via DIN flanges.</p> |
| | <p>The pump is fitted with a 3-phase, fan-cooled asynchronous motor.</p> |
| | <p>Liquid: Pumped liquid: Water Liquid temperature range: -40 .. 120 °C Selected liquid temperature: 20 °C Density: 998.2 kg/m³</p> |
| | <p>Technical: Pump speed on which pump data are based: 2919 rpm Rated flow: 30 m³/h Rated head: 53.1 m Pump orientation: Vertical Shaft seal arrangement: Single Code for shaft seal: HQQE Approvals: CE,EAC,UKCA,SEPRO Approvals for drinking water: WRAS,ACS Curve tolerance: ISO9906:2012 3B</p> |
| | <p>Materials: Base: Stainless steel EN 1.4408 AISI 316 Impeller: Stainless steel EN 1.4401 AISI 316 Bearing: SIC Support bearing: Graflon</p> |
| | <p>Installation: t max amb: 60 °C Maximum operating pressure: 16 bar Max pressure at stated temp: 16 bar / 120 °C 16 bar / -40 °C</p> |
| | <p>Type of connection: DIN Size of inlet connection: DN 65 Size of outlet connection: DN 65 Pressure rating for connection: PN 40 Flange size for motor: FF265</p> |
| | <p>Electrical data: Motor standard: IEC Motor type: 132SB IE Efficiency class: IE3 Rated power - P2: 7.5 kW Power (P2) required by pump: 7.5 kW Mains frequency: 50 Hz</p> |

| Qty. | Description |
|------|---|
| 1 | <p>Rated voltage: 3 x 380-415D/660-690Y V</p> <p>Rated current: 14,4-14,0/8,30-8,10 A</p> <p>Starting current: 780-910 %</p> <p>Cos phi - power factor: 0.88-0.82</p> <p>Rated speed: 2910-2920 rpm</p> <p>Efficiency: IE3 90,1%</p> <p>Motor efficiency at full load: 90.1-90.4 %</p> <p>Motor efficiency at 3/4 load: 90.8 %</p> <p>Motor efficiency at 1/2 load: 90.8 %</p> <p>Number of poles: 2</p> <p>Enclosure class (IEC 34-5): 55 Dust/Jetting</p> <p>Insulation class (IEC 85): F</p> <p>Motor No: 85U17522</p> <p>Controls:</p> <p>Frequency converter: NONE</p> <p>Others:</p> <p>Minimum efficiency index, MEI \geq: 0.70</p> <p>Net weight: 111 kg</p> <p>Gross weight: 134 kg</p> <p>Shipping volume: 0.309 m³</p> <p>Country of origin: GB</p> <p>Custom tariff no.: 84137075</p> |

On request CRN 32-4-2 A-F-H-E-HQQE 50 Hz

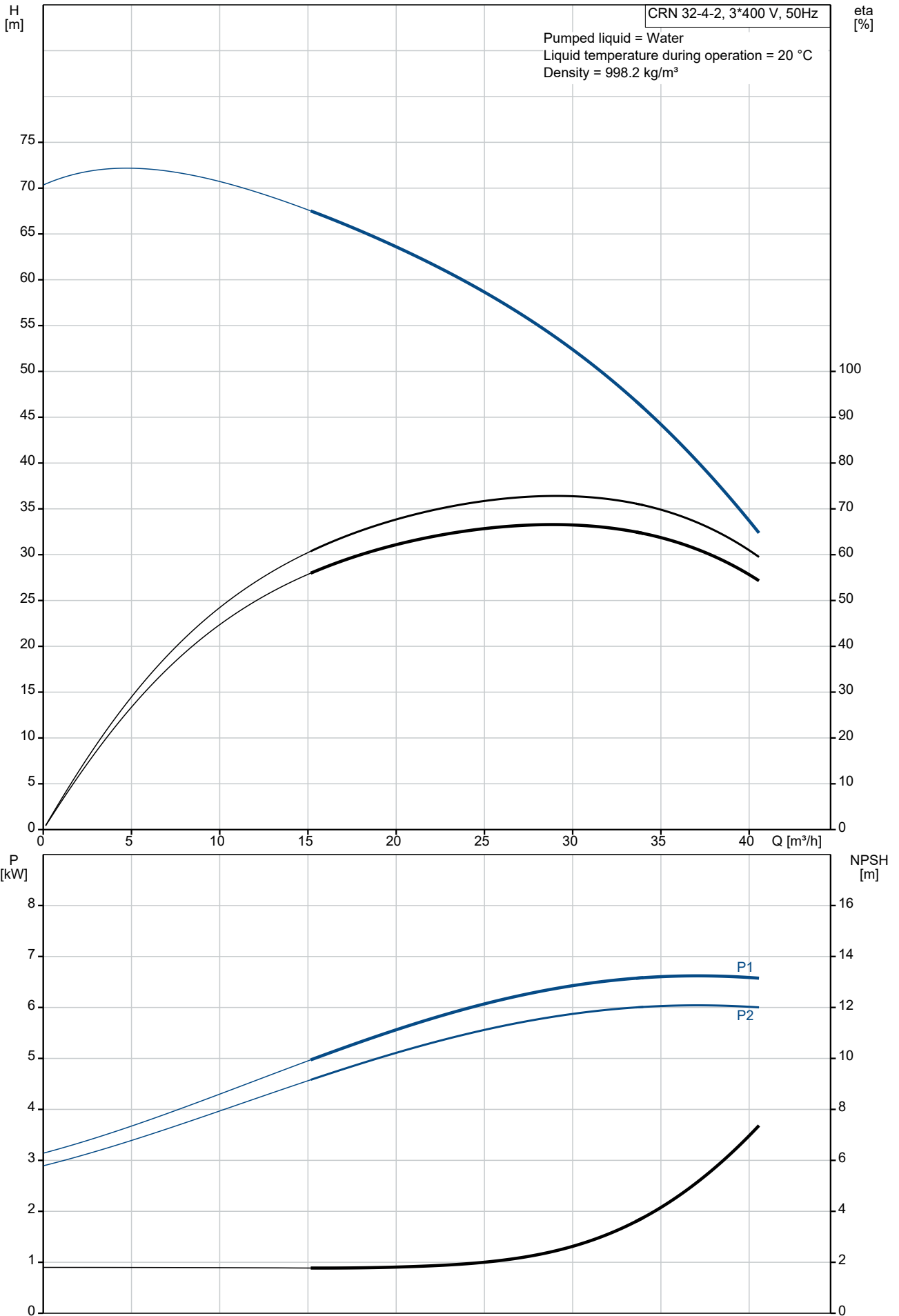

| Description | Value |
|--|----------------------------|
| General information: | |
| Product name: | CRN 32-4-2 A-F-H-E-HQQE |
| Product No: | On request |
| EAN number: | On request |
| Technical: | |
| Pump speed on which pump data are based: | 2919 rpm |
| Rated flow: | 30 m ³ /h |
| Rated head: | 53.1 m |
| Maximum head: | 70.3 m |
| Stages: | 4 |
| Impellers: | 4 |
| Number of reduced-diameter impellers: | 2 |
| Low NPSH: | N |
| Pump orientation: | Vertical |
| Shaft seal arrangement: | Single |
| Code for shaft seal: | HQQE |
| Approvals: | CE,EAC,UKCA,SEPRO |
| Approvals for drinking water: | WRAS,ACS |
| Curve tolerance: | ISO9906:2012 3B |
| Pump version: | A |
| Model: | B |
| Materials: | |
| Base: | Stainless steel |
| Base: | EN 1.4408 |
| Base: | AISI 316 |
| Impeller: | Stainless steel |
| Impeller: | EN 1.4401 |
| Impeller: | AISI 316 |
| Material code: | H |
| Code for rubber: | E |
| Bearing: | SIC |
| Support bearing: | Graflon |
| Installation: | |
| t max amb: | 60 °C |
| Maximum operating pressure: | 16 bar |
| Max pressure at stated temp: | 16 bar / 120 °C |
| Max pressure at stated temp: | 16 bar / -40 °C |
| Type of connection: | DIN |
| Size of inlet connection: | DN 65 |
| Size of outlet connection: | DN 65 |
| Pressure rating for connection: | PN 40 |
| Flange size for motor: | FF265 |
| Connect code: | F |
| Liquid: | |
| Pumped liquid: | Water |
| Liquid temperature range: | -40 .. 120 °C |
| Selected liquid temperature: | 20 °C |
| Density: | 998.2 kg/m ³ |
| Electrical data: | |
| Motor standard: | IEC |
| Motor type: | 132SB |
| IE Efficiency class: | IE3 |
| Rated power - P2: | 7.5 kW |
| Power (P2) required by pump: | 7.5 kW |
| Mains frequency: | 50 Hz |
| Rated voltage: | 3 x 380-415D/660-690Y V |
| Rated current: | 14,4-14,0/8,30-8,10 A |
| Starting current: | 780-910 % |
| Cos phi - power factor: | 0.88-0.82 |
| Rated speed: | 2910-2920 rpm |
| Efficiency: | IE3 90,1% |
| Motor efficiency at full load: | 90.1-90.4 % |

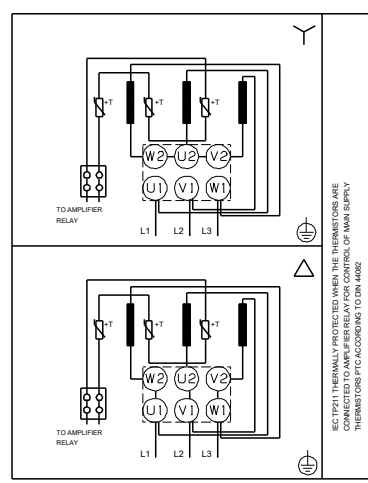
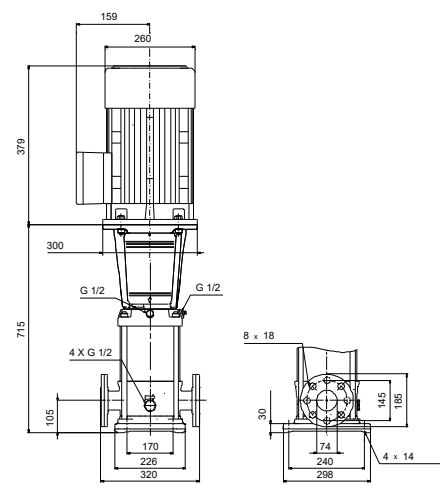
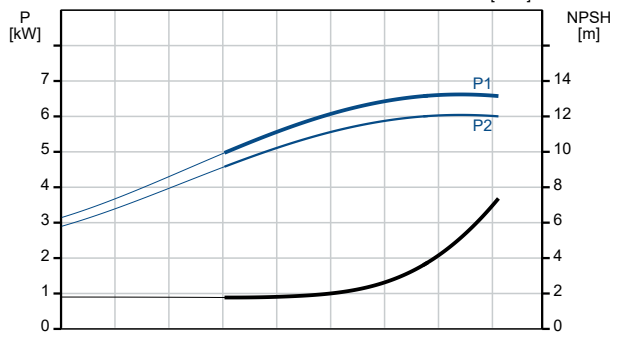
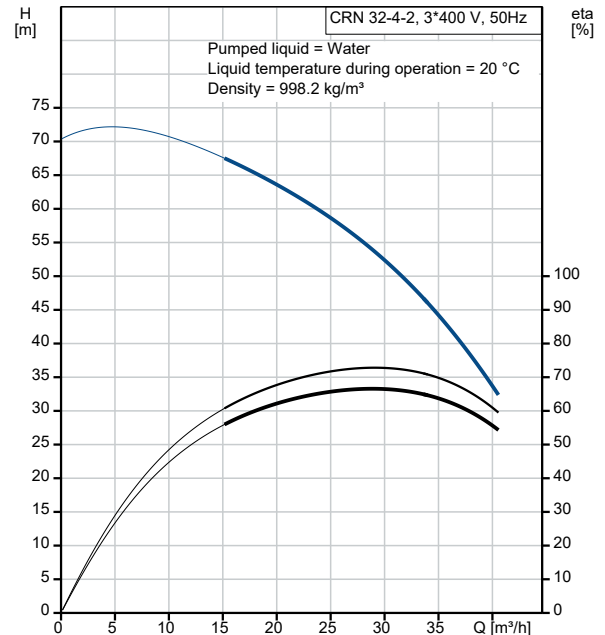

| Description | Value |
|----------------------------------|----------------------|
| Motor efficiency at 3/4 load: | 90.8 % |
| Motor efficiency at 1/2 load: | 90.8 % |
| Number of poles: | 2 |
| Enclosure class (IEC 34-5): | 55 Dust/Jetting |
| Insulation class (IEC 85): | F |
| Built-in motor protection: | PTC |
| Motor No: | 85U17522 |
| Controls: | |
| Frequency converter: | NONE |
| Others: | |
| Minimum efficiency index, MEI ≥: | 0.70 |
| Net weight: | 111 kg |
| Gross weight: | 134 kg |
| Shipping volume: | 0.309 m ³ |
| Sales region: | Great Britain |
| Country of origin: | GB |
| Custom tariff no.: | 84137075 |

On request CRN 32-4-2 A-F-H-E-HQQE 50 Hz



IEC TP211 THERMALLY PROTECTED WHEN THE THERMISTORS ARE
CONNECTED TO AMPLIFIER RELAY FOR CONTROL OF MAIN SUPPLY
THERMISTORS PTC ACCORDING TO DIN 44082

Note! All units are in [mm] unless others are stated.

