

Qty.	Description
1	<b>CRN 45-3 A-F-H-E-HQQE</b>
	
	<p align="center"><b>Note! Product picture may differ from actual product</b></p>
	<p>Product No.: On request</p>
	<p>Vertical, multistage centrifugal pump with inlet and outlet ports on same the level (inline). Pump materials in contact with the liquid are in high-grade stainless steel. A cartridge shaft seal ensures high reliability, safe handling, and easy access and service. Power transmission is via a rigid split coupling. Pipe connection is via DIN flanges.</p>
	<p>The pump is fitted with a 3-phase, fan-cooled asynchronous motor.</p>
	<p>Liquid:  Pumped liquid: Water  Liquid temperature range: -40 .. 120 °C  Selected liquid temperature: 20 °C  Density: 998.2 kg/m<sup>3</sup></p>
	<p>Technical:  Pump speed on which pump data are based: 2924 rpm  Rated flow: 45 m<sup>3</sup>/h  Rated head: 59.4 m  Pump orientation: Vertical  Shaft seal arrangement: Single  Code for shaft seal: HQQE  Approvals: CE,EAC,UKCA,SEPRO  Approvals for drinking water: WRAS,ACS  Curve tolerance: ISO9906:2012 3B</p>
	<p>Materials:  Base: Stainless steel  EN 1.4408  AISI 316  Impeller: Stainless steel  EN 1.4401  AISI 316  Bearing: SIC  Support bearing: Graflon</p>
	<p>Installation:  t max amb: 60 °C  Maximum operating pressure: 16 bar  Max pressure at stated temp: 16 bar / 120 °C  16 bar / -40 °C</p>
	<p>Type of connection: DIN  Size of inlet connection: DN 80  Size of outlet connection: DN 80  Pressure rating for connection: PN 40  Flange size for motor: FF300</p>
	<p>Electrical data:  Motor standard: IEC  Motor type: 160MB  IE Efficiency class: IE3  Rated power - P2: 11 kW  Power (P2) required by pump: 11 kW  Mains frequency: 50 Hz</p>

Qty.	Description
1	<p>Rated voltage: 3 x 380-415D/660-690Y V  Rated current: 20,8-19,8/12,0-11,8 A  Starting current: 660-780 %  Cos phi - power factor: 0.88-0.84  Rated speed: 2940-2950 rpm  Efficiency: IE3 91,2%  Motor efficiency at full load: 91.2-91.2 %  Motor efficiency at 3/4 load: 91.8 %  Motor efficiency at 1/2 load: 91.3 %  Number of poles: 2  Enclosure class (IEC 34-5): 55 Dust/Jetting  Insulation class (IEC 85): F  Motor No: 85U17524</p> <p>Controls:  Frequency converter: NONE</p> <p>Others:  Minimum efficiency index, MEI <math>\geq</math> 0.70  Net weight: 163 kg  Gross weight: 196 kg  Shipping volume: 0.495 m<sup>3</sup>  Country of origin: GB  Custom tariff no.: 84137075</p>

# On request CRN 45-3 A-F-H-E-HQQE 50 Hz

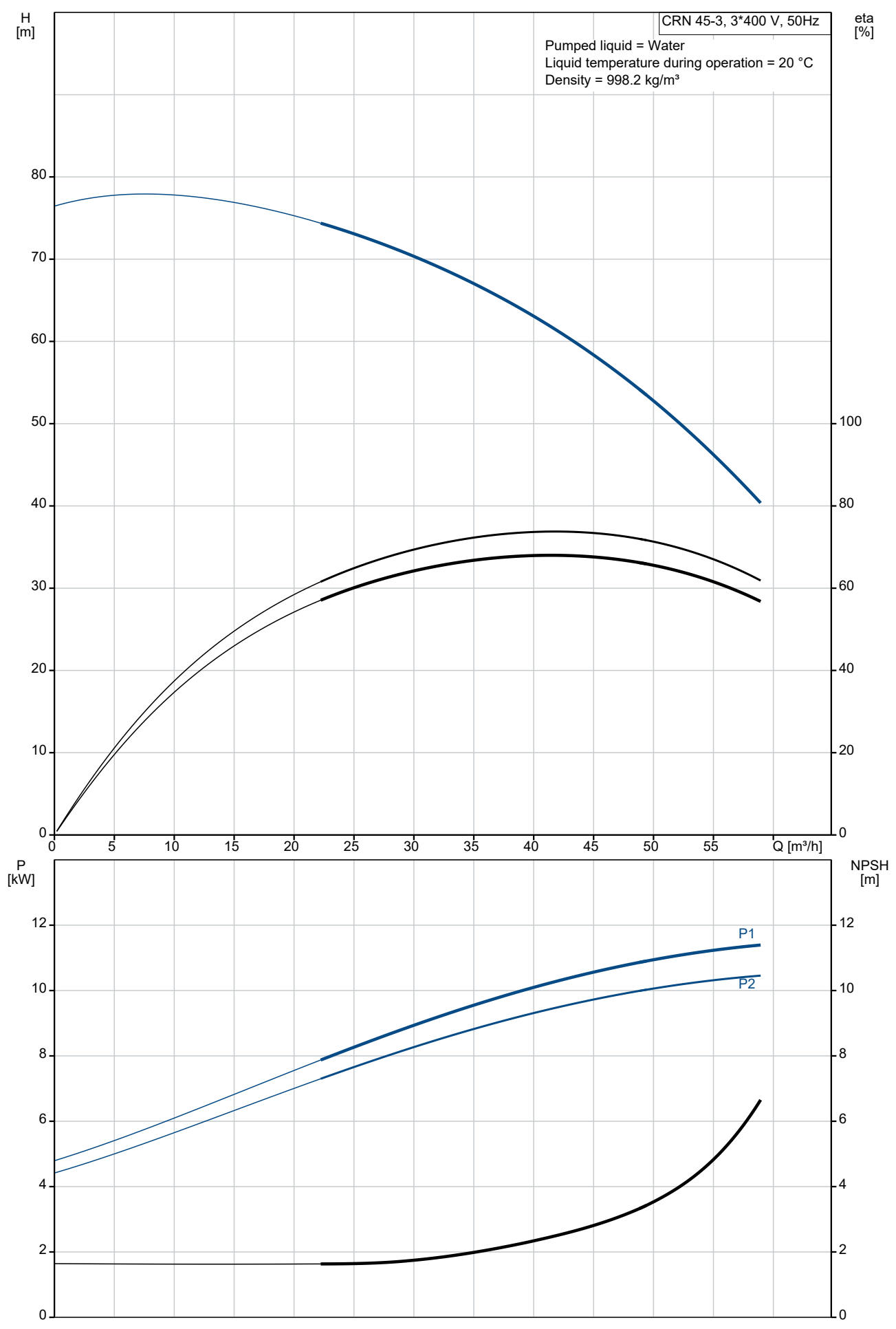

Description	Value
<b>General information:</b>	
Product name:	CRN 45-3 A-F-H-E-HQQE
Product No:	On request
EAN number:	On request
<b>Technical:</b>	
Pump speed on which pump data are based:	2924 rpm
Rated flow:	45 m <sup>3</sup> /h
Rated head:	59.4 m
Maximum head:	77.1 m
Stages:	3
Impellers:	3
Number of reduced-diameter impellers:	0
Low NPSH:	N
Pump orientation:	Vertical
Shaft seal arrangement:	Single
Code for shaft seal:	HQQE
Approvals:	CE,EAC,UKCA,SEPRO
Approvals for drinking water:	WRAS,ACS
Curve tolerance:	ISO9906:2012 3B
Pump version:	A
Model:	B
<b>Materials:</b>	
Base:	Stainless steel
Base:	EN 1.4408
Base:	AISI 316
Impeller:	Stainless steel
Impeller:	EN 1.4401
Impeller:	AISI 316
Material code:	H
Code for rubber:	E
Bearing:	SIC
Support bearing:	Graflon
<b>Installation:</b>	
t max amb:	60 °C
Maximum operating pressure:	16 bar
Max pressure at stated temp:	16 bar / 120 °C
Max pressure at stated temp:	16 bar / -40 °C
Type of connection:	DIN
Size of inlet connection:	DN 80
Size of outlet connection:	DN 80
Pressure rating for connection:	PN 40
Flange size for motor:	FF300
Connect code:	F
<b>Liquid:</b>	
Pumped liquid:	Water
Liquid temperature range:	-40 .. 120 °C
Selected liquid temperature:	20 °C
Density:	998.2 kg/m <sup>3</sup>
<b>Electrical data:</b>	
Motor standard:	IEC
Motor type:	160MB
IE Efficiency class:	IE3
Rated power - P1:	11 kW
Power (P2) required by pump:	11 kW
Mains frequency:	50 Hz
Rated voltage:	3 x 380-415D/660-690Y V
Rated current:	20,8-19,8/12,0-11,8 A
Starting current:	660-780 %
Cos phi - power factor:	0.88-0.84
Rated speed:	2940-2950 rpm
Efficiency:	IE3 91,2%

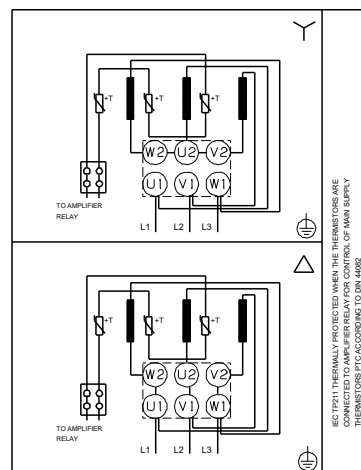
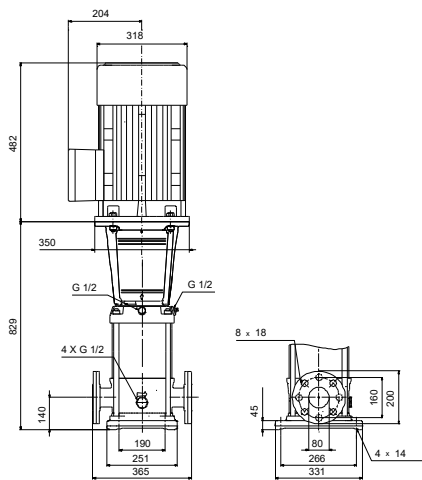
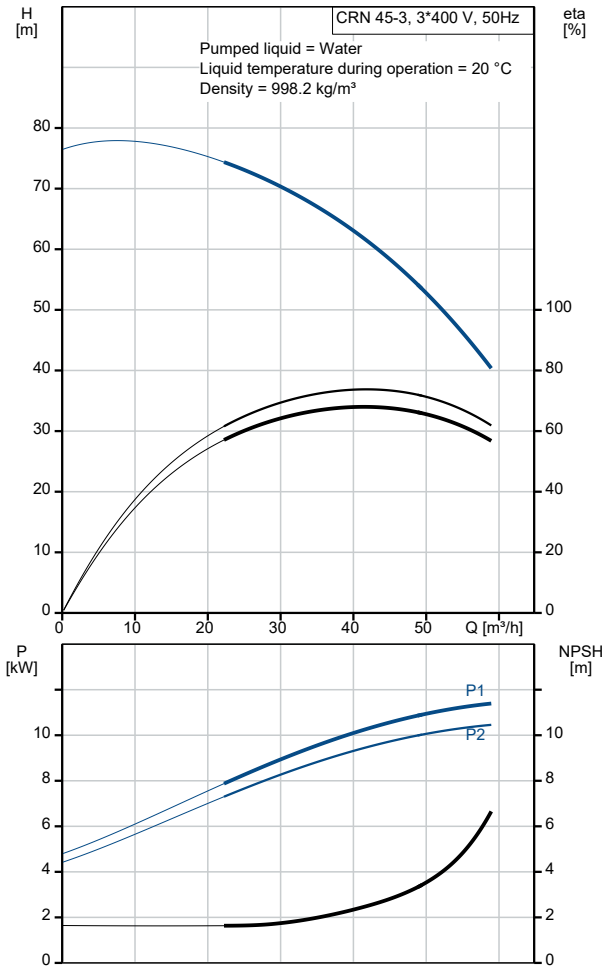

Description	Value
Motor efficiency at full load:	91.2-91.2 %
Motor efficiency at 3/4 load:	91.8 %
Motor efficiency at 1/2 load:	91.3 %
Number of poles:	2
Enclosure class (IEC 34-5):	55 Dust/Jetting
Insulation class (IEC 85):	F
Built-in motor protection:	PTC
Motor No:	85U17524
<b>Controls:</b>	
Frequency converter:	NONE
<b>Others:</b>	
Minimum efficiency index, MEI ≥:	0.70
Net weight:	163 kg
Gross weight:	196 kg
Shipping volume:	0.495 m <sup>3</sup>
Sales region:	Great Britain
Country of origin:	GB
Custom tariff no.:	84137075

# On request CRN 45-3 A-F-H-E-HQQE 50 Hz

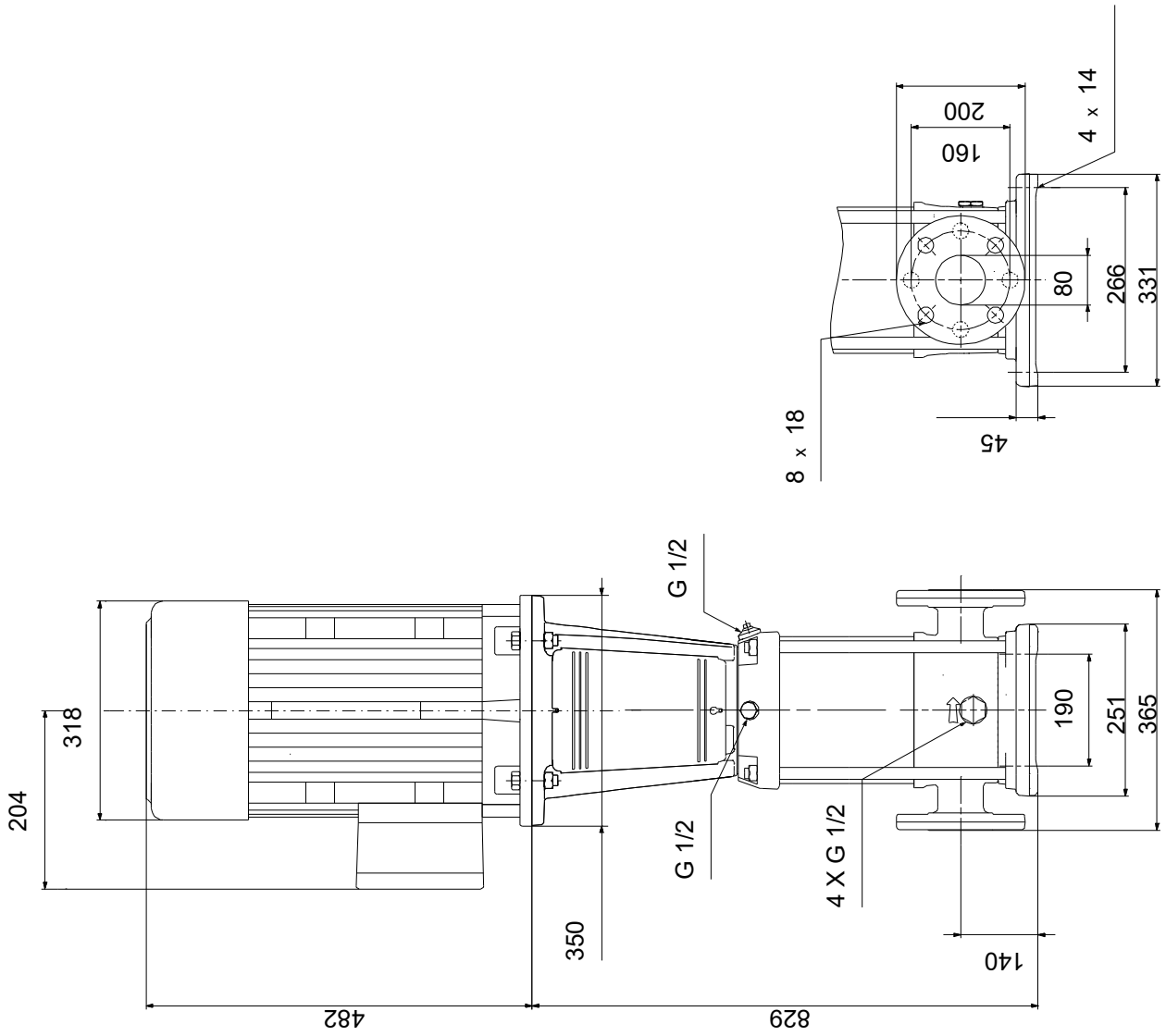

Note! All units are in [mm] unless others are stated.  
Disclaimer: This simplified dimensional drawing does not show all details.

# On request CRN 45-3 A-F-H-E-HQQE 50 Hz

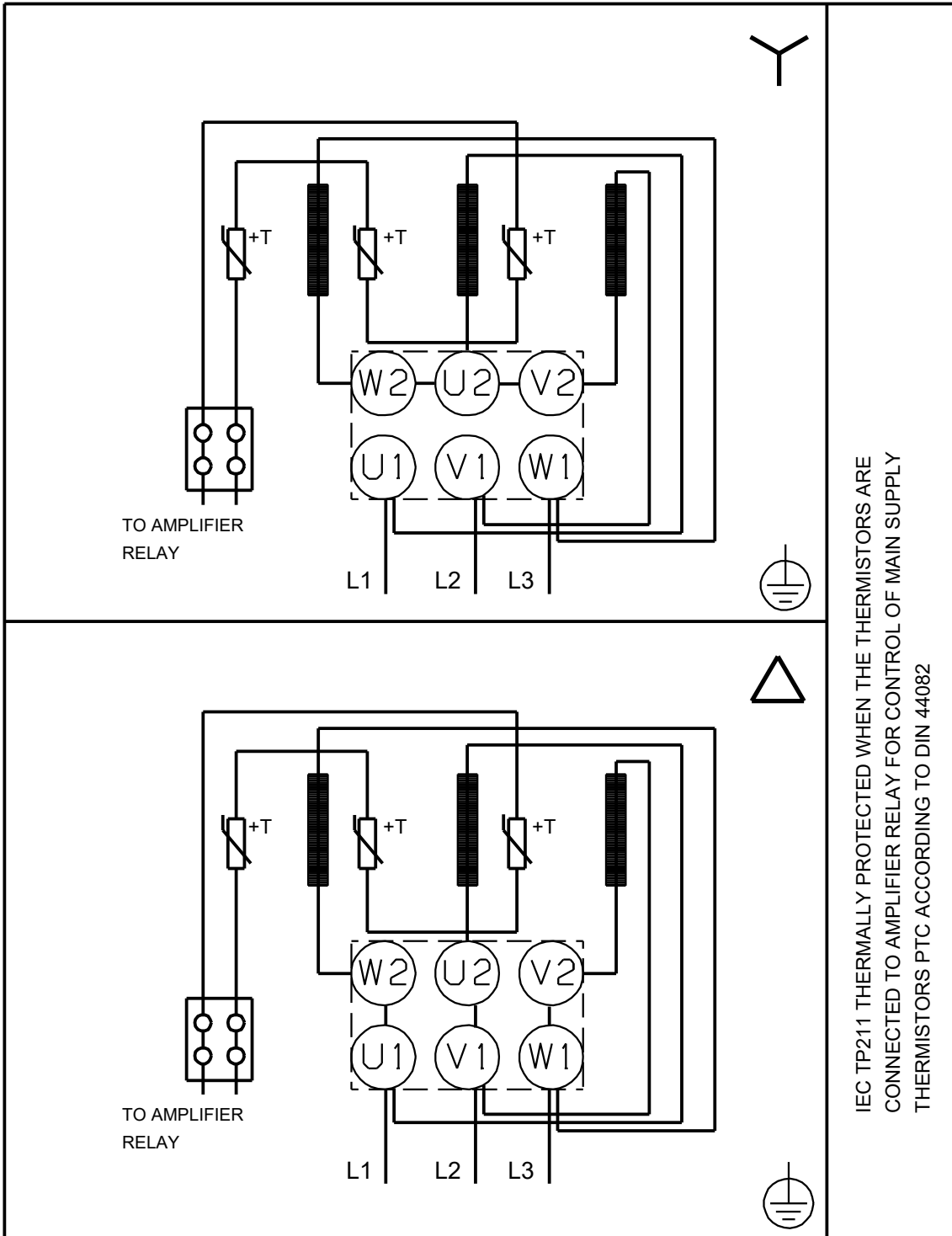

IEC TP211 THERMALLY PROTECTED WHEN THE THERMISTORS ARE  
 CONNECTED TO AMPLIFIER RELAY FOR CONTROL OF MAIN SUPPLY  
 THERMISTORS PTC ACCORDING TO DIN 44082

Note! All units are in [mm] unless others are stated.

