

**Qty. Description**

1 **SEG.40.12.E.EX.2.50B**



**Note! Product picture may differ from actual product**

Product No.: [96878513](#)

Grundfos SEG grinder pumps are non-self-priming, single-stage, centrifugal pumps with horizontal discharge port, specifically designed for pumping wastewater containing discharge from toilets. The pump is equipped with a grinder system that grinds destructible solids into small pieces to lead them through pipes with a relatively small diameter.

SEG grinder pumps are ideal for use in sparsely populated areas, where gravity sewage systems are not available. Examples include villages, farm areas and areas with large terrain-level differences, where a pressurised system has advantages.

The pump is available for two types of installation:

- submerged installation on auto-coupling systems
- submerged installation, free-standing.

The pump is made of wear-resistant materials, such as cast iron and stainless steel.

These materials ensure reliable operation.

The surface of the pump is smooth to prevent dirt and impurities from sticking.

The corrosion-resistant stainless steel clamp is securing the motor to the pump housing and allow the easy service of the pump.

SmartTrim system allows easy adjustment of the impeller clearance to ensure maximum efficiency during the pump lifespan.

The SEG AUTOADAPT version incorporates a controller, sensors and motor protection.

It only needs to be connected to the main supply.

AUTOADAPT eliminates the need for external sensors, switches and cables in the pit, combining all sensors in a single pump that adapts automatically to the dynamic conditions in the pit.

This simplifies installation, commissioning and operation, and increases reliability.

Features of the AUTOADAPT function:

- pump alternation
- alarm relay output
- random start delay in case of general power shutdown
- self-calibration after each pump cycle
- anti-seizing system
- after-run function.

The range is designed to reduce energy consumption and keep downtime costs to a minimum, while maintaining peak performance throughout the lifespan of the system.

The pump is explosion-proof.

### Further product details

This grinder pump is specially designed for pumping effluent and untreated domestic sewage in areas with no sewer system or where gravitation systems are unsuitable.

The pump is designed for transfer of domestic and municipal wastewater:

- in sparsely populated areas

Qty.	Description
------	-------------

1

- in small villages and farms
- in areas of difficult topography
- in areas with high groundwater

The pump can also remove industrial wastewater containing fibres in industrial applications, such as washing plants.

### Pump

The pump is primarily made of cast iron with surface treatment of powder coating: black NCS9000N/RAL 9005, gloss 30, thickness 100 µ.

The pump features a patented grinder system, ensuring extremely high efficiency and reliable operation. Quick and easy dismantling for replacement of wear parts. No special tools are required.



A stainless-steel clamp connection between motor and pump housing ensures easy inspection and service of the impeller and shaft seal.

The shaft seal consists of a cartridge seal that ensures a reliable sealing between pumped liquid and motor.

- Primary seal: silicon carbide/silicon carbide (SiC/SiC) mechanical shaft seal
- Secondary seal: lip seal

In connection with service, the mechanical shaft seal and the lip seal are supplied as one unit ready for fitting.



This pump is equipped with the unique SmartTrim system that enables you to easily restore the factory-set impeller clearance and maintain peak pumping efficiency.

To do this, remove the cutter head and adjust the SmartTrim nut on the impeller.

This can be done on site without dismantling the pump and without using special tools.

The pump has been tested and approved by VDE. Furthermore, the pump is approved for installation in explosive atmospheres and holds the following examination certificate:

- KEMA 06ATEX0127X
- IECEx KEM 06 0028X

Both certificates have been issued by KEMA according to the ATEX directive (94/9/EC).

Note: Explosion-proof pumps must always be fully submerged.

### Motor

The motor is a watertight, totally encapsulated motor, supplied with a 10 m power cable.

The stainless-steel plug is fastened with a union nut.

This nut and O-rings provide sealing against ingress of the liquid.

The plug is polyurethane-embedded, ensuring a watertight and durable seal around the leads of the cable.

This prevents the ingress of water into the motor through the cable in case of cable breakage or adverse handling in connection with installation or service.

The motor construction is compact with a short shaft. This reduces vibrations, resulting in an increased efficiency and life of the shaft seal and ball bearings. The motor has two thermal switches in the motor windings to protect the motor against overheating.

### AUTOADAPT

This AUTOADAPT pump will adapt when it is placed in the pit and can detect the presence of other pumps.

**Qty. Description**

1	<p>Up to four pumps will automatically calibrate their start/stop levels and fall into a pump alternation routine, ensuring optimum performance at all times.</p> <p>No need for communication between the pumps.</p> <p>The AUTOADAPT pump includes the following:</p> <ul style="list-style-type: none"> <li>- Built-in level and dry-running sensors</li> <li>- Built-in motor protection</li> <li>- Alarm relay output. NC and NO are available and can be used as required, for example for acoustic or visual alarms.</li> <li>- Random start delay in case of general power shutdown</li> <li>- Self-calibration after each pump cycle</li> <li>- Anti-seizing function. The pump starts at programmed intervals to prevent the impeller from seizing up.</li> <li>- After-run function. At programmed intervals, the pump sets start/stop level below the pump housing to drain foam in the pit.</li> <li>- Phase sequence detection. The pump does not start unless the phase sequence is correct.</li> </ul> <p>The AUTOADAPT pumps are intelligent, standalone solutions that can be easily integrated into SCADA systems or remote monitoring systems for pumping stations. Using power line communication (mains-borne signaling), you can add a Grundfos communication interface box for complete information or simply use the built-in alarm relay.</p> <p>Controls:</p> <p>Moisture sensor: without moisture sensors</p> <p>AUTOADAPT: YES</p> <p>Liquid:</p> <p>Liquid temperature range: 0 .. 40 °C</p> <p>Density: 998.2 kg/m<sup>3</sup></p> <p>Technical:</p> <p>Type of impeller: Grinder system</p> <p>Primary shaft seal: SIC/SIC</p> <p>Curve tolerance: ISO9906:2012 3B2</p> <p>Materials:</p> <p>Pump housing: Cast iron EN-GJL-200</p> <p>Impeller: Cast iron EN-GJL-200</p> <p>Installation:</p> <p>t max amb: 40 °C</p> <p>Maximum operating pressure: 6 bar</p> <p>Flange standard: DIN</p> <p>Pipework connection: DN40/50</p> <p>Pump outlet: DN 40</p> <p>Pressure rating: PN 10</p> <p>Maximum installation depth: 10 m</p> <p>Auto-coupling: 96076063</p> <p>Electrical data:</p> <p>Power input - P1: 1.8 kW</p> <p>Rated power - P2: 1.2 kW</p> <p>Mains frequency: 50 Hz</p> <p>Rated voltage: 3 x 400-415 V</p> <p>Voltage tolerance: +6/-10 %</p> <p>Max starts per. hour: 30</p> <p>Rated current: 3.2/3.2 A</p> <p>Starting current: 21 A</p>
---	---



Company name:

Created by:

Phone:

Date:

08/08/2022

**Qty. Description**

1	Rated current at no load:	1.9 A
	Cos phi - power factor:	0.81
	Cos phi - p.f. at 3/4 load:	0.72
	Cos phi - p.f. at 1/2 load:	0.58
	Rated speed:	2750 rpm
	Moment of inertia:	0.0038 kg m <sup>2</sup>
	Motor efficiency at full load:	73 %
	Motor efficiency at 3/4 load:	71 %
	Motor efficiency at 1/2 load:	66 %
	Number of poles:	2
	Start. method:	direct-on-line
	Enclosure class (IEC 34-5):	IP68
	Insulation class (IEC 85):	F
	Explosion proof:	yes
	Explosion protection standard:	EN60079
	Length of cable:	10 m
	Cable type:	LYNIFLEX
	Type of cable plug:	No plug
	Others:	
	Net weight:	50 kg
	Danish VVS No.:	391344431
	Country of origin:	HU
	Custom tariff no.:	84137021

## 96878513 SEG.40.12.E.EX.2.50B 50 Hz

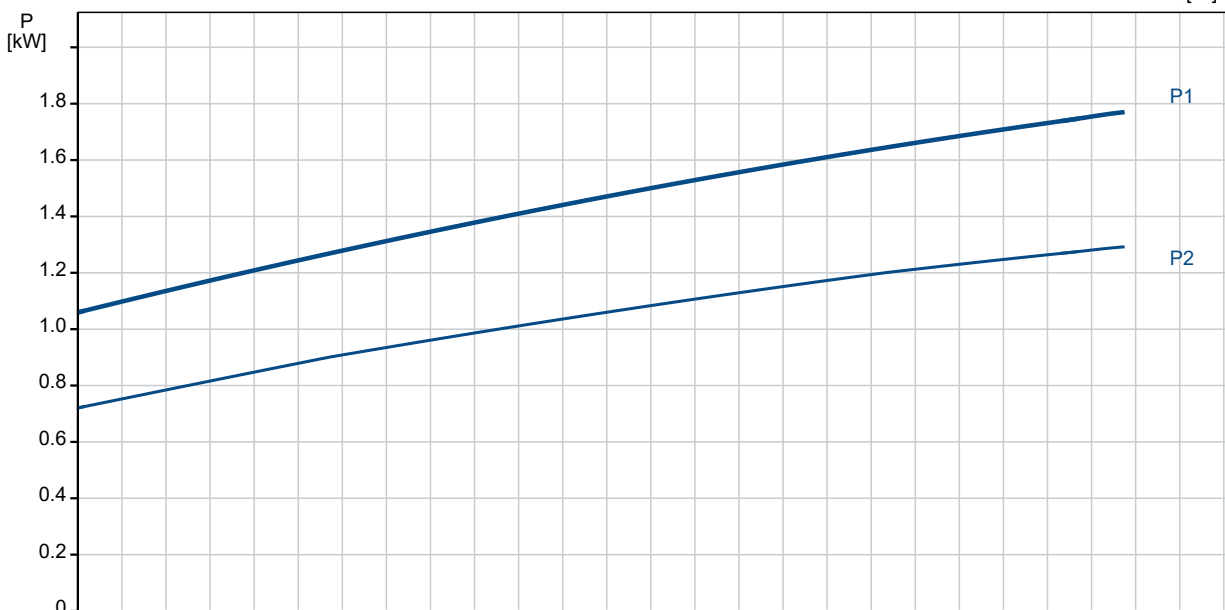
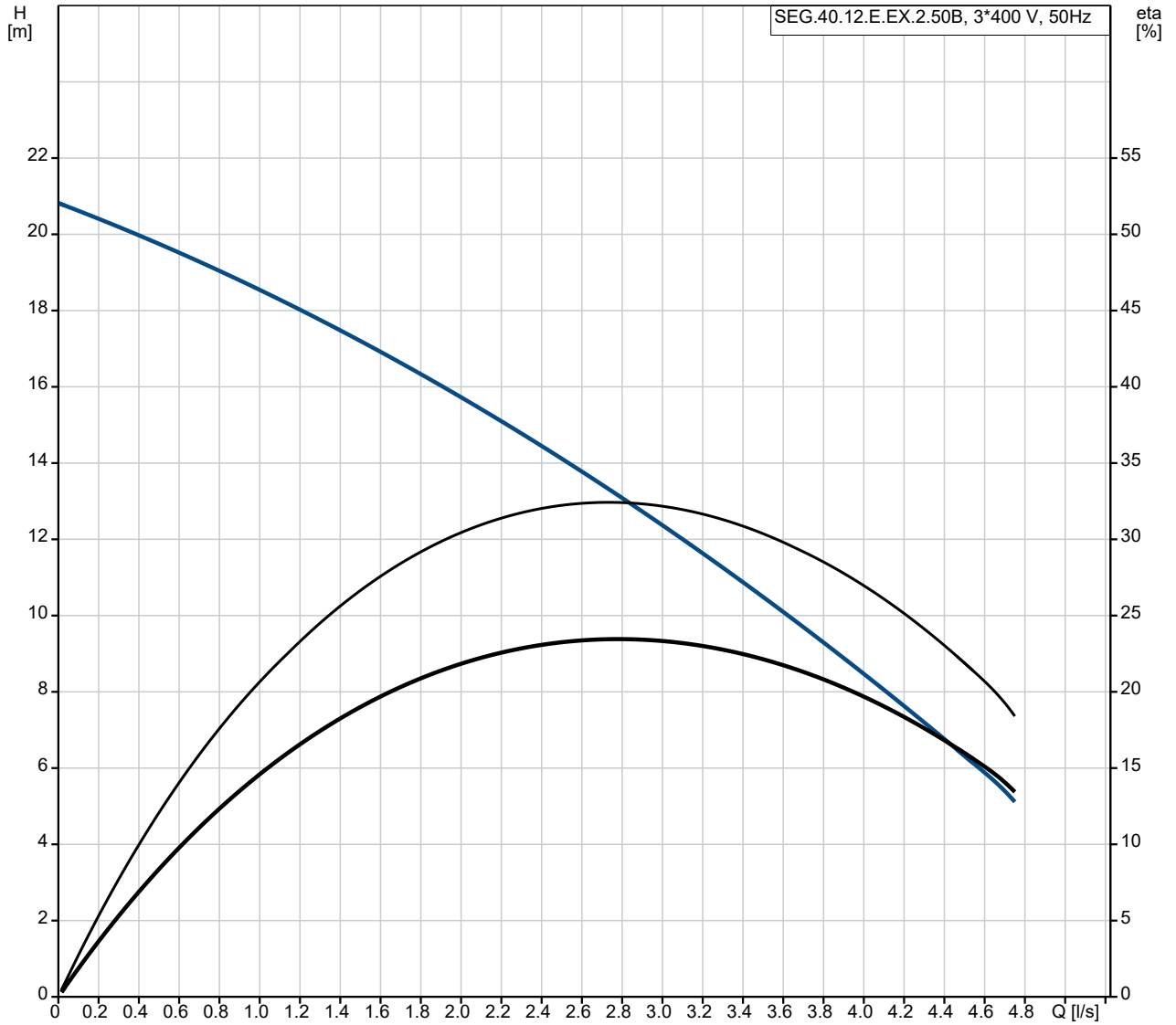

Description	Value
<b>General information:</b>	
Product name:	SEG.40.12.E.EX.2.50B
Product No:	96878513
EAN number:	5700312551263
<b>Technical:</b>	
Max flow:	4.75 l/s
Max flow:	4.75 l/s
Head max:	20.7 m
Type of impeller:	Grinder system
Primary shaft seal:	SIC/SIC
Curve tolerance:	ISO9906:2012 3B2
<b>Materials:</b>	
Pump housing:	Cast iron
Pump housing:	EN-GJL-200
Impeller:	Cast iron
Impeller:	EN-GJL-200
<b>Installation:</b>	
t max amb:	40 °C
Maximum operating pressure:	6 bar
Flange standard:	DIN
Pipework connection:	DN40/50
Pump outlet:	DN 40
Pressure rating:	PN 10
Maximum installation depth:	10 m
Inst dry/wet:	SUBMERGED
Auto-coupling:	96076063
<b>Liquid:</b>	
Liquid temperature range:	0 .. 40 °C
Density:	998.2 kg/m <sup>3</sup>
<b>Electrical data:</b>	
Power input - P1:	1.8 kW
Rated power - P2:	1.2 kW
Mains frequency:	50 Hz
Rated voltage:	3 x 400-415 V
Voltage tolerance:	+6/-10 %
Max starts per. hour:	30
Rated current:	3.2/3.2 A
Starting current:	21 A
Rated current at no load:	1.9 A
Cos phi - power factor:	0.81
Cos phi - p.f. at 3/4 load:	0.72
Cos phi - p.f. at 1/2 load:	0.58
Rated speed:	2750 rpm
Moment of inertia:	0.0038 kg m <sup>2</sup>
Motor efficiency at full load:	73 %
Motor efficiency at 3/4 load:	71 %
Motor efficiency at 1/2 load:	66 %
Number of poles:	2
Start. method:	direct-on-line
Enclosure class (IEC 34-5):	IP68
Insulation class (IEC 85):	F
Explosion proof:	yes
Explosion protection standard:	EN60079
Built-in motor protection:	THERMAL SWITCH
Thermal protec:	internal
Length of cable:	10 m
Cable type:	LYNIFLEX
Type of cable plug:	No plug

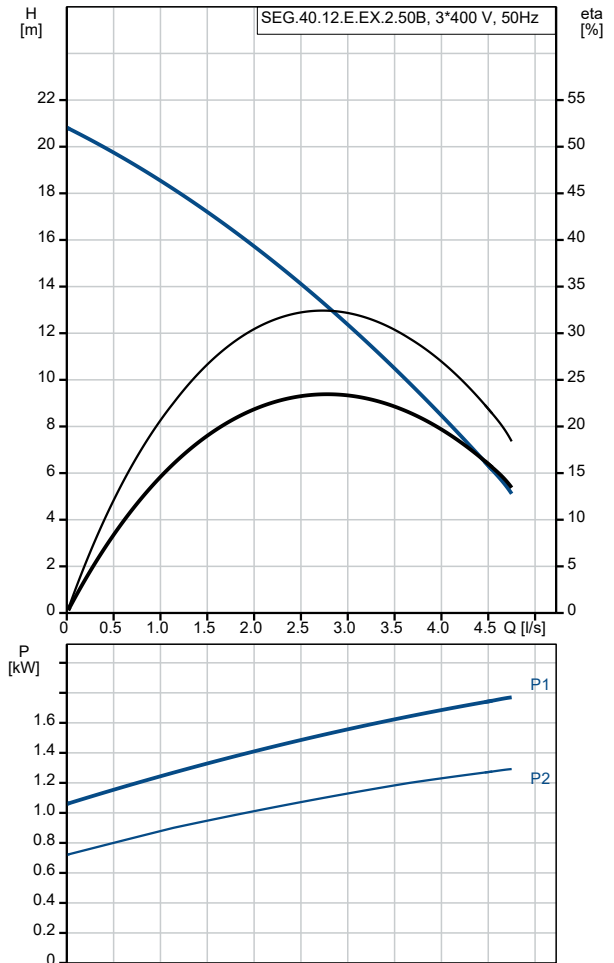



Company name:

Created by:

Phone:

Date:

08/08/2022

Description	Value
<b>Controls:</b>	
Control box:	not included
Additional I/O:	Build in
Moisture sensor:	without moisture sensors
AUTOADAPT:	YES
<b>Others:</b>	
Net weight:	50 kg
Danish VVS No.:	391344431
Country of origin:	HU
Custom tariff no.:	84137021

## 96878513 SEG.40.12.E.EX.2.50B 50 Hz

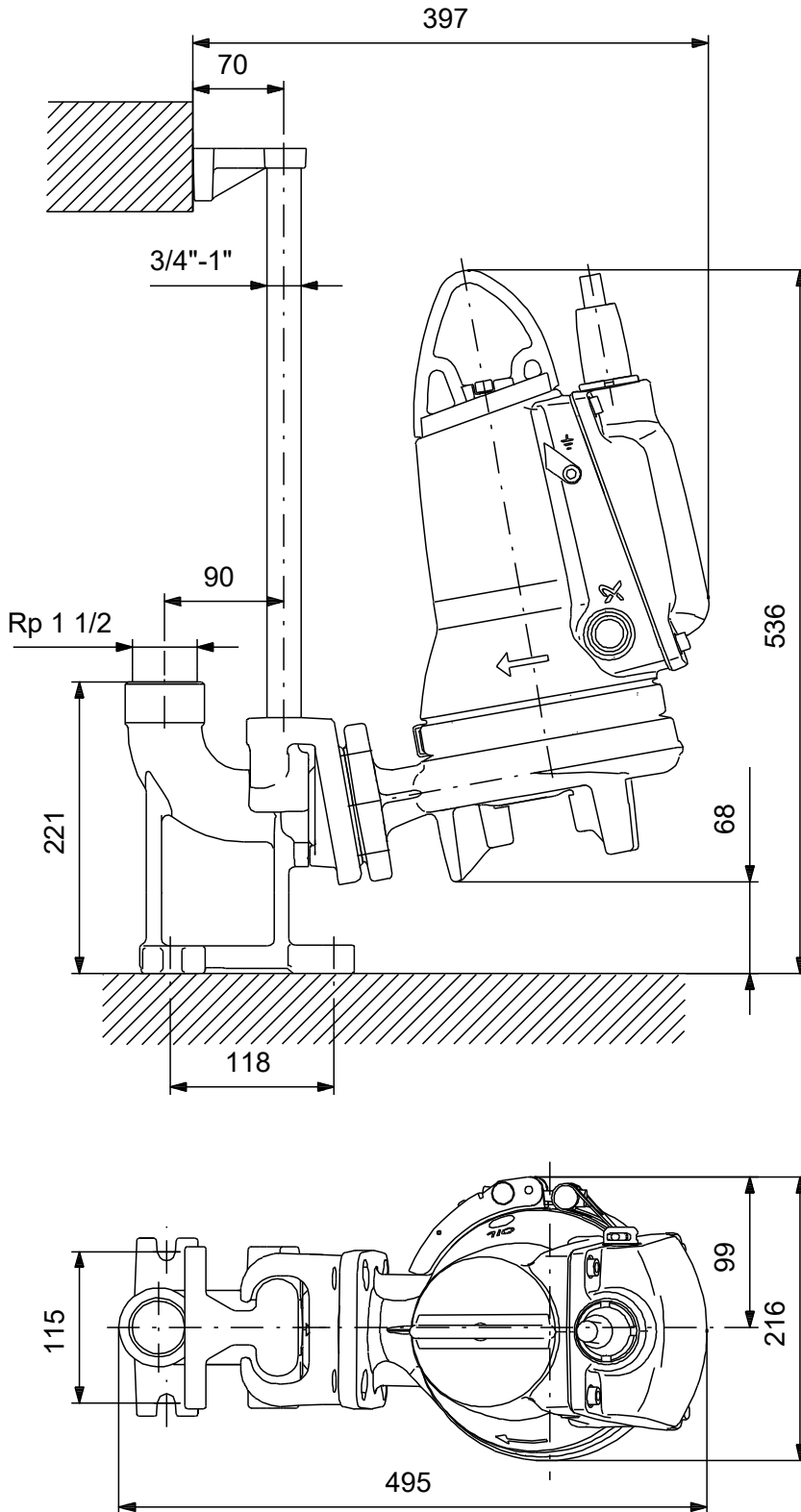

Note! All units are in [mm] unless others are stated.  
Disclaimer: This simplified dimensional drawing does not show all details.

## 96878513 SEG.40.12.E.EX.2.50B 50 Hz

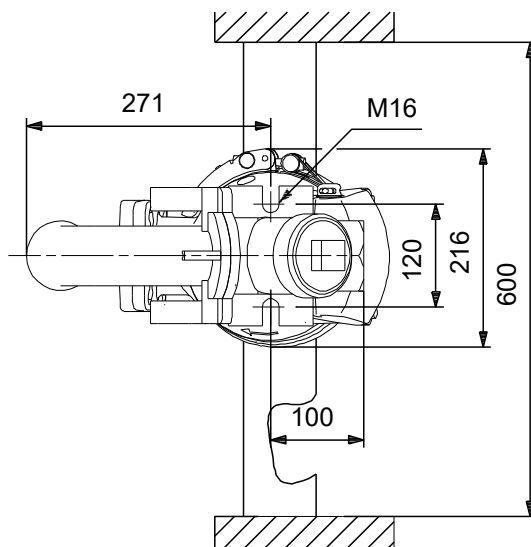
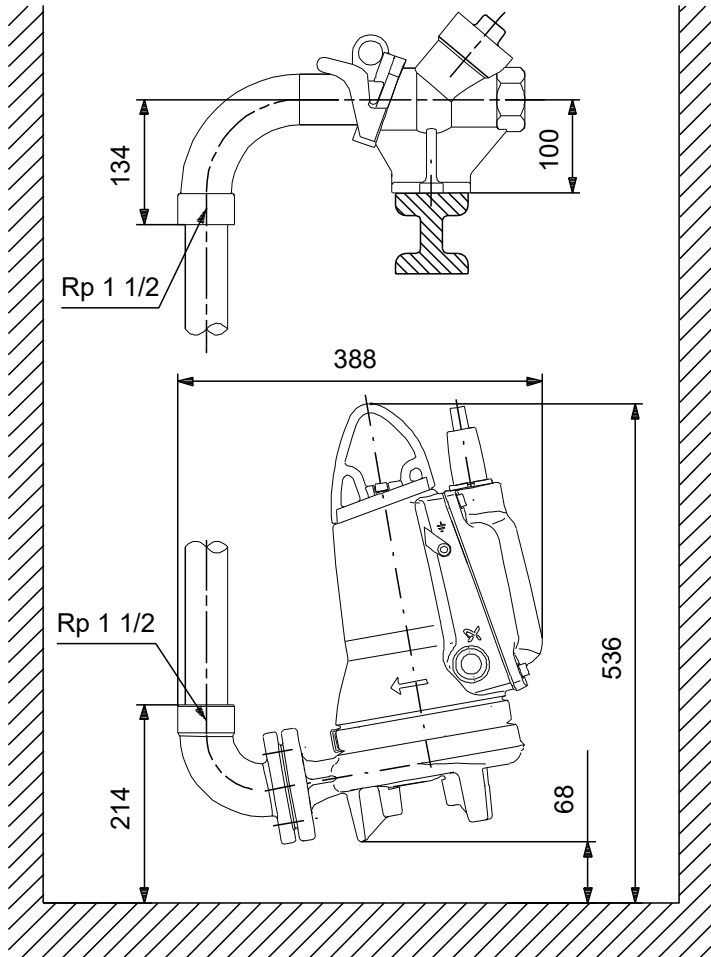

Note! All units are in [mm] unless others are stated.  
Disclaimer: This simplified dimensional drawing does not show all details.

## 96878513 SEG.40.12.E.EX.2.50B 50 Hz

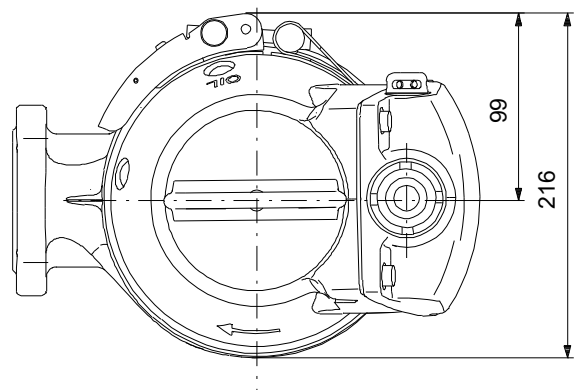
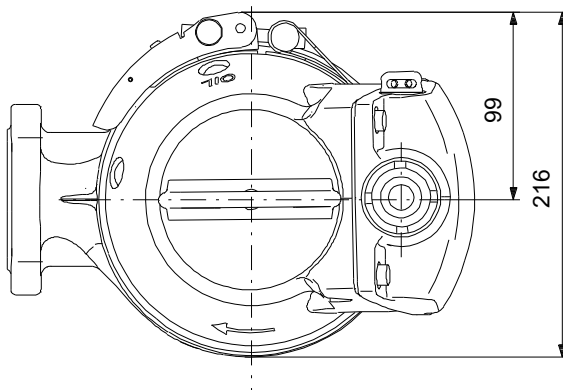
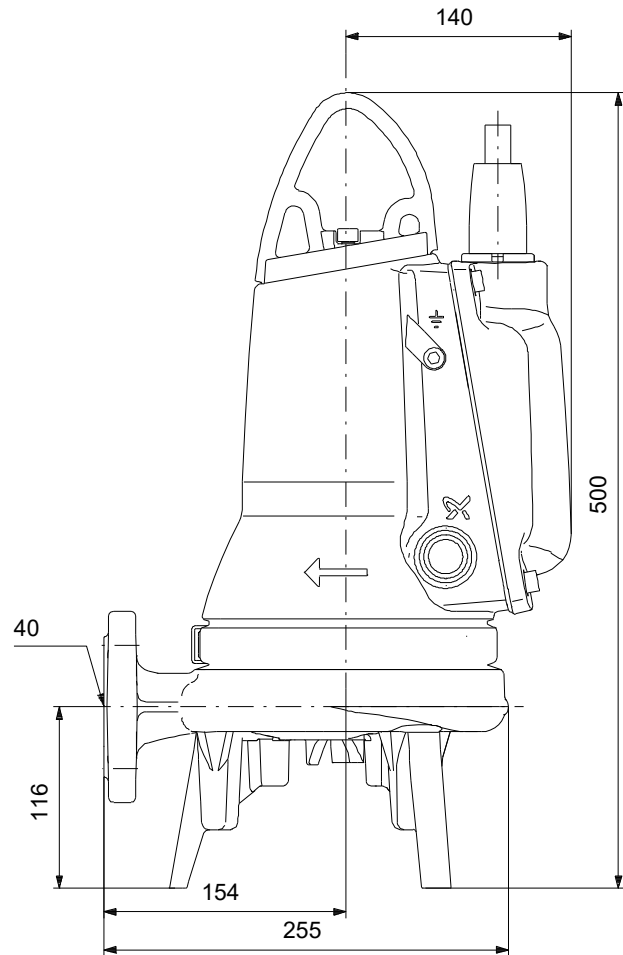
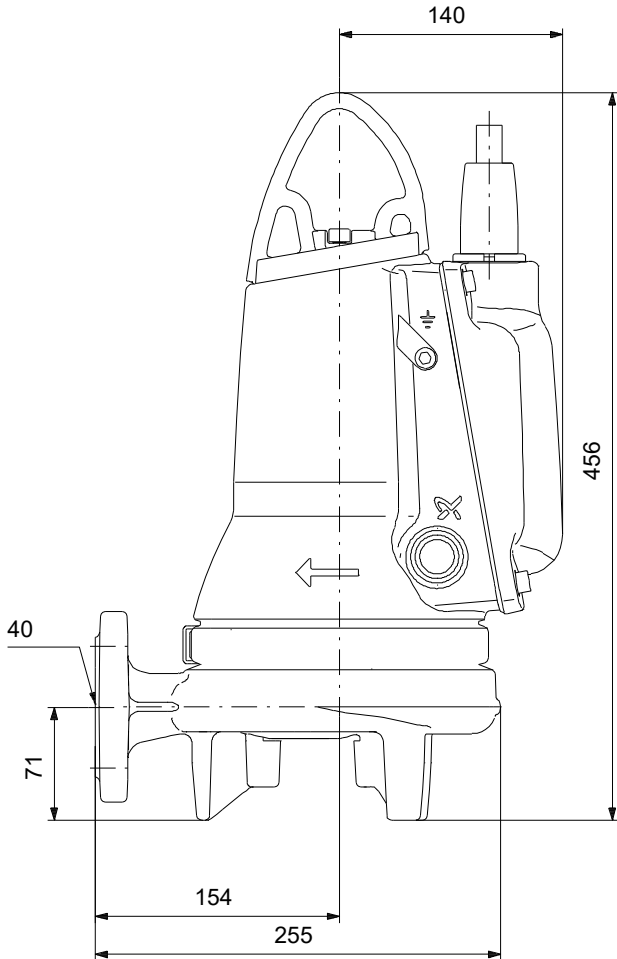

Note! All units are in [mm] unless others are stated.  
Disclaimer: This simplified dimensional drawing does not show all details.

## 96878513 SEG.40.12.E.EX.2.50B 50 Hz

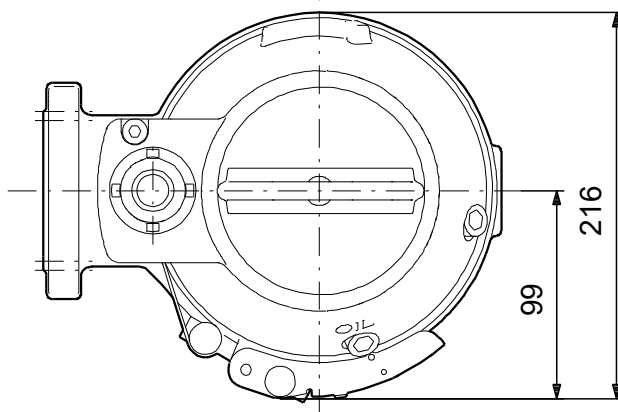
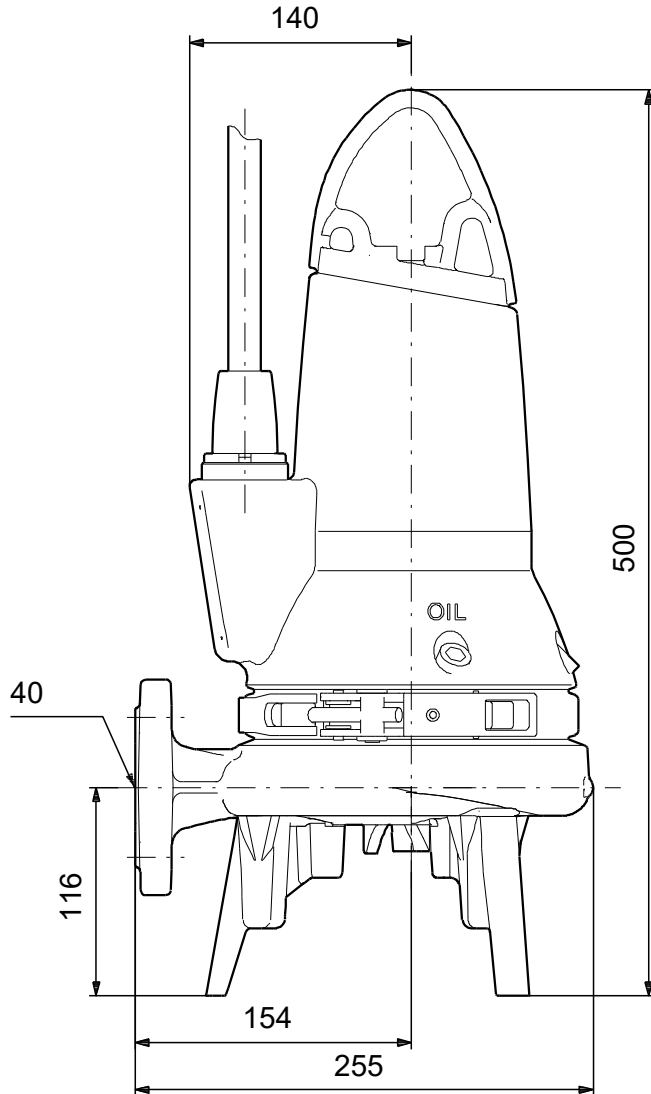

Note! All units are in [mm] unless others are stated.  
Disclaimer: This simplified dimensional drawing does not show all details.

96878513 SEG.40.12.E.EX.2.50B 50 Hz

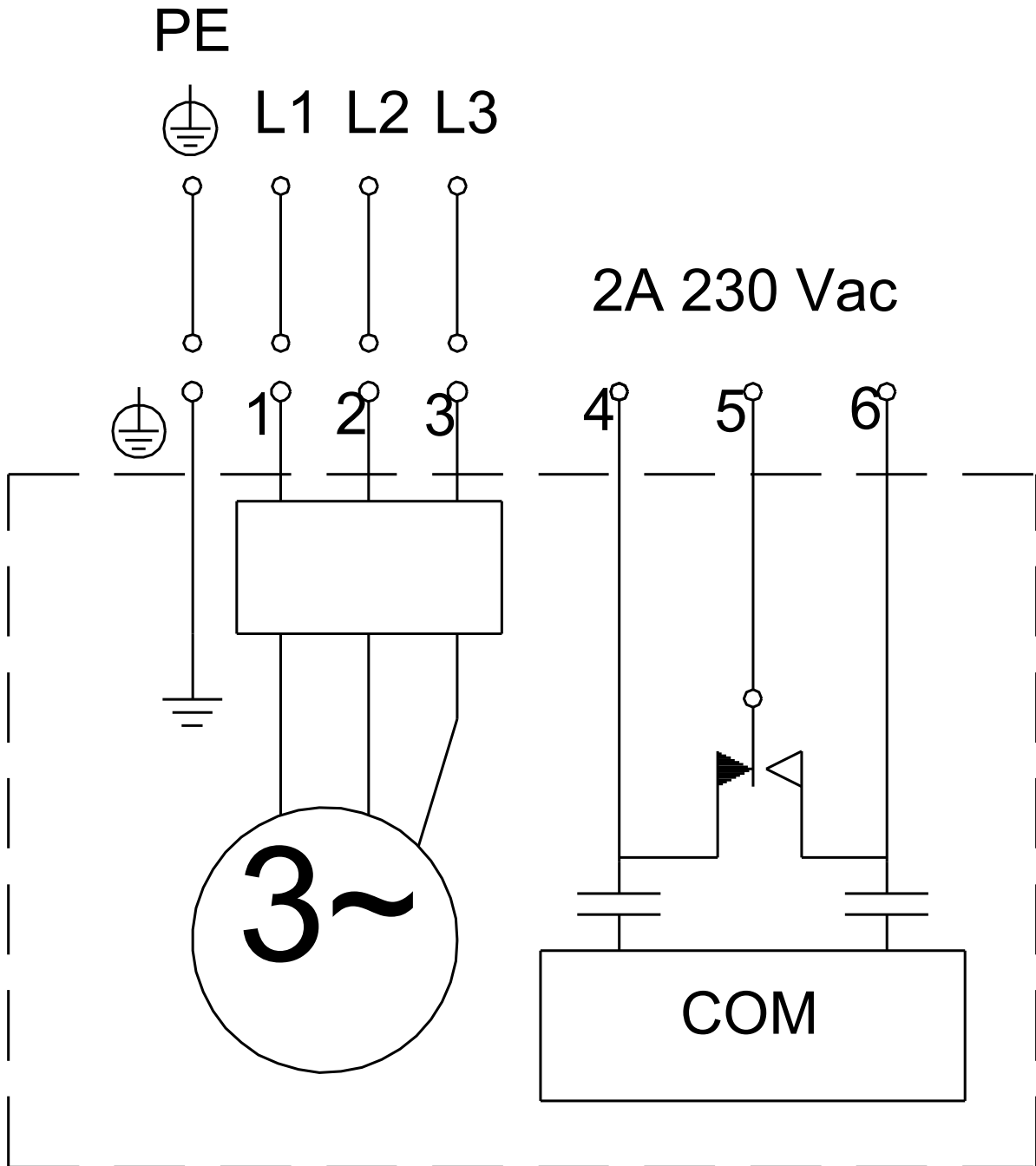

Note! All units are in [mm] unless others are stated.