

Qty.	Description
1	TPE3 40-80 S-A-F-I-BQQE-CAB
	
	<p>Note! Product picture may differ from actual product</p>
	<p>Product No.: On request</p>
	<p>Single-stage, close-coupled, volute pump with in-line suction and discharge ports of identical diameter. The pump is of the top-pull-out design, i.e. the power head (motor, pump head and impeller) can be removed for maintenance or service while the pump housing remains in the pipework.</p>
	<p>The shaft seal is according to EN 12756. Pipework connection is via PN 6/10 DIN flanges (EN 1092-2 and ISO 7005-2).</p>
	<p>The pump is fitted with a fan-cooled, permanent-magnet synchronous motor. The motor efficiency is classified as IE5 in accordance with IEC 60034-30-2.</p>
	<p>The motor includes a frequency converter and PI controller in the motor terminal box. This enables continuously variable control of the motor speed, which again enables adaptation of the performance to a given requirement.</p>
	<p>The pump is fitted with a combined temperature- and differential pressure sensor.</p>
	<p>Controls:</p>
	<p>Frequency converter: Built-in</p>
	<p>Liquid:</p>
	<p>Pumped liquid: Water</p>
	<p>Liquid temperature range: -25 .. 120 °C</p>
	<p>Selected liquid temperature: 20 °C</p>
	<p>Density: 998.2 kg/m³</p>
	<p>Technical:</p>
	<p>Pump speed on which pump data are based: 2970 rpm</p>
	<p>Rated flow: 12.3 m³/h</p>
	<p>Rated head: 5.4 m</p>
	<p>Actual impeller diameter: 74 mm</p>
	<p>Code for shaft seal: BQQE</p>
	<p>Curve tolerance: ISO9906:2012 3B2</p>
	<p>Materials:</p>
	<p>Pump housing: Stainless steel</p>
	<p>EN 1.4308</p>
	<p>ASTM CF8</p>
	<p>Impeller: Composite</p>
	<p>PES+30% GF</p>
	<p>Installation:</p>
	<p>Range of ambient temperature: -20 .. 50 °C</p>
	<p>Maximum operating pressure: 10 bar</p>
	<p>Max pressure at stated temp: 10 bar / 120 °C</p>
	<p>Type of connection: DIN</p>
	<p>Size of connection: DN 40</p>
	<p>Pressure rating for connection: PN 6/10</p>
	<p>Port-to-port length: 250 mm</p>
	<p>Flange size for motor: 56C</p>
	<p>Electrical data:</p>
	<p>Motor type: 71A</p>
	<p>IE Efficiency class: IE5</p>
	<p>Rated power - P2: 0.25 kW</p>
	<p>Mains frequency: 50 / 60 Hz</p>
	<p>Rated voltage: 1 x 200-240 V</p>

Qty.	Description
1	<p>Rated current: 1.75-1.50 A Cos phi - power factor: 0.95 Rated speed: 360-4000 rpm Efficiency: 81.1% Motor efficiency at full load: 81.1 % Enclosure class (IEC 34-5): IP55 Insulation class (IEC 85): F Motor No: 99137982</p> <p>Others: Minimum efficiency index, MEI ≥: 0.70 Net weight: 23 kg Gross weight: 30.2 kg Shipping volume: 0.104 m³ Danish VVS No.: 382141080 Country of origin: HU Custom tariff no.: 84137051</p>

Description	Value
General information:	
Product name:	TPE3 40-80 S-A-F-I-BQQE-CAB
Product No:	On request
EAN number:	On request
Technical:	
Pump speed on which pump data are based:	2970 rpm
Rated flow:	12.3 m ³ /h
Rated head:	5.4 m
Maximum head:	80 dm
Actual impeller diameter:	74 mm
Code for shaft seal:	BQQE
Curve tolerance:	ISO9906:2012 3B2
Pump version:	A
Materials:	
Pump housing:	Stainless steel
Pump housing:	EN 1.4308
Pump housing:	ASTM CF8
Impeller:	Composite
Impeller:	PES+30% GF
Material code:	I
Installation:	
Range of ambient temperature:	-20 .. 50 °C
Maximum operating pressure:	10 bar
Max pressure at stated temp:	10 bar / 120 °C
Type of connection:	DIN
Size of connection:	DN 40
Pressure rating for connection:	PN 6/10
Port-to-port length:	250 mm
Flange size for motor:	56C
Connect code:	F
Liquid:	
Pumped liquid:	Water
Liquid temperature range:	-25 .. 120 °C
Selected liquid temperature:	20 °C
Density:	998.2 kg/m ³
Electrical data:	
Motor type:	71A
IE Efficiency class:	IE5
Rated power - P2:	0.25 kW
Mains frequency:	50 / 60 Hz
Rated voltage:	1 x 200-240 V
Rated current:	1.75-1.50 A
Cos phi - power factor:	0.95
Rated speed:	360-4000 rpm
Efficiency:	81.1%
Motor efficiency at full load:	81.1 %
Enclosure class (IEC 34-5):	IP55
Insulation class (IEC 85):	F
Built-in motor protection:	ELEC
Motor No:	99137982
Controls:	
Control panel:	HMI300 - Graphical
Function Module:	FM300 - Advanced
Frequency converter:	Built-in
Others:	
Minimum efficiency index, MEI ≥:	0.70
Net weight:	23 kg
Gross weight:	30.2 kg
Shipping volume:	0.104 m ³
Config. file no:	98481320
Danish VVS No.:	382141080
Country of origin:	HU

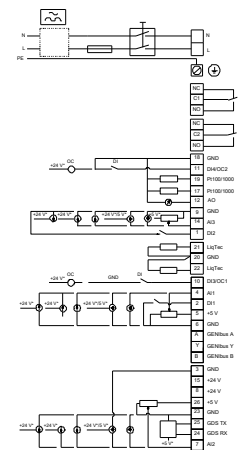
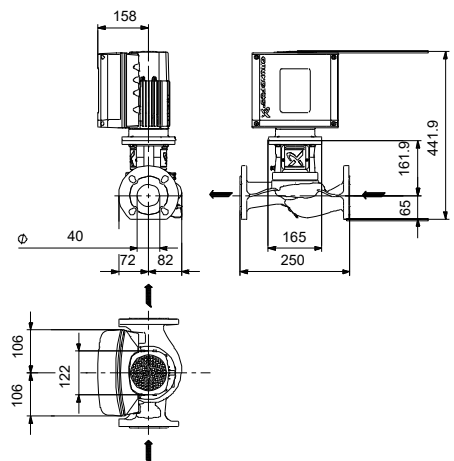
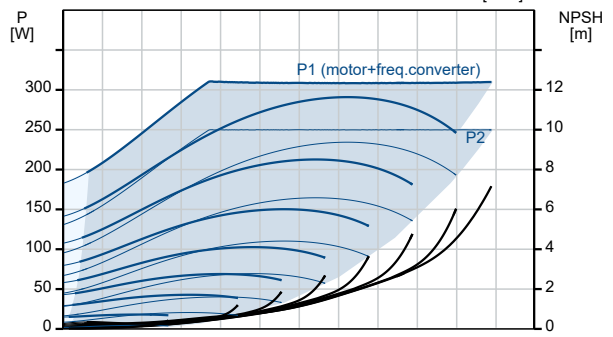
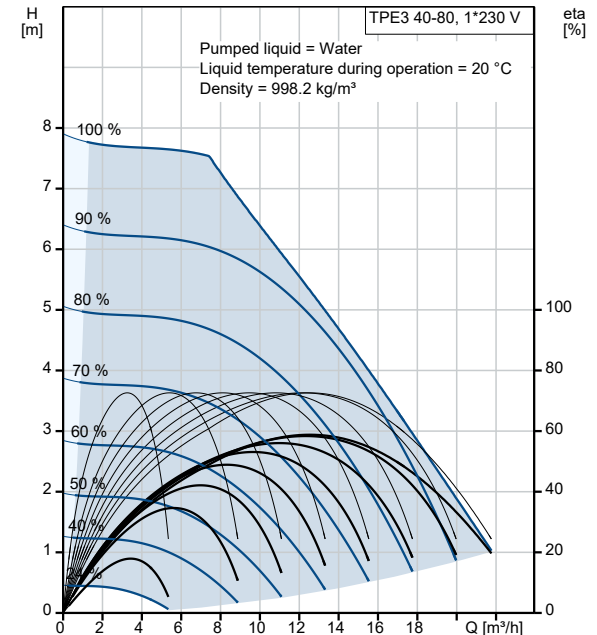

Description**Value**

Custom tariff no.:

84137051

On request TPE3 40-80 S-A-F-I-BQQE-CAB

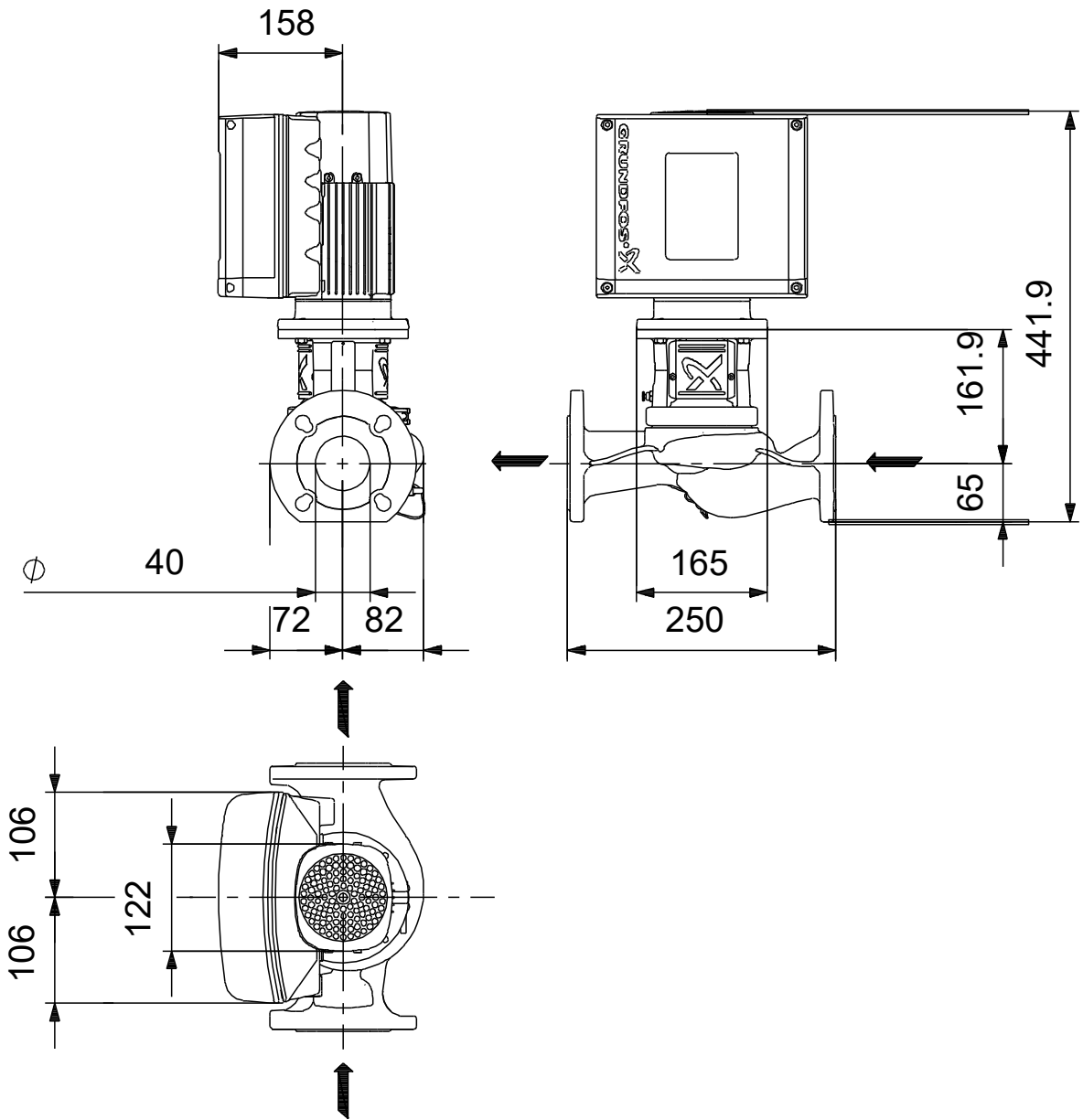

Note! All units are in [mm] unless others are stated.
Disclaimer: This simplified dimensional drawing does not show all details.

