

Qty.	Description
1	<b>MTR 45-2/2 A-F-A-HUUV</b>
	
	Product No.: On request
	<p>Multistage, immersible, self-priming, centrifugal pump for vertical installation in tanks etc.            The pump head and base are in cast iron – all other wetted parts are in stainless steel. The pump has the following characteristics:</p>
	<ul style="list-style-type: none"> <li>• Dimensions according to DIN 5440.</li> <li>• Impellers, intermediate chambers and spline shaft are made of Stainless steel.</li> <li>• Mechanical shaft seal according to EN 12756.</li> <li>• Power transmission via sintered metal split coupling.</li> </ul>
	<p>A cartridge shaft seal ensures high reliability, safe handling, and easy access and service. The pump is fitted with a 3-phase, fan-cooled asynchronous motor.</p>
	<b>Controls:</b>
	Frequency converter: NONE
	<b>Liquid:</b>
	Pumped liquid: Water
	Liquid temperature range: -10 .. 90 °C
	Selected liquid temperature: 20 °C
	Density: 998.2 kg/m <sup>3</sup>
	<b>Technical:</b>
	Pump speed on which pump data are based: 2919 rpm
	Rated flow: 750 l/min
	Rated head: 36.6 m
	Chambers: 2
	Drainage back to tank: N
	Pump orientation: Vertical
	Code for shaft seal: HUUV
	Approvals: CE,EAC
	Curve tolerance: ISO9906:2012 3B
	<b>Materials:</b>
	Pump head: Cast iron EN 1561 EN-GJL-200 ASTM A48-25B
	Impeller: Stainless steel EN 1.4301 AISI 304
	<b>Installation:</b>
	t max amb: 60 °C
	Maximum operating pressure: 25 bar
	Max pressure at stated temp: 25 bar / 90 °C
	Type of connection: DIN
	Size of outlet connection: DN 80
	Immersion depth: 244 mm
	Pressure rating for connection: PN 40
	Flange size for motor: FF265
	<b>Electrical data:</b>
	Motor standard: IEC
	Motor type: 132SB
	IE Efficiency class: IE3

Qty.	Description																																																		
1	<table> <tr> <td>Rated power - P2:</td> <td>7.5 kW</td> </tr> <tr> <td>Mains frequency:</td> <td>50 Hz</td> </tr> <tr> <td>Suitable for 50/60 Hz:</td> <td>N</td> </tr> <tr> <td>Rated voltage:</td> <td>3 x 380-415D/660-690Y V</td> </tr> <tr> <td>Rated current:</td> <td>14,4-14,0/8,30-8,10 A</td> </tr> <tr> <td>Starting current:</td> <td>780-910 %</td> </tr> <tr> <td>Cos phi - power factor:</td> <td>0.88-0.82</td> </tr> <tr> <td>Rated speed:</td> <td>2910-2920 rpm</td> </tr> <tr> <td>Efficiency:</td> <td>IE3 90,1%</td> </tr> <tr> <td>Motor efficiency at full load:</td> <td>90.1-90.4 %</td> </tr> <tr> <td>Motor efficiency at 3/4 load:</td> <td>90.8 %</td> </tr> <tr> <td>Motor efficiency at 1/2 load:</td> <td>90.8 %</td> </tr> <tr> <td>Number of poles:</td> <td>2</td> </tr> <tr> <td>Enclosure class (IEC 34-5):</td> <td>55 Dust/Jetting</td> </tr> <tr> <td>Insulation class (IEC 85):</td> <td>F</td> </tr> <tr> <td>Motor No:</td> <td>85U17522</td> </tr> <tr> <td colspan="2">Others:</td> </tr> <tr> <td>Terminal box position:</td> <td>6</td> </tr> <tr> <td>Minimum efficiency index, MEI ≥:</td> <td>0.70</td> </tr> <tr> <td>Net weight:</td> <td>106 kg</td> </tr> <tr> <td>Gross weight:</td> <td>124 kg</td> </tr> <tr> <td>Shipping volume:</td> <td>0.23 m<sup>3</sup></td> </tr> <tr> <td>Danish VVS No.:</td> <td>386970002</td> </tr> <tr> <td>Country of origin:</td> <td>HU</td> </tr> <tr> <td>Custom tariff no.:</td> <td>84137075</td> </tr> </table>	Rated power - P2:	7.5 kW	Mains frequency:	50 Hz	Suitable for 50/60 Hz:	N	Rated voltage:	3 x 380-415D/660-690Y V	Rated current:	14,4-14,0/8,30-8,10 A	Starting current:	780-910 %	Cos phi - power factor:	0.88-0.82	Rated speed:	2910-2920 rpm	Efficiency:	IE3 90,1%	Motor efficiency at full load:	90.1-90.4 %	Motor efficiency at 3/4 load:	90.8 %	Motor efficiency at 1/2 load:	90.8 %	Number of poles:	2	Enclosure class (IEC 34-5):	55 Dust/Jetting	Insulation class (IEC 85):	F	Motor No:	85U17522	Others:		Terminal box position:	6	Minimum efficiency index, MEI ≥:	0.70	Net weight:	106 kg	Gross weight:	124 kg	Shipping volume:	0.23 m <sup>3</sup>	Danish VVS No.:	386970002	Country of origin:	HU	Custom tariff no.:	84137075
Rated power - P2:	7.5 kW																																																		
Mains frequency:	50 Hz																																																		
Suitable for 50/60 Hz:	N																																																		
Rated voltage:	3 x 380-415D/660-690Y V																																																		
Rated current:	14,4-14,0/8,30-8,10 A																																																		
Starting current:	780-910 %																																																		
Cos phi - power factor:	0.88-0.82																																																		
Rated speed:	2910-2920 rpm																																																		
Efficiency:	IE3 90,1%																																																		
Motor efficiency at full load:	90.1-90.4 %																																																		
Motor efficiency at 3/4 load:	90.8 %																																																		
Motor efficiency at 1/2 load:	90.8 %																																																		
Number of poles:	2																																																		
Enclosure class (IEC 34-5):	55 Dust/Jetting																																																		
Insulation class (IEC 85):	F																																																		
Motor No:	85U17522																																																		
Others:																																																			
Terminal box position:	6																																																		
Minimum efficiency index, MEI ≥:	0.70																																																		
Net weight:	106 kg																																																		
Gross weight:	124 kg																																																		
Shipping volume:	0.23 m <sup>3</sup>																																																		
Danish VVS No.:	386970002																																																		
Country of origin:	HU																																																		
Custom tariff no.:	84137075																																																		

# On request MTR 45-2/2 A-F-A-HUUV 50 Hz

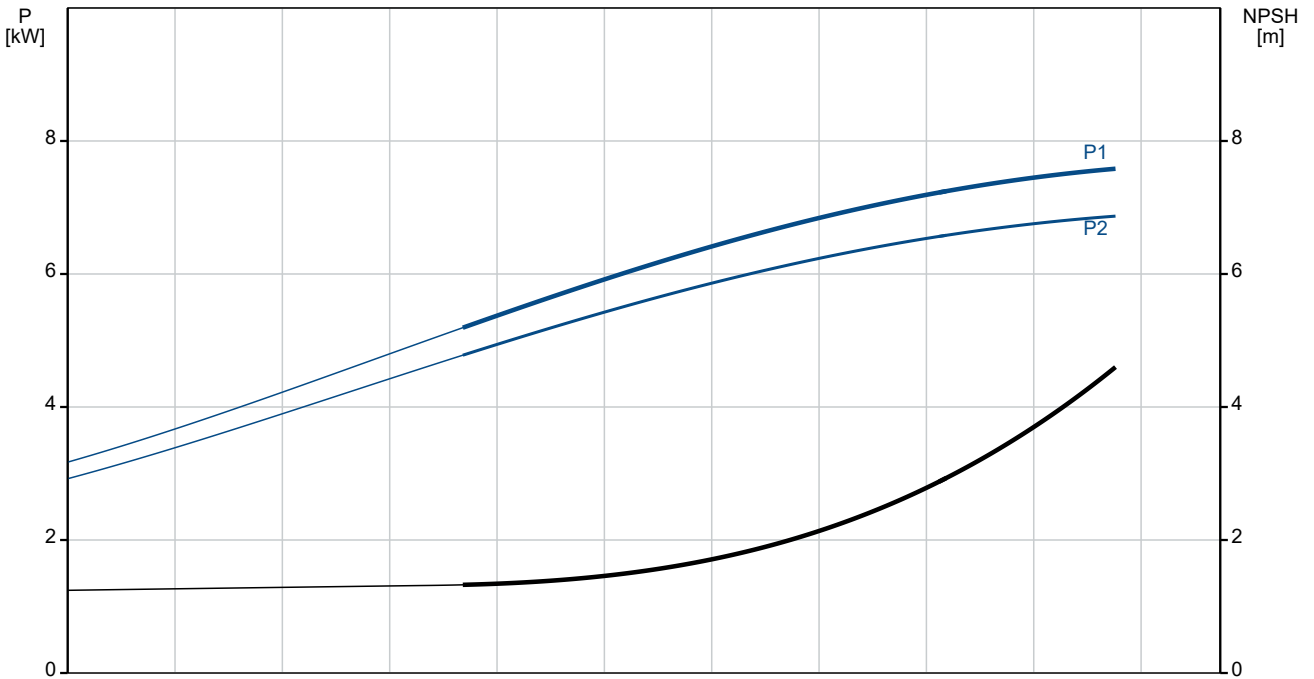
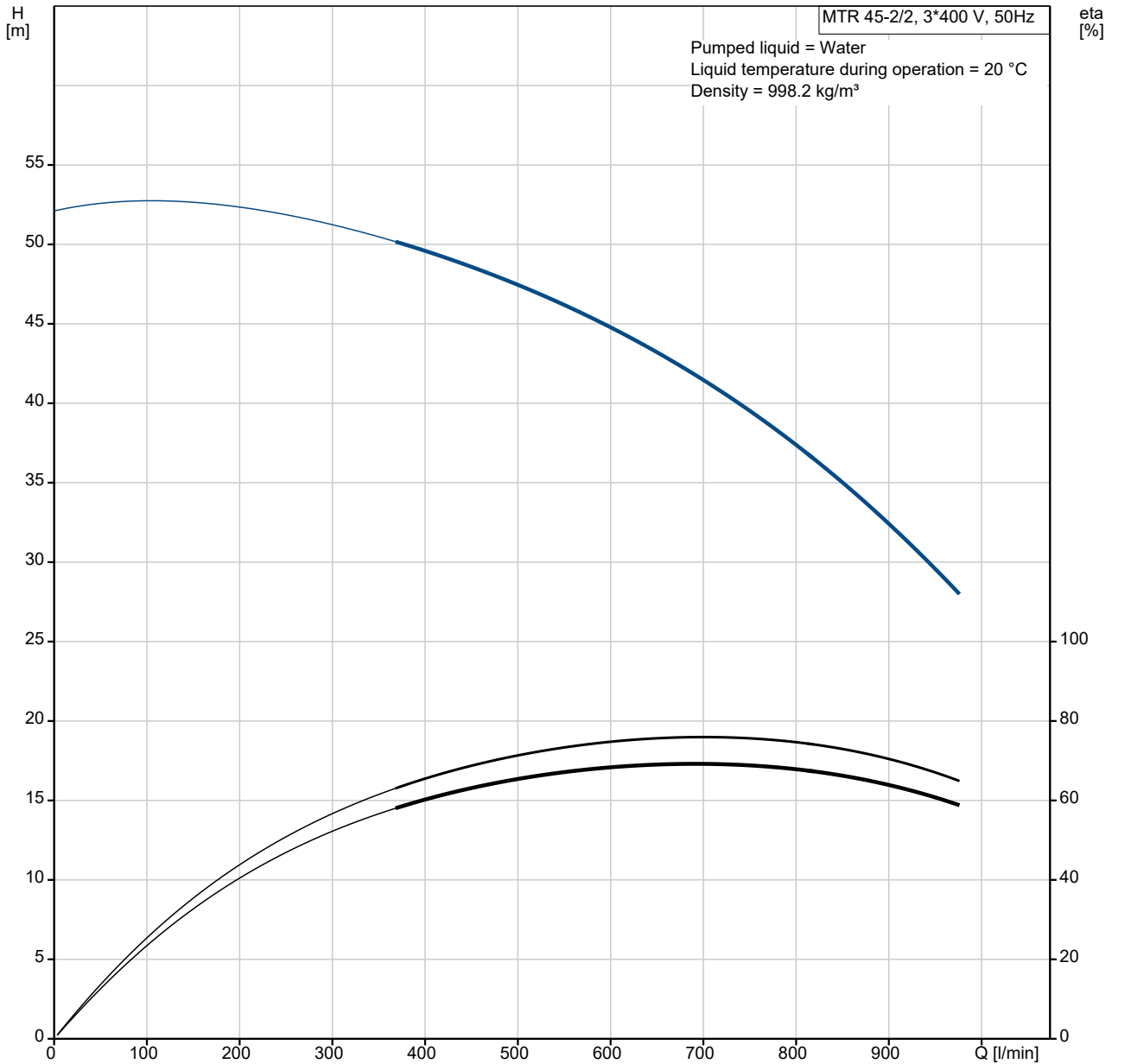

Description	Value
<b>General information:</b>	
Product name:	MTR 45-2/2 A-F-A-HUUV
Product No:	On request
EAN number:	On request
<b>Technical:</b>	
Pump speed on which pump data are based:	2919 rpm
Rated flow:	750 l/min
Rated head:	36.6 m
Chambers:	2
Impellers:	2
Number of reduced-diameter impellers:	0
Drainage back to tank:	N
Pump orientation:	Vertical
Code for shaft seal:	HUUV
Approvals:	CE, EAC
Curve tolerance:	ISO9906:2012 3B
Pump version:	A
Model:	B
<b>Materials:</b>	
Pump head:	Cast iron
Pump head:	EN 1561 EN-GJL-200
Pump head:	ASTM A48-25B
Impeller:	Stainless steel
Impeller:	EN 1.4301
Impeller:	AISI 304
Material code:	A
<b>Installation:</b>	
t max amb:	60 °C
Maximum operating pressure:	25 bar
Max pressure at stated temp:	25 bar / 90 °C
Type of connection:	DIN
Size of outlet connection:	DN 80
Immersion depth:	244 mm
Pressure rating for connection:	PN 40
Flange size for motor:	FF265
Connect code:	F
<b>Liquid:</b>	
Pumped liquid:	Water
Liquid temperature range:	-10 .. 90 °C
Selected liquid temperature:	20 °C
Density:	998.2 kg/m <sup>3</sup>
<b>Electrical data:</b>	
Motor standard:	IEC
Motor type:	132SB
IE Efficiency class:	IE3
Rated power - P2:	7.5 kW
Mains frequency:	50 Hz
Suitable for 50/60 Hz:	N
Rated voltage:	3 x 380-415D/660-690Y V
Rated current:	14,4-14,0/8,30-8,10 A
Starting current:	780-910 %
Cos phi - power factor:	0.88-0.82
Rated speed:	2910-2920 rpm
Efficiency:	IE3 90,1%
Motor efficiency at full load:	90.1-90.4 %
Motor efficiency at 3/4 load:	90.8 %
Motor efficiency at 1/2 load:	90.8 %
Number of poles:	2
Enclosure class (IEC 34-5):	55 Dust/Jetting
Insulation class (IEC 85):	F
Built-in motor protection:	PTC
Motor No:	85U17522

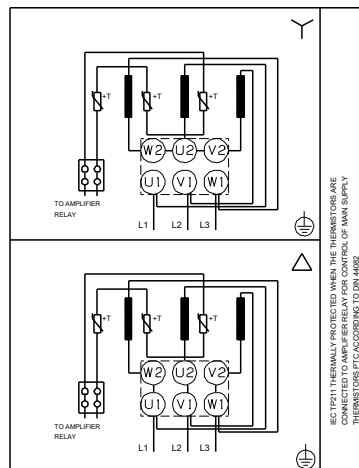
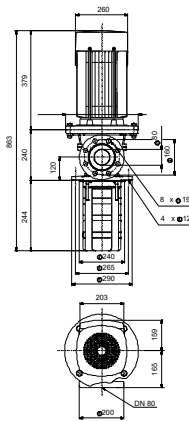
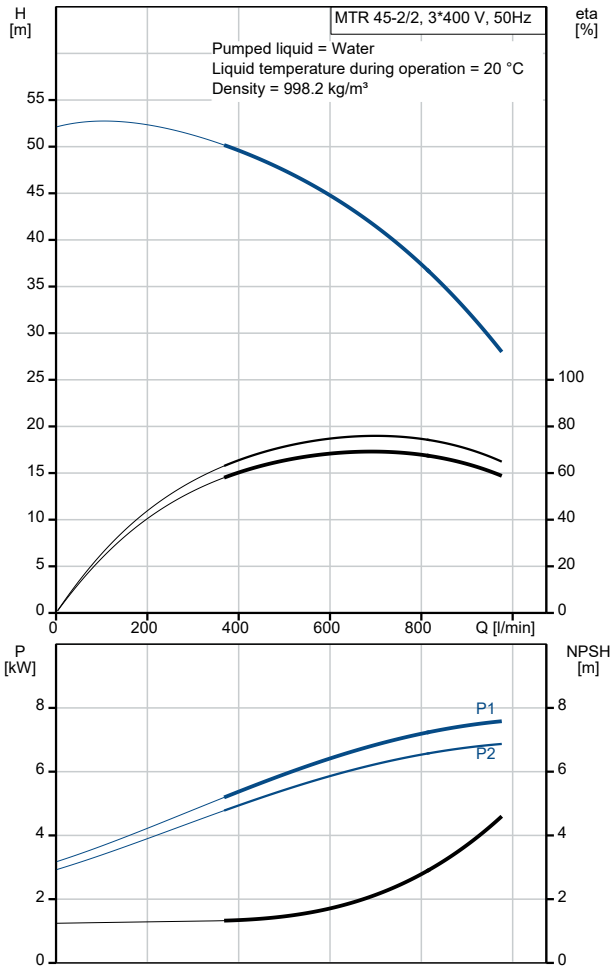

Description	Value
<b>Controls:</b>	
Frequency converter:	NONE
<b>Others:</b>	
Terminal box position:	6
Minimum efficiency index, MEI ≥:	0.70
Net weight:	106 kg
Gross weight:	124 kg
Shipping volume:	0.23 m <sup>3</sup>
Danish VVS No.:	386970002
Country of origin:	HU
Custom tariff no.:	84137075

# On request MTR 45-2/2 A-F-A-HUUV 50 Hz

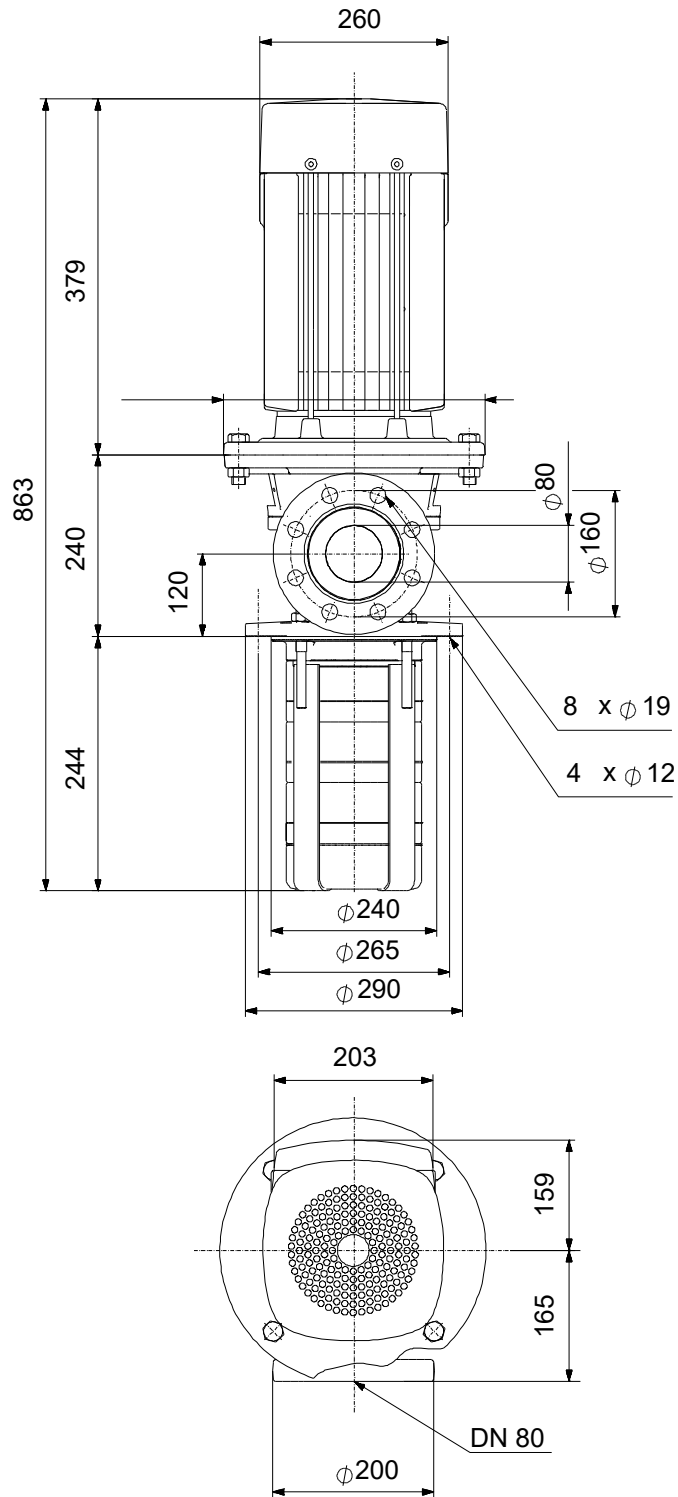

Note! All units are in [mm] unless others are stated.  
Disclaimer: This simplified dimensional drawing does not show all details.

**On request MTR 45-2/2 A-F-A-HUUV 50 Hz**



IEC TP211 THERMALLY PROTECTED WHEN THE THERMISTORS ARE  
CONNECTED TO AMPLIFIER RELAY FOR CONTROL OF MAIN SUPPLY  
THERMISTORS PTC ACCORDING TO DIN 44082

Note! All units are in [mm] unless others are stated.

