

Qty. Description

1 TP 65-170/2 A-F-A-BQQE-IX1



Note! Product picture may differ from actual product

Product No.: On request

Single-stage, close-coupled, volute pump with in-line suction and discharge ports of identical diameter.

The pump is of the top-pull-out design, i.e. the power head (motor, pump head and impeller) can be removed for maintenance or service while the pump housing remains in the pipework.

The pump is fitted with an unbalanced rubber bellows seal.

The shaft seal is according to EN 12756. Pipework connection is via PN 16 DIN flanges (EN 1092-2 and ISO 7005-2).

The pump is fitted with a fan-cooled asynchronous motor.

The product's minimum efficiency index (MEI) is greater or equal to 0.70. This is by the Commission Regulation (EU) considered as an indicative benchmark for best-performing water pump available on the market as from 1 January 2013.

Cast-iron parts have an epoxy-based coating made in a cathodic electro-deposition (CED) process. CED is a high-quality dip-painting process where an electrical field around the products ensures deposition of paint particles as a thin, well-controlled layer on the surface.

Pump

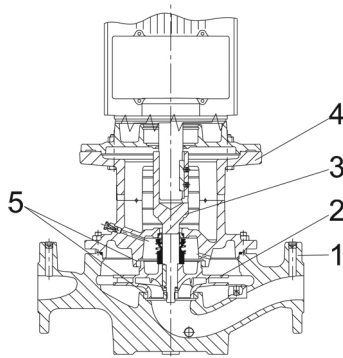

1: Pump housing

2: Impeller

3: Stub shaft

4: Pump head/motor stool

5: Wear rings

The pump housing is provided with a replaceable brass neck ring to reduce the amount of liquid running from the outlet side of the impeller to the inlet side.

The impeller is secured to the shaft with a nut.

The pump is fitted with an unbalanced rubber bellows seal with torque transmission across the spring and around the bellows. Due to the bellows, the seal does not wear the shaft, and the axial movement is not prevented by deposits on the shaft.

Seal faces:

- Rotating seal ring material: silicon carbide (SiC)
- Stationary seat material: silicon carbide (SiC)

This material pairing is used where higher corrosion resistance is required. The high hardness of this material pairing offers good resistance against abrasive particles.

Qty.	Description
	<p>Max pressure at stated temp: 16 bar / 120 °C</p> <p>Type of connection: DIN</p> <p>Size of connection: DN 65</p> <p>Pressure rating for connection: PN 16</p> <p>Port-to-port length: 360 mm</p> <p>Flange size for motor: FF165</p> <p>Electrical data:</p> <p>Motor type: 90LE</p> <p>IE Efficiency class: IE3</p> <p>Rated power - P2: 2.2 kW</p> <p>Mains frequency: 50 Hz</p> <p>Rated voltage: 3 x 380-415D V</p> <p>Rated current: 4.65 A</p> <p>Starting current: 840-920 %</p> <p>Rated speed: 2890-2910 rpm</p> <p>Efficiency: IE3 85,9%</p> <p>Motor efficiency at full load: 85.9 %</p> <p>Motor efficiency at 3/4 load: 88.2 %</p> <p>Motor efficiency at 1/2 load: 88.0 %</p> <p>Number of poles: 2</p> <p>Enclosure class (IEC 34-5): 55 Dust/Jetting</p> <p>Insulation class (IEC 85): F</p> <p>Motor No: 99605763</p> <p>Others:</p> <p>Minimum efficiency index, MEI ≥: 0.70</p> <p>Net weight: 56 kg</p> <p>Gross weight: 68 kg</p> <p>Shipping volume: 0.22 m³</p> <p>Finnish LVI No.: 4616075</p> <p>Country of origin: HU</p> <p>Custom tariff no.: 84137051</p>

Description	Value
General information:	
Product name:	TP 65-170/2 A-F-A-BQQE-IX1
Product No:	On request
EAN number:	On request
Technical:	
Pump speed on which pump data are based:	2900 rpm
Rated flow:	41.7 m ³ /h
Rated head:	13.3 m
Maximum head:	170 dm
Actual impeller diameter:	116 mm
Code for shaft seal:	BQQE
Curve tolerance:	ISO9906:2012 3B2
Pump version:	A
Materials:	
Pump housing:	Cast iron
Pump housing:	EN-GJL-250
Pump housing:	ASTM class 35
Impeller:	Cast iron
Impeller:	EN-GJL-200
Impeller:	ASTM class 30
Material code:	A
Installation:	
Range of ambient temperature:	-30 .. 60 °C
Maximum operating pressure:	16 bar
Max pressure at stated temp:	16 bar / 120 °C
Type of connection:	DIN
Size of connection:	DN 65
Pressure rating for connection:	PN 16
Port-to-port length:	360 mm
Flange size for motor:	FF165
Connect code:	F
Liquid:	
Pumped liquid:	Water
Liquid temperature range:	-25 .. 120 °C
Selected liquid temperature:	20 °C
Density:	998.2 kg/m ³
Electrical data:	
Motor type:	90LE
IE Efficiency class:	IE3
Rated power - P2:	2.2 kW
Mains frequency:	50 Hz
Rated voltage:	3 x 380-415D V
Rated current:	4.65 A
Starting current:	840-920 %
Rated speed:	2890-2910 rpm
Efficiency:	IE3 85,9%
Motor efficiency at full load:	85.9 %
Motor efficiency at 3/4 load:	88.2 %
Motor efficiency at 1/2 load:	88.0 %
Number of poles:	2
Enclosure class (IEC 34-5):	55 Dust/Jetting
Insulation class (IEC 85):	F
Built-in motor protection:	NONE
Motor No:	99605763
Controls:	
Frequency converter:	NONE
Others:	

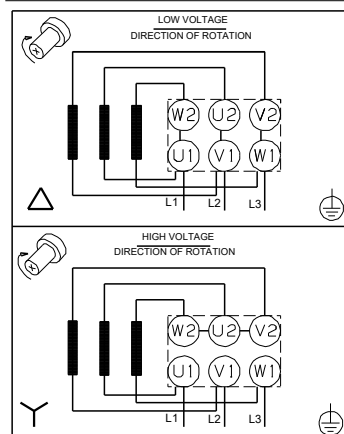
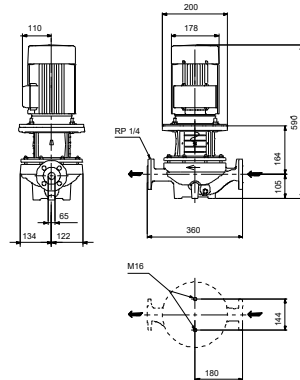
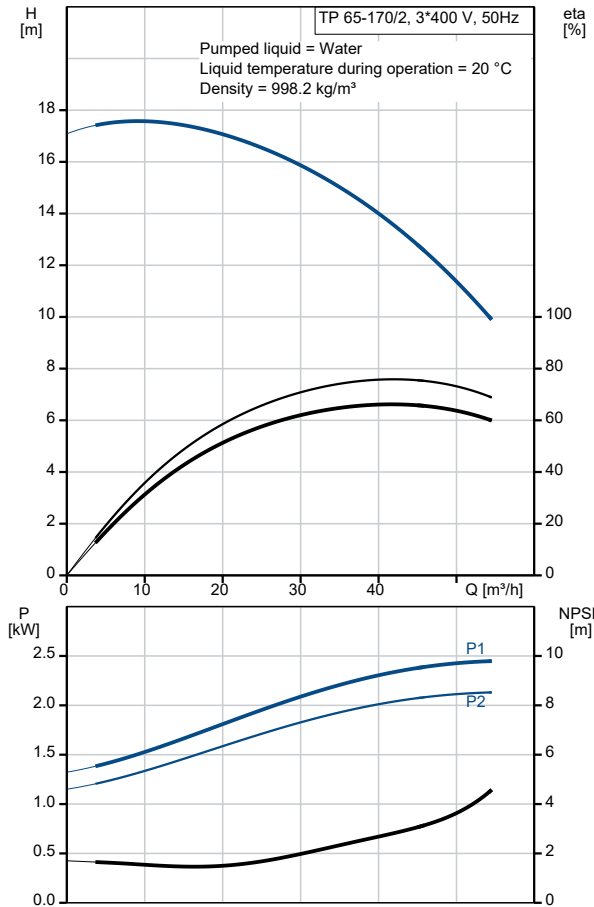



Company name:

Created by:

Phone:

Date:

16/06/2022

Description	Value
Minimum efficiency index, MEI ≥:	0.70
Net weight:	56 kg
Gross weight:	68 kg
Shipping volume:	0.22 m ³
Finnish LVI No.:	4616075
Country of origin:	HU
Custom tariff no.:	84137051

On request TP 65-170/2 A-F-A-BQQE-IX1 50 Hz

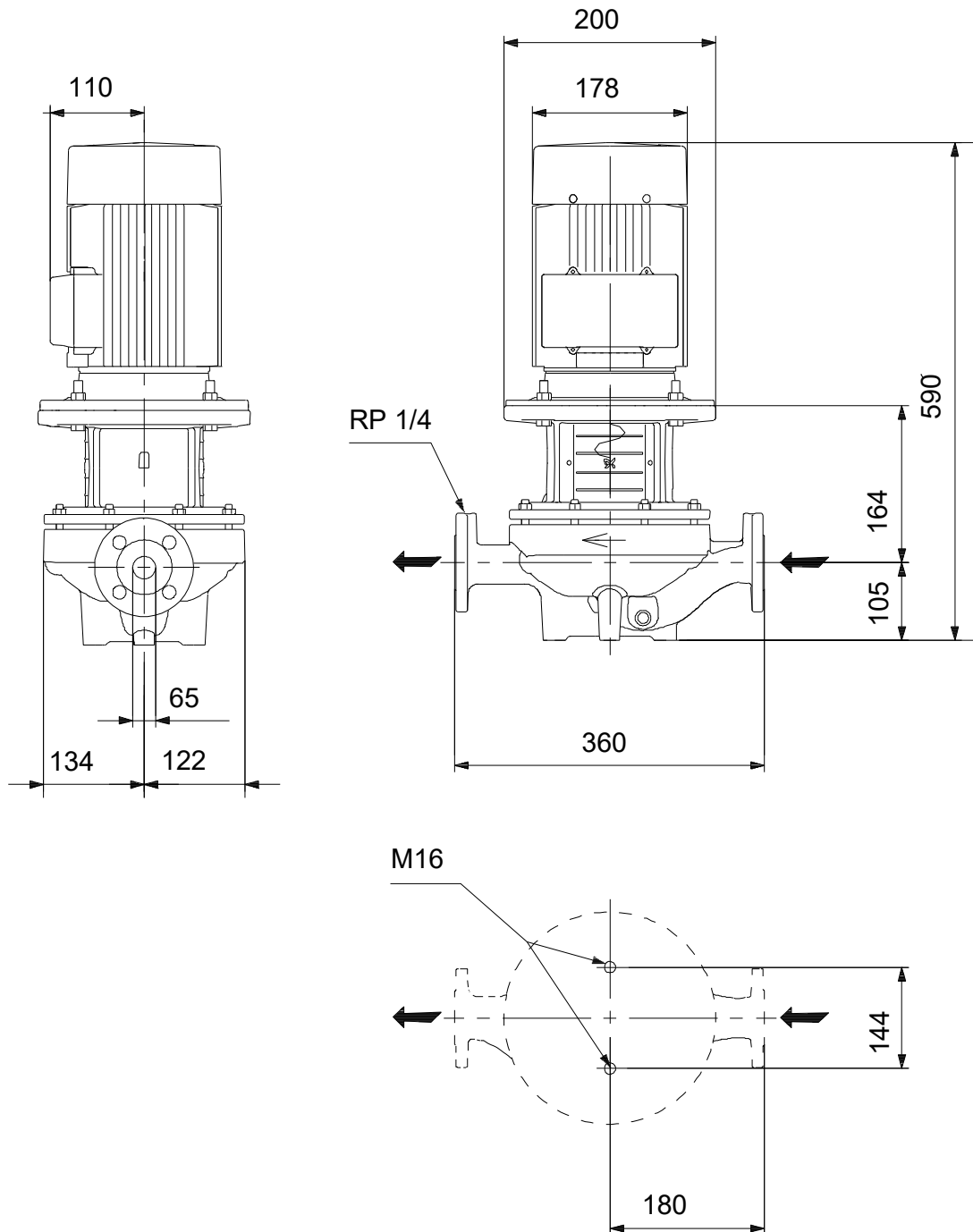

Note! All units are in [mm] unless others are stated.
Disclaimer: This simplified dimensional drawing does not show all details.

On request TP 65-170/2 A-F-A-BQQE-IX1 50 Hz

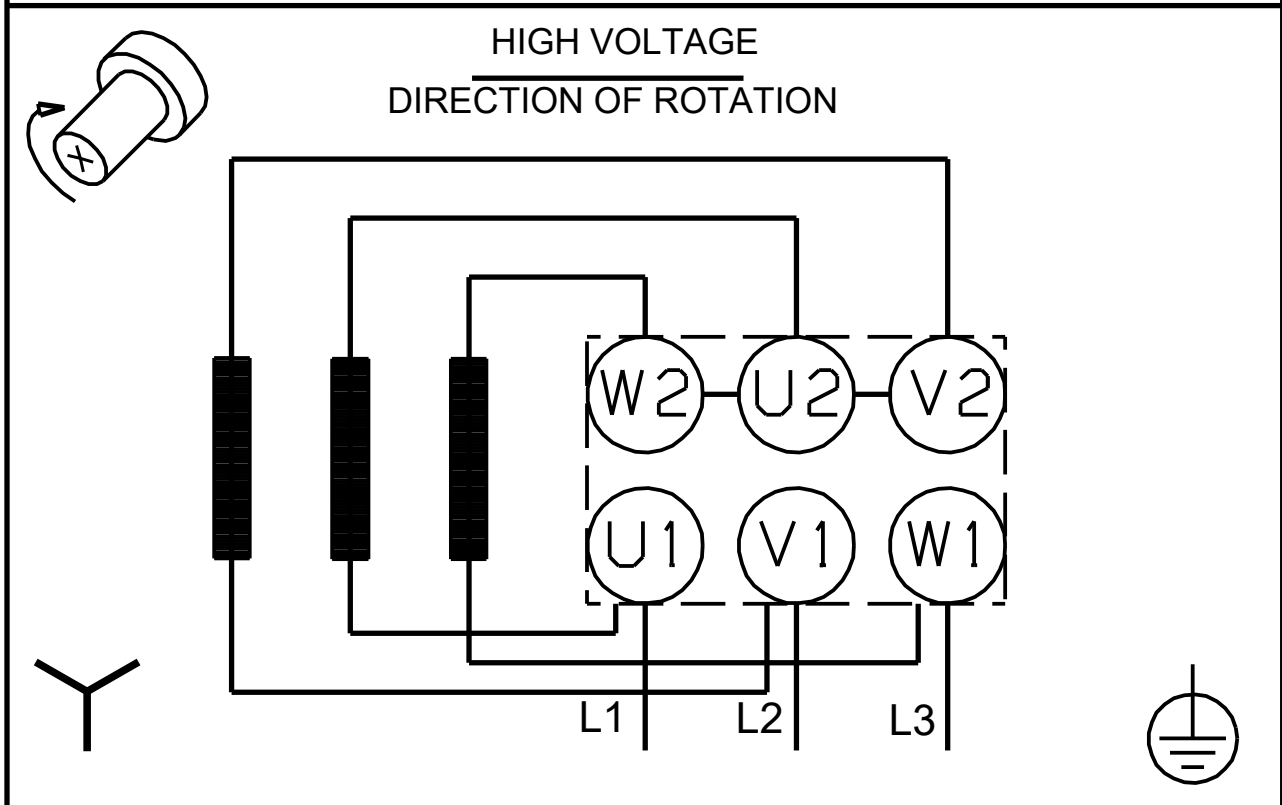
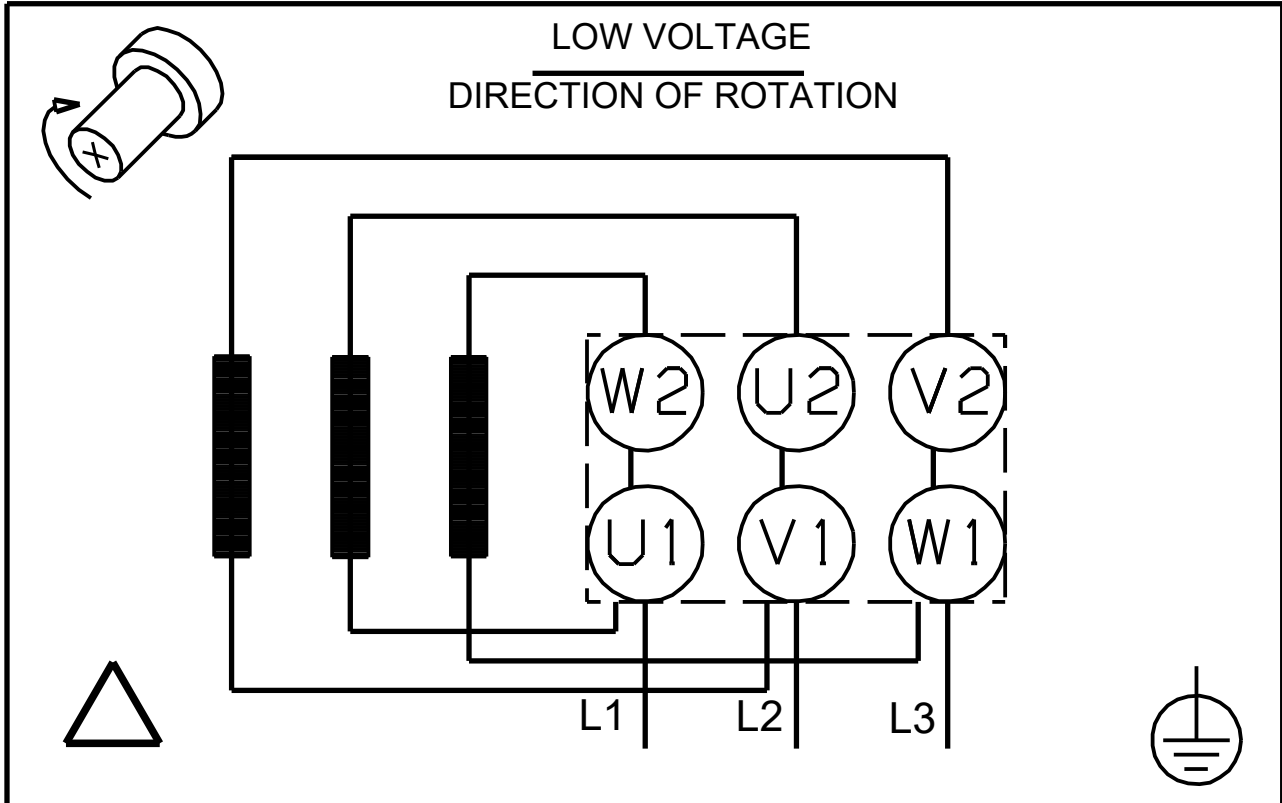

Note! All units are in [mm] unless others are stated.



Company name:

Created by:

Phone:

Date:

16/06/2022

Order Data:

Product name: TP 65-170/2

Amount: 1

Product No: On request

Total: Price on request
