

Qty. Description

1 TPD 125-80/6 A-F-A-BQQE-JX5



Note! Product picture may differ from actual product

Product No.: [98743808](#)

Single-stage, close-coupled, volute twin-head pump with in-line suction and discharge ports of identical diameter. The twin-head pump is designed with two parallel power-heads.

The pump is of the top-pull-out design, i.e. the power head (motor, pump head and impeller) can be removed for maintenance or service while the pump housing remains in the pipework.

Each power head is fitted with an unbalanced rubber bellows seal.

The shaft seal is according to EN 12756. Pipework connection is via PN 16 DIN flanges (EN 1092-2 and ISO 7005-2).

Each power head is fitted with a fan-cooled asynchronous motor of identical size.

The product's minimum efficiency index (MEI) is greater or equal to 0.70. This is by the Commission Regulation (EU) considered as an indicative benchmark for best-performing water pump available on the market as from 1 January 2013.

Cast-iron parts have an epoxy-based coating made in a cathodic electro-deposition (CED) process. CED is a high-quality dip-painting process where an electrical field around the products ensures deposition of paint particles as a thin, well-controlled layer on the surface.

Pump

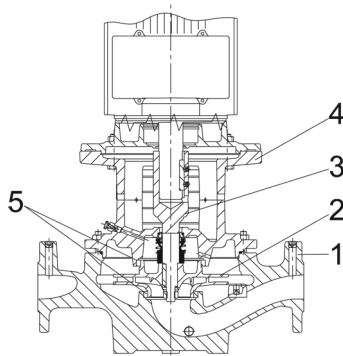

1: Pump housing

2: Impeller

3: Stub shaft

4: Pump head/motor stool

5: Wear rings

The twin-head pump is designed with two parallel power-heads. A non-return flap valve in the common discharge port is opened by the flow of the pumped liquid and prevents backflow of liquid into the idle pump head.

The pump housing is provided with a replaceable brass neck ring to reduce the amount of liquid running from the outlet side of the impeller to the inlet side.

The impeller is secured to the shaft with a nut.

The pump is fitted with an unbalanced rubber bellows seal with torque transmission across the spring and around the bellows. Due to the bellows, the seal does not wear the shaft, and the axial movement is not prevented by deposits on the shaft.

Seal faces:

- Rotating seal ring material: silicon carbide (SiC)

Qty. Description

1

- Stationary seat material: silicon carbide (SiC)

This material pairing is used where higher corrosion resistance is required. The high hardness of this material pairing offers good resistance against abrasive particles.

Secondary seal material: EPDM (ethylene-propylene rubber)

EPDM has excellent resistance to hot water. EPDM is not suitable for mineral oils.

A circulation of liquid through the duct of the air vent screw ensures lubrication and cooling of the shaft seal.

The pump housing has four Rp 1/8 tapings for mounting of automatic air vents. Fit an air vent to the upper pump housing if the twin-head pump is to be installed in a horizontal pipeline with horizontal pump shaft.

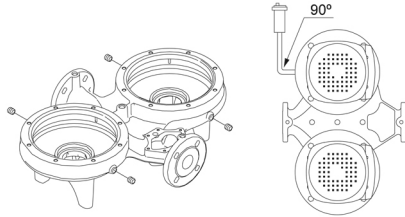

The flanges have tappings for mounting of pressure gauges.

The motor stool forms connection between the pump housing and the motor, and is equipped with a manual air vent screw for venting of the pump housing and the shaft seal chamber. The sealing between motor stool and pump housing is an O-ring.

The central part of the motor stool is provided with guards for protection against the shaft and coupling. The pump shaft is fastened directly on the motor shaft with key and set screws.

Motor

The motor is a totally enclosed, fan-cooled motor with principal dimensions to IEC and DIN standards. Electrical tolerances comply with IEC 60034.

The motor is flange-mounted with free-hole flange (FF).

Motor-mounting designation in accordance with IEC 60034-7: IM B 5, IM V 1 (Code I) / IM 3001, IM 3011 (Code II).

The motor efficiency is classified as IE3 in accordance with IEC 60034-30-1.

The motor has thermistors (PTC sensors) in the windings in accordance with DIN 44081/DIN 44082. The protection reacts to both slow- and quick-rising temperatures, e.g. constant overload and stalled conditions.

Thermal switches must be connected to an external control circuit in a way which ensures that the automatic reset cannot cause accidents. The motors must be connected to a motor-protective circuit breaker according to local regulations.

The motor can be connected to a variable speed drive for adjustment of pump performance to any duty point. Grundfos CUE offers a range of variable speed drives. Please find more information in Grundfos Product Center.

Further product details

Cast-iron parts have an epoxy-based coating made in a cathodic electro-deposition (CED) process. CED is a high-quality dip-painting process where an electrical field around the products ensures deposition of paint particles as a thin, well-controlled layer on the surface.

Technical data

Controls:

Frequency converter: NONE

Liquid:

Pumped liquid: Water

Liquid temperature range: -25 .. 120 °C

Selected liquid temperature: 20 °C

Density: 998.2 kg/m³

Technical:

Pump speed on which pump data are based: 975 rpm

Rated flow: 92.5 m³/h

Rated head: 7.08 m

Qty.	Description
1	<p>Actual impeller diameter: 236 mm Code for shaft seal: BQQE Curve tolerance: ISO9906:2012 3B2</p> <p>Materials:</p> <p>Pump housing: Cast iron EN-GJL-250 ASTM class 35</p> <p>Impeller: Cast iron EN-GJL-200 ASTM class 30</p> <p>Installation:</p> <p>Range of ambient temperature: -20 .. 55 °C Maximum operating pressure: 16 bar Max pressure at stated temp: 16 bar / 120 °C Type of connection: DIN Size of connection: DN 125 Pressure rating for connection: PN 16 Port-to-port length: 800 mm Flange size for motor: FF265</p> <p>Electrical data:</p> <p>Motor type: SIEMENS IE Efficiency class: IE3 Rated power - P2: 3 kW Mains frequency: 50 Hz Rated voltage: 3 x 220-240D/380-420Y V Rated current: 12.1/6.9 A Starting current: 660-660 % Cos phi - power factor: 0.73 Rated speed: 975 rpm Efficiency: IE3 85,6% Motor efficiency at full load: 85.6-85.6 % Motor efficiency at 3/4 load: 85.8-85.8 % Motor efficiency at 1/2 load: 84.3-84.3 % Number of poles: 6 Enclosure class (IEC 34-5): IP55 Insulation class (IEC 85): F Motor No: 83W05210</p> <p>Others:</p> <p>Minimum efficiency index, MEI ≥: 0.70 Net weight: 460 kg Gross weight: 569 kg Shipping volume: 1.53 m³ Country of origin: HU Custom tariff no.: 84137065</p>

98743808 TPD 125-80/6 A-F-A-BQQE-JX5 50 Hz

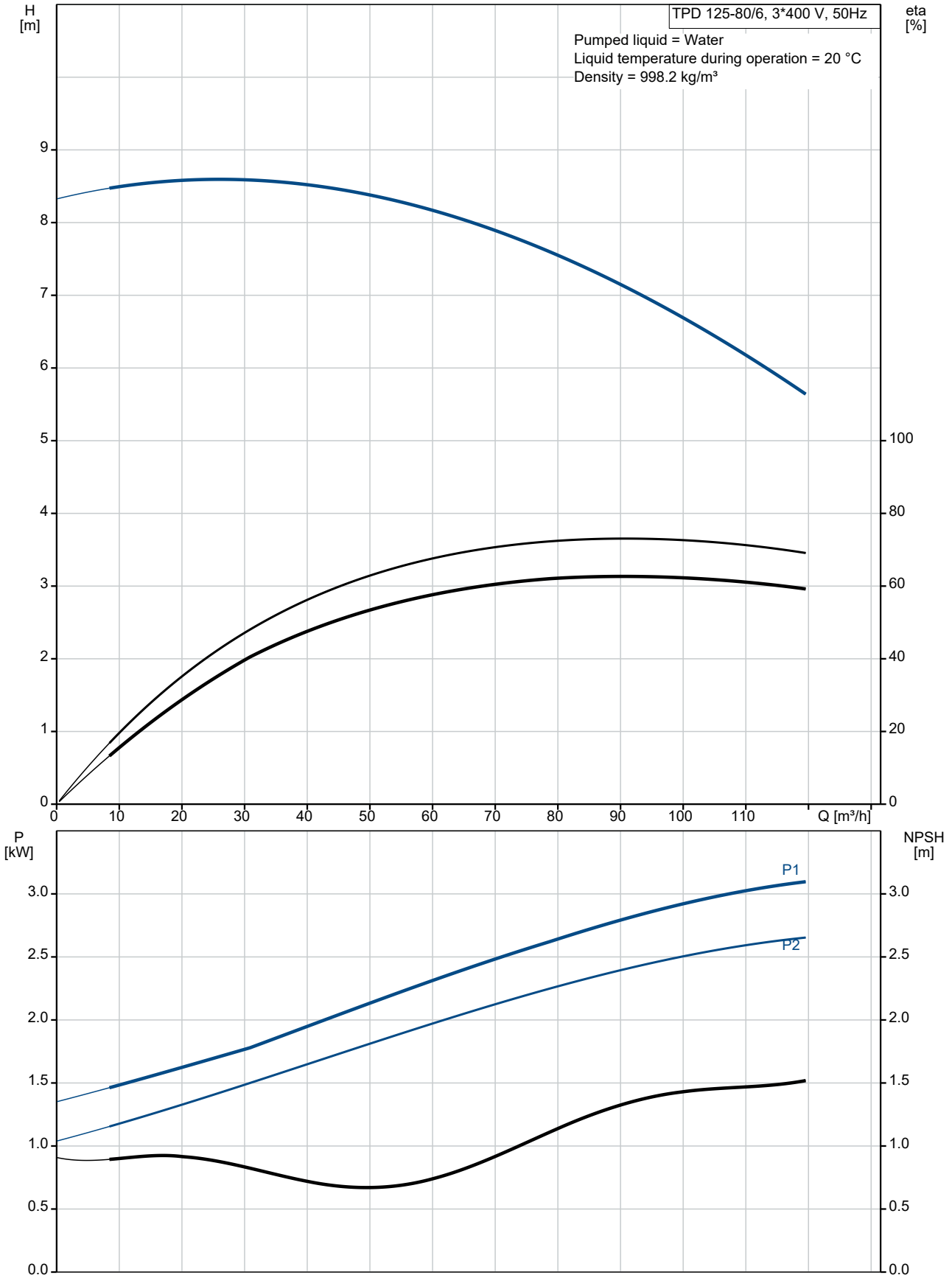

Description	Value
General information:	
Product name:	TPD 125-80/6 A-F-A-BQQE-JX5
Product No:	98743808
EAN number:	5712600825291
Technical:	
Pump speed on which pump data are based:	975 rpm
Rated flow:	92.5 m ³ /h
Rated head:	7.08 m
Maximum head:	80 dm
Actual impeller diameter:	236 mm
Code for shaft seal:	BQQE
Curve tolerance:	ISO9906:2012 3B2
Pump version:	A
Materials:	
Pump housing:	Cast iron
Pump housing:	EN-GJL-250
Pump housing:	ASTM class 35
Impeller:	Cast iron
Impeller:	EN-GJL-200
Impeller:	ASTM class 30
Material code:	A
Installation:	
Range of ambient temperature:	-20 .. 55 °C
Maximum operating pressure:	16 bar
Max pressure at stated temp:	16 bar / 120 °C
Type of connection:	DIN
Size of connection:	DN 125
Pressure rating for connection:	PN 16
Port-to-port length:	800 mm
Flange size for motor:	FF265
Connect code:	F
Liquid:	
Pumped liquid:	Water
Liquid temperature range:	-25 .. 120 °C
Selected liquid temperature:	20 °C
Density:	998.2 kg/m ³
Electrical data:	
Motor type:	SIEMENS
IE Efficiency class:	IE3
Rated power - P2:	3 kW
Mains frequency:	50 Hz
Rated voltage:	3 x 220-240D/380-420Y V
Rated current:	12.1/6.9 A
Starting current:	660-660 %
Cos phi - power factor:	0.73
Rated speed:	975 rpm
Efficiency:	IE3 85,6%
Motor efficiency at full load:	85.6-85.6 %
Motor efficiency at 3/4 load:	85.8-85.8 %
Motor efficiency at 1/2 load:	84.3-84.3 %
Number of poles:	6
Enclosure class (IEC 34-5):	IP55
Insulation class (IEC 85):	F
Built-in motor protection:	PTC
Motor No:	83W05210
Controls:	
Frequency converter:	NONE

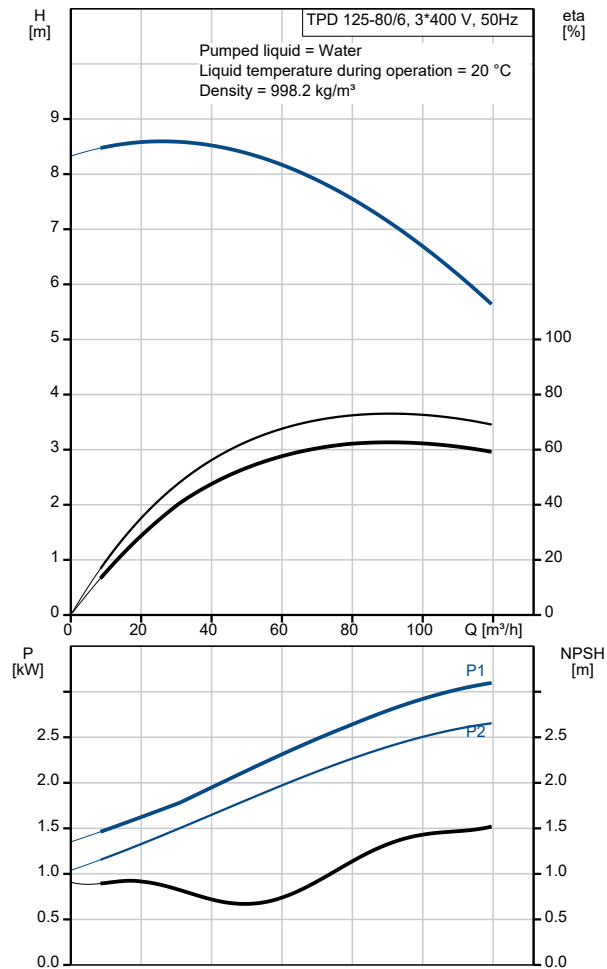



Company name:

Created by:

Phone:

Date:

08/08/2022

Description	Value
Others:	
Minimum efficiency index, MEI ≥:	0.70
Net weight:	460 kg
Gross weight:	569 kg
Shipping volume:	1.53 m ³
Country of origin:	HU
Custom tariff no.:	84137065

98743808 TPD 125-80/6 A-F-A-BQQE-JX5 50 Hz

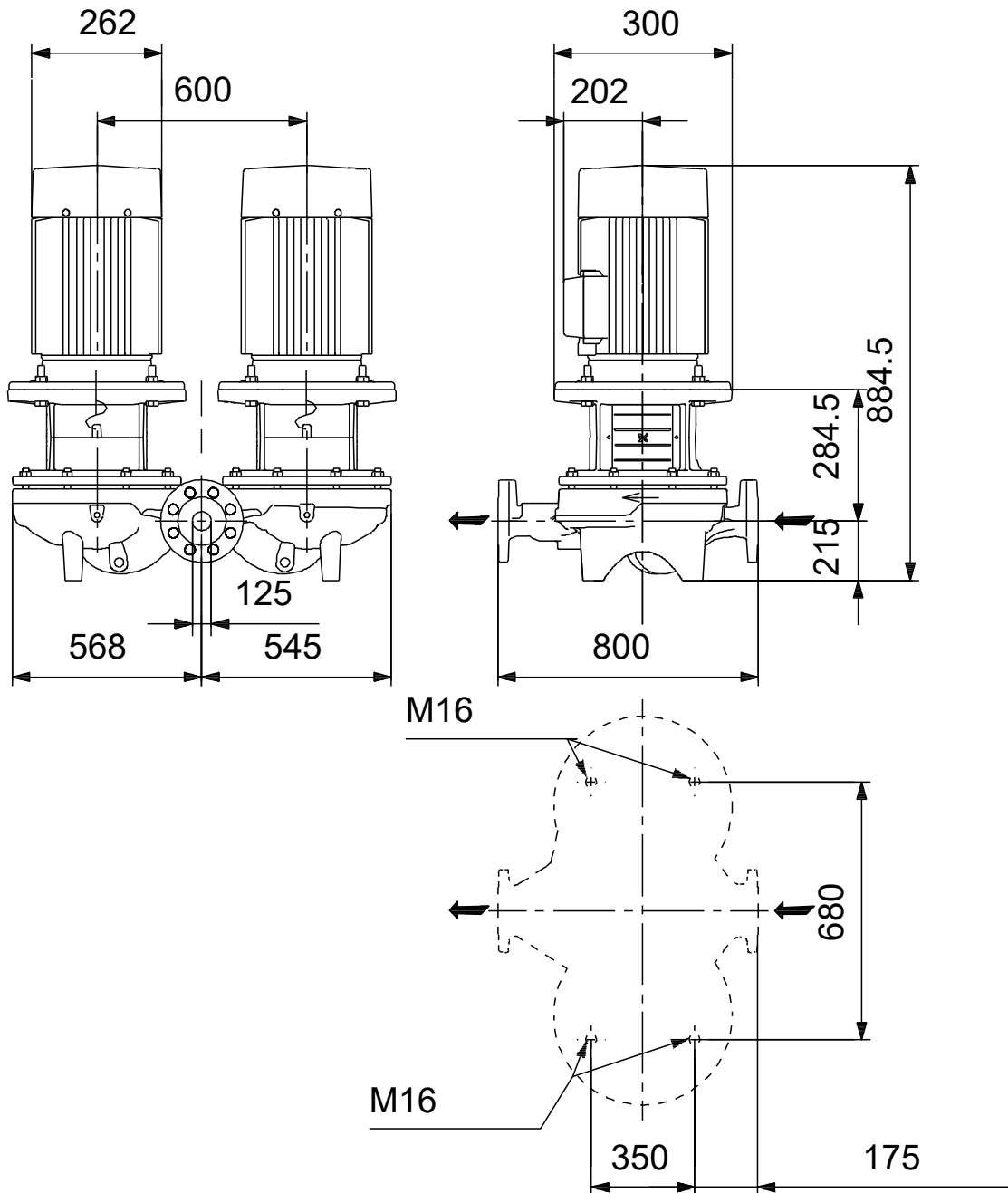

Note! All units are in [mm] unless others are stated.
Disclaimer: This simplified dimensional drawing does not show all details.

98743808 TPD 125-80/6 A-F-A-BQQE-JX5 50 Hz



Note! All units are in [mm] unless others are stated.