

Qty. Description

1 CRN 185-1-1 A-F-A-E-HQQE



Note! Product picture may differ from actual product

Product No.: [99143735](#)

Vertical, multistage centrifugal pump with inlet and outlet ports on same the level (inline). Pump materials in contact with the liquid are in high-grade stainless steel. The Grundfos cartridge shaft seal ensures high reliability, safe handling, and easy access and service. Power transmission is via a rigid split coupling. Pipe connection is via DIN flanges.

The pump is fitted with a 3-phase, fan-cooled asynchronous motor.

Further product details

Steel, cast iron and aluminium components have an epoxy-based coating made in a cathodic electro-deposition (CED) process.

CED is a high-quality dip-painting process where an electrical field around the products ensures deposition of paint particles as a thin, well-controlled layer on the surface.

An integral part of the process is a pretreatment.

The entire process consists of these elements:

- 1) Alkaline-based cleaning.
- 2) Zinc phosphating.
- 3) Cathodic electro-deposition.
- 4) Curing to a dry film thickness 18-22 my m.

The colour code for the finished product is NCS 9000/RAL 9005.

Pump

A long split coupling connects the pump and motor shaft. It is enclosed in the motor stool by means of two coupling guards. The long coupling makes it possible to replace the shaft seal without removing the motor from the pump.

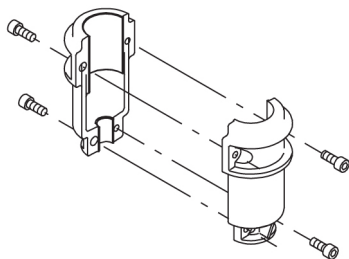

The motor stool connects the pump head and motor. The pump head has a combined 1/2" priming plug and vent screw.

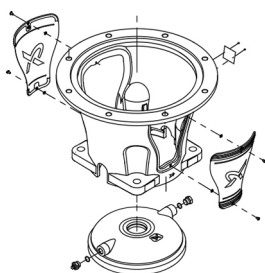

Qty. Description

1 The pump is fitted with a balanced O-ring seal unit with a rigid torque-transmission system. This seal type is assembled in a cartridge unit which makes replacement safe and easy. Due to the balancing, this seal type is suitable for high-pressure applications. The cartridge construction also protects the pump shaft from possible wear from a dynamic O-ring between pump shaft and shaft seal.

Seal faces:

- Rotating seal ring material: silicon carbide (SiC)
- Stationary seat material: silicon carbide (SiC)

This material pairing is used where higher corrosion resistance is required. The high hardness of this material pairing offers good resistance against abrasive particles.

Secondary seal material: EPDM (ethylene-propylene rubber)
EPDM has excellent resistance to hot water. EPDM is not suitable for mineral oils.

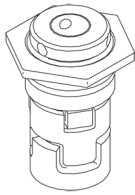

The shaft seal is screwed into the pump head.

The chambers and impellers are made of stainless-steel sheet. The chambers are provided with a PEEK neck ring offering improved sealing and high efficiency. The impellers have smooth surfaces, and the shape of the blades ensure a high efficiency.

The pump has a stainless-steel base mounted on a separate cast-iron base plate.

The base and base plate are kept in position by the tension of the staybolts which hold the pump together.

Both the inlet and the outlet side of the base have two pressure gauge tapings.

The pump is secured to the foundation by four bolts through the base plate.

The flanges are fastened to the base by means of locking rings.

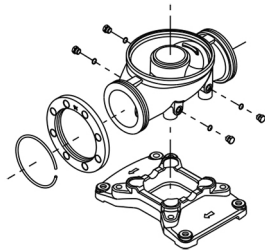

Motor

The motor is a totally enclosed, fan-cooled motor with principal dimensions to IEC and DIN standards. The motor is flange-mounted with free-hole flange (FF).

Motor-mounting designation in accordance with IEC 60034-7: IM B 5 (Code I) / IM 3001 (Code II).

Electrical tolerances comply with IEC 60034.

The motor efficiency is classified as IE3 in accordance with IEC 60034-30-1.

The motor has thermistors (PTC sensors) in the windings in accordance with DIN 44081/DIN 44082. The protection reacts to both slow- and quick-rising temperatures, e.g. constant overload and stalled conditions.

Thermal switches must be connected to an external control circuit in a way which ensures that the automatic reset cannot cause accidents. The motors must be connected to a motor-protective circuit breaker according to local regulations.

The motor can be connected to a variable speed drive for adjustment of pump performance to any duty point. Grundfos CUE offers a range of variable speed drives. Please find more information in Grundfos Product Center.

Technical data

Liquid:

Pumped liquid: Water

Liquid temperature range: -20 .. 120 °C

Selected liquid temperature: 20 °C

Qty.	Description
1	<p>Density: 998.2 kg/m³</p> <p>Technical:</p> <p>Pump speed on which pump data are based: 2951 rpm</p> <p>Rated flow: 185 m³/h</p> <p>Rated head: 28.1 m</p> <p>Pump orientation: Vertical</p> <p>Shaft seal arrangement: Single</p> <p>Code for shaft seal: HQQE</p> <p>Approvals: CE,EAC,UKCA,SEPRO</p> <p>Approvals for drinking water: ACS</p> <p>Curve tolerance: ISO9906:2012 3B</p> <p>Materials:</p> <p>Base: Stainless steel EN 1.4408 ASTM A351 CF8M</p> <p>Impeller: Stainless steel EN 1.4401 AISI 316</p> <p>Bearing: WC/WC</p> <p>Support bearing: Graflon</p> <p>Material certified according to: European standards</p> <p>Installation:</p> <p>t max amb: 60 °C</p> <p>Maximum operating pressure: 16 bar</p> <p>Max pressure at stated temp: 16 bar / 120 °C</p> <p>Type of connection: DIN</p> <p>Size of inlet connection: DN 200</p> <p>Size of outlet connection: DN 200</p> <p>Pressure rating for connection: PN 16</p> <p>Flange size for motor: FF300</p> <p>Electrical data:</p> <p>Motor standard: IEC</p> <p>Motor type: 160LB</p> <p>IE Efficiency class: IE3</p> <p>Rated power - P2: 18.5 kW</p> <p>Power (P2) required by pump: 18.5 kW</p> <p>Mains frequency: 50 Hz</p> <p>Rated voltage: 3 x 380-415D/660-690Y V</p> <p>Rated current: 34,5-32,5/20,0-18,8 A</p> <p>Starting current: 830-980 %</p> <p>Cos phi - power factor: 0.89-0.85</p> <p>Rated speed: 2940-2950 rpm</p> <p>Efficiency: IE3 92,4%</p> <p>Motor efficiency at full load: 92.4-92.4 %</p> <p>Motor efficiency at 3/4 load: 93.2 %</p> <p>Motor efficiency at 1/2 load: 93.2 %</p> <p>Number of poles: 2</p> <p>Enclosure class (IEC 34-5): 55 Dust/Jetting</p> <p>Insulation class (IEC 85): F</p> <p>Motor No: 85U17528</p> <p>Controls:</p> <p>Frequency converter: NONE</p> <p>Others:</p>



Company name:

Created by:

Phone:

Date:

02/01/2023

Qty.	Description
------	-------------

1	Minimum efficiency index, MEI \geq : 0.70 Net weight: 345 kg Gross weight: 466 kg Shipping volume: 1.25 m ³ Thrust handling device: N Country of origin: DK Custom tariff no.: 84137075
---	--

99143735 CRN 185-1-1 A-F-A-E-HQQE 50 Hz

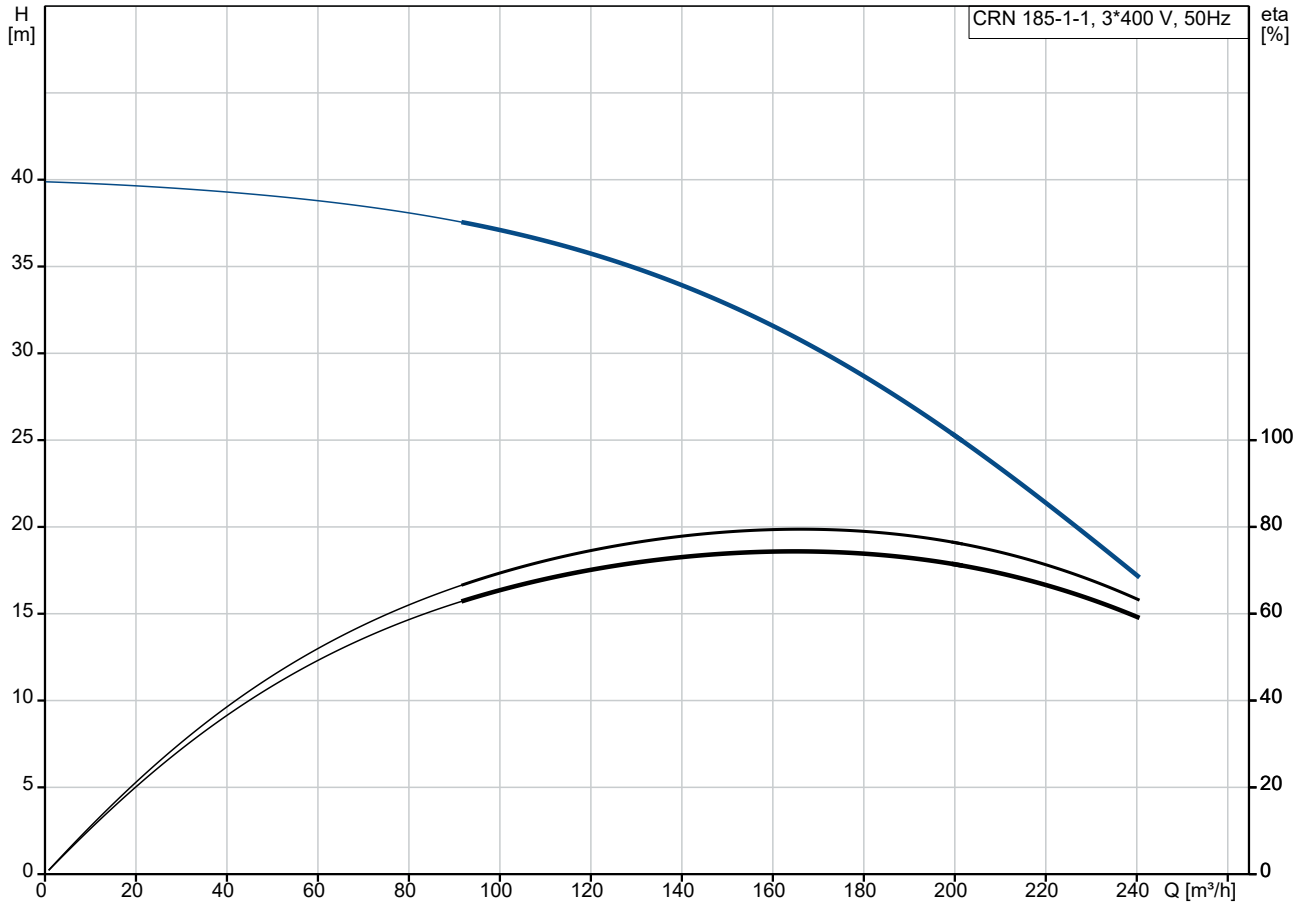

Pumped liquid = Water
Liquid temperature during operation = 20 °C
Density = 998.2 kg/m³

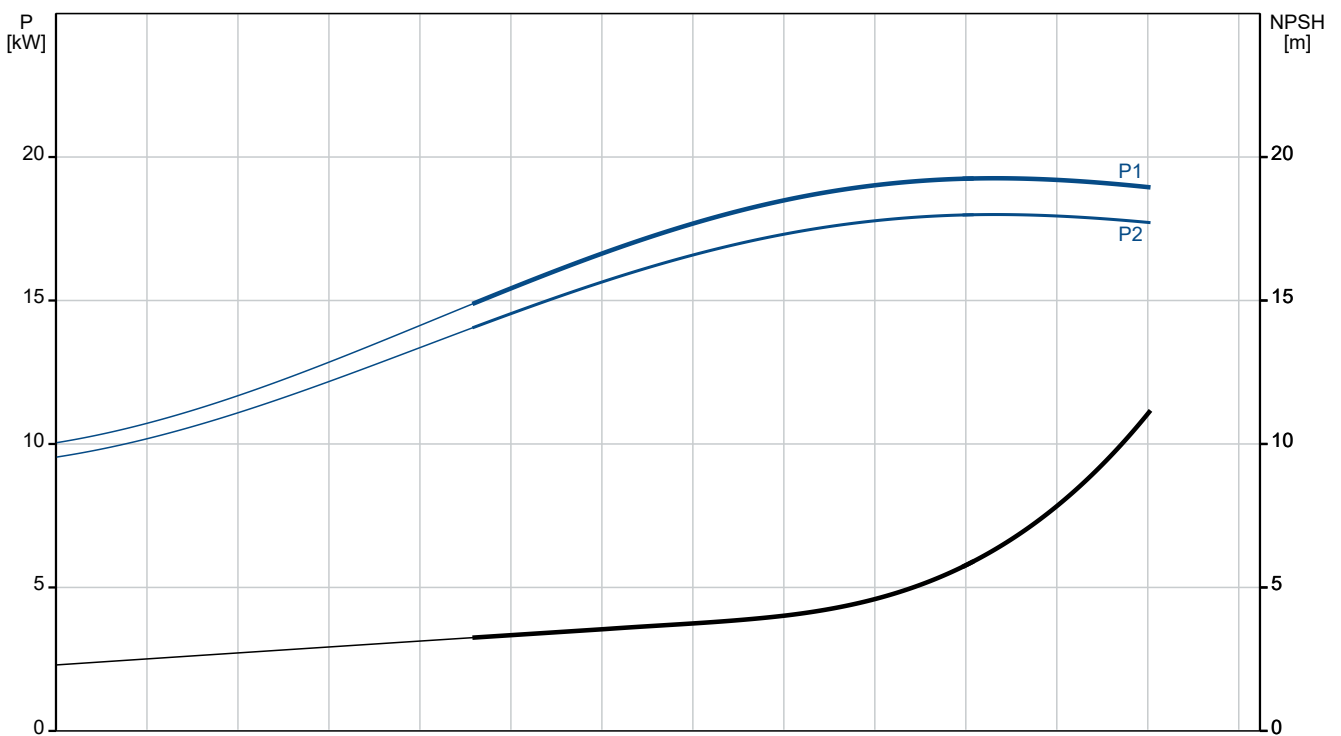



Company name:

Created by:

Phone:

Date:

02/01/2023

Description	Value
Rated voltage:	3 x 380-415D/660-690Y V
Rated current:	34,5-32,5/20,0-18,8 A
Starting current:	830-980 %
Cos phi - power factor:	0.89-0.85
Rated speed:	2940-2950 rpm
Efficiency:	IE3 92,4%
Motor efficiency at full load:	92.4-92.4 %
Motor efficiency at 3/4 load:	93.2 %
Motor efficiency at 1/2 load:	93.2 %
Number of poles:	2
Enclosure class (IEC 34-5):	55 Dust/Jetting
Insulation class (IEC 85):	F
Built-in motor protection:	PTC
Motor No:	85U17528
Controls:	
Frequency converter:	NONE
Others:	
Minimum efficiency index, MEI ≥:	0.70
Net weight:	345 kg
Gross weight:	466 kg
Shipping volume:	1.25 m ³
Thrust handling device:	N
Country of origin:	DK
Custom tariff no.:	84137075

99143735 CRN 185-1-1 A-F-A-E-HQQE 50 Hz

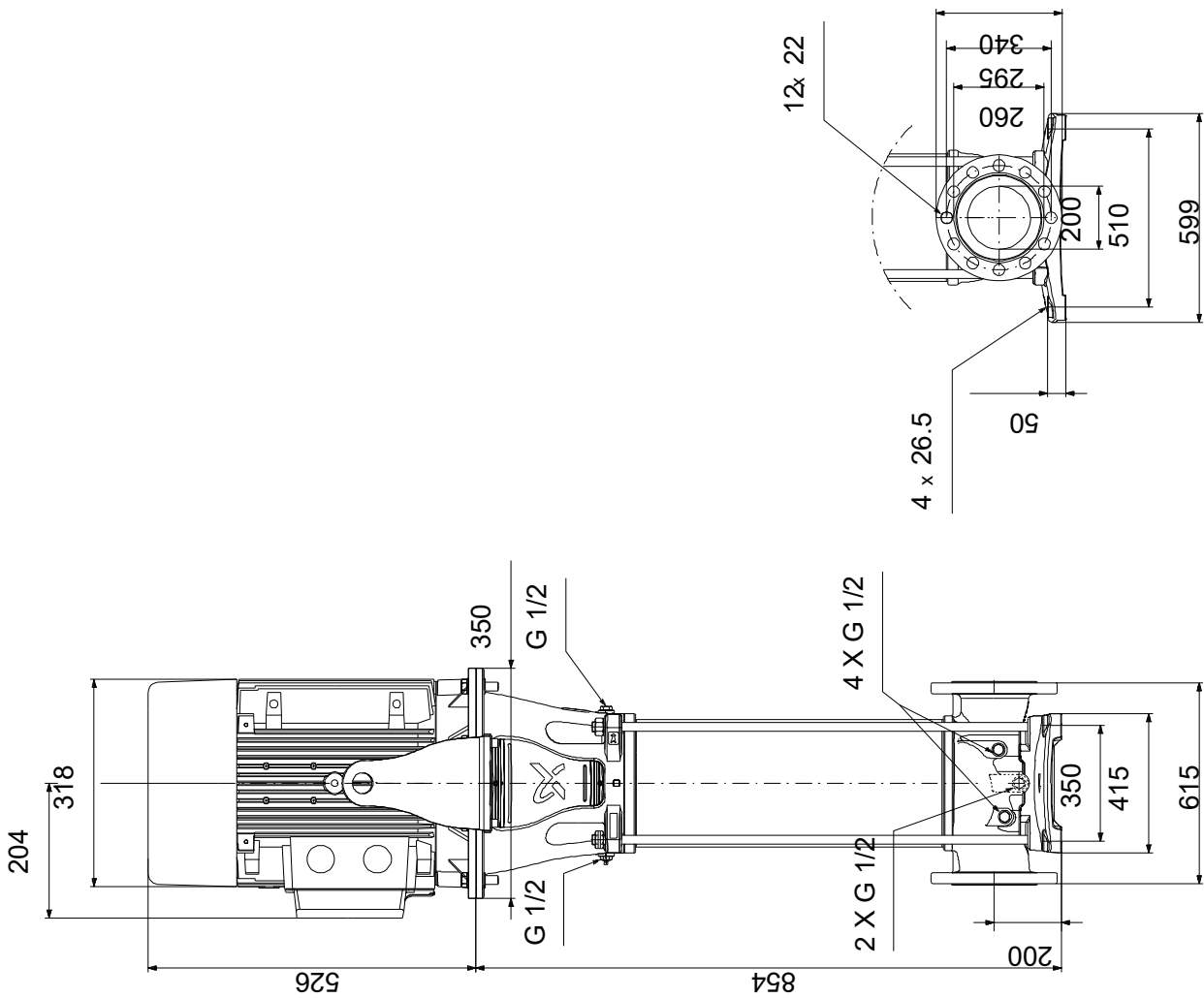

Note! All units are in [mm] unless others are stated.
Disclaimer: This simplified dimensional drawing does not show all details.

99143735 CRN 185-1-1 A-F-A-E-HQQE 50 Hz



IEC TP211 THERMALLY PROTECTED WHEN THE THERMISTORS ARE
CONNECTED TO AMPLIFIER RELAY FOR CONTROL OF MAIN SUPPLY
THERMISTORS PTC ACCORDING TO DIN 44082

Note! All units are in [mm] unless others are stated.

