

Qty.	Description
1	TPE3 D 32-180 S-A-F-A-BQQE-EAC
	
	<p>Note! Product picture may differ from actual product</p>
	<p>Product No.: On request</p>
	<p>Single-stage, close-coupled, volute twin-head pump with in-line suction and discharge ports of identical diameter. The twin-head pump is designed with two parallel power-heads.</p>
	<p>The pump is of the top-pull-out design, i.e. the power head (motor, pump head and impeller) can be removed for maintenance or service while the pump housing remains in the pipework.</p>
	<p>Each power head is fitted with an unbalanced rubber bellows seal.</p>
	<p>The shaft seal is according to EN 12756. Pipework connection is via PN 6/10 DIN flanges (EN 1092-2 and ISO 7005-2).</p>
	<p>Each power head is fitted with a fan-cooled, permanent-magnet synchronous motor of identical size. The motor efficiency is classified as IE5 in accordance with IEC 60034-30-2.</p>
	<p>The motor includes a frequency converter and PI controller in the motor terminal box. This enables continuously variable control of the motor speed, which again enables adaptation of the performance to a given requirement.</p>
	<p>The pump is fitted with a combined temperature- and differential pressure sensor.</p>
	<p>Controls:</p>
	<p>Frequency converter: Built-in</p>
	<p>Liquid:</p>
	<p>Pumped liquid: Water</p>
	<p>Liquid temperature range: -25 .. 120 °C</p>
	<p>Selected liquid temperature: 20 °C</p>
	<p>Density: 998.2 kg/m³</p>
	<p>Technical:</p>
	<p>Pump speed on which pump data are based: 4700 rpm</p>
	<p>Rated flow: 11.7 m³/h</p>
	<p>Rated head: 11.1 m</p>
	<p>Actual impeller diameter: 62 mm</p>
	<p>Code for shaft seal: BQQE</p>
	<p>Curve tolerance: ISO9906:2012 3B2</p>
	<p>Materials:</p>
	<p>Pump housing: Cast iron EN-GJL-250 ASTM class 35</p>
	<p>Impeller: Composite PES+30% GF</p>
	<p>Installation:</p>
	<p>Range of ambient temperature: -20 .. 50 °C</p>
	<p>Maximum operating pressure: 10 bar</p>
	<p>Max pressure at stated temp: 10 bar / 120 °C</p>
	<p>Type of connection: DIN</p>
	<p>Size of connection: DN 32</p>
	<p>Pressure rating for connection: PN 6/10</p>
	<p>Port-to-port length: 220 mm</p>
	<p>Flange size for motor: 56C</p>
	<p>Electrical data:</p>
	<p>Motor type: 71A</p>
	<p>IE Efficiency class: IE5</p>
	<p>Rated power - P2: 0.55 kW</p>

Qty.	Description																																		
1	<table> <tr> <td>Mains frequency:</td> <td>50 Hz</td> </tr> <tr> <td>Rated voltage:</td> <td>1 x 200-240 V</td> </tr> <tr> <td>Rated current:</td> <td>3.60-3.00 A</td> </tr> <tr> <td>Cos phi - power factor:</td> <td>0.96</td> </tr> <tr> <td>Rated speed:</td> <td>480-5900 rpm</td> </tr> <tr> <td>Efficiency:</td> <td>84.9%</td> </tr> <tr> <td>Motor efficiency at full load:</td> <td>84.9 %</td> </tr> <tr> <td>Enclosure class (IEC 34-5):</td> <td>IP55</td> </tr> <tr> <td>Insulation class (IEC 85):</td> <td>F</td> </tr> <tr> <td>Motor No:</td> <td>99138023</td> </tr> <tr> <td colspan="2">Others:</td> </tr> <tr> <td>Minimum efficiency index, MEI ≥:</td> <td>0.70</td> </tr> <tr> <td>Net weight:</td> <td>43.4 kg</td> </tr> <tr> <td>Gross weight:</td> <td>56.7 kg</td> </tr> <tr> <td>Shipping volume:</td> <td>0.252 m³</td> </tr> <tr> <td>Country of origin:</td> <td>HU</td> </tr> <tr> <td>Custom tariff no.:</td> <td>84137065</td> </tr> </table>	Mains frequency:	50 Hz	Rated voltage:	1 x 200-240 V	Rated current:	3.60-3.00 A	Cos phi - power factor:	0.96	Rated speed:	480-5900 rpm	Efficiency:	84.9%	Motor efficiency at full load:	84.9 %	Enclosure class (IEC 34-5):	IP55	Insulation class (IEC 85):	F	Motor No:	99138023	Others:		Minimum efficiency index, MEI ≥:	0.70	Net weight:	43.4 kg	Gross weight:	56.7 kg	Shipping volume:	0.252 m ³	Country of origin:	HU	Custom tariff no.:	84137065
Mains frequency:	50 Hz																																		
Rated voltage:	1 x 200-240 V																																		
Rated current:	3.60-3.00 A																																		
Cos phi - power factor:	0.96																																		
Rated speed:	480-5900 rpm																																		
Efficiency:	84.9%																																		
Motor efficiency at full load:	84.9 %																																		
Enclosure class (IEC 34-5):	IP55																																		
Insulation class (IEC 85):	F																																		
Motor No:	99138023																																		
Others:																																			
Minimum efficiency index, MEI ≥:	0.70																																		
Net weight:	43.4 kg																																		
Gross weight:	56.7 kg																																		
Shipping volume:	0.252 m ³																																		
Country of origin:	HU																																		
Custom tariff no.:	84137065																																		

Description	Value
General information:	
Product name:	TPE3 D 32-180 S-A-F-A-BQQE-EAC
Product No:	On request
EAN number:	On request
Technical:	
Pump speed on which pump data are based:	4700 rpm
Rated flow:	11.7 m ³ /h
Rated head:	11.1 m
Maximum head:	180 dm
Actual impeller diameter:	62 mm
Code for shaft seal:	BQQE
Curve tolerance:	ISO9906:2012 3B2
Pump version:	A
Materials:	
Pump housing:	Cast iron
Pump housing:	EN-GJL-250
Pump housing:	ASTM class 35
Impeller:	Composite
Impeller:	PES+30% GF
Material code:	A
Installation:	
Range of ambient temperature:	-20 .. 50 °C
Maximum operating pressure:	10 bar
Max pressure at stated temp:	10 bar / 120 °C
Type of connection:	DIN
Size of connection:	DN 32
Pressure rating for connection:	PN 6/10
Port-to-port length:	220 mm
Flange size for motor:	56C
Connect code:	F
Liquid:	
Pumped liquid:	Water
Liquid temperature range:	-25 .. 120 °C
Selected liquid temperature:	20 °C
Density:	998.2 kg/m ³
Electrical data:	
Motor type:	71A
IE Efficiency class:	IE5
Rated power - P2:	0.55 kW
Mains frequency:	50 Hz
Rated voltage:	1 x 200-240 V
Rated current:	3.60-3.00 A
Cos phi - power factor:	0.96
Rated speed:	480-5900 rpm
Efficiency:	84.9%
Motor efficiency at full load:	84.9 %
Enclosure class (IEC 34-5):	IP55
Insulation class (IEC 85):	F
Built-in motor protection:	ELEC
Motor No:	99138023
Controls:	
Control panel:	HMI300 - Graphical
Function Module:	FM300 - Advanced
Frequency converter:	Built-in
Others:	
Minimum efficiency index, MEI ≥:	0.70
Net weight:	43.4 kg
Gross weight:	56.7 kg
Shipping volume:	0.252 m ³
Config. file no:	98481452
Country of origin:	HU
Custom tariff no.:	84137065

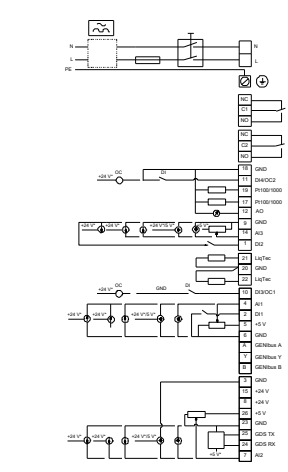
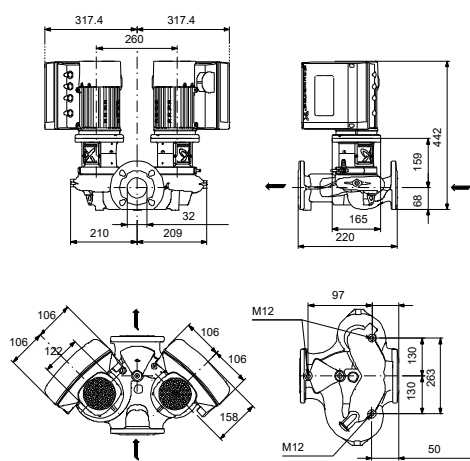
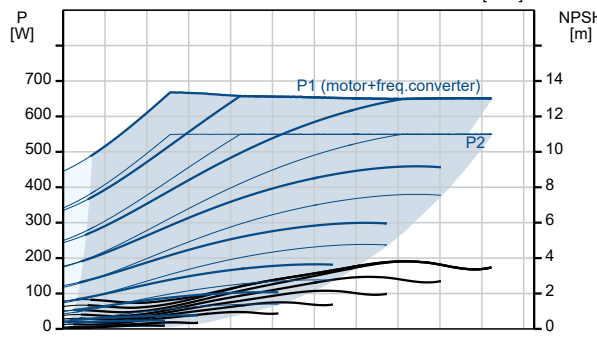
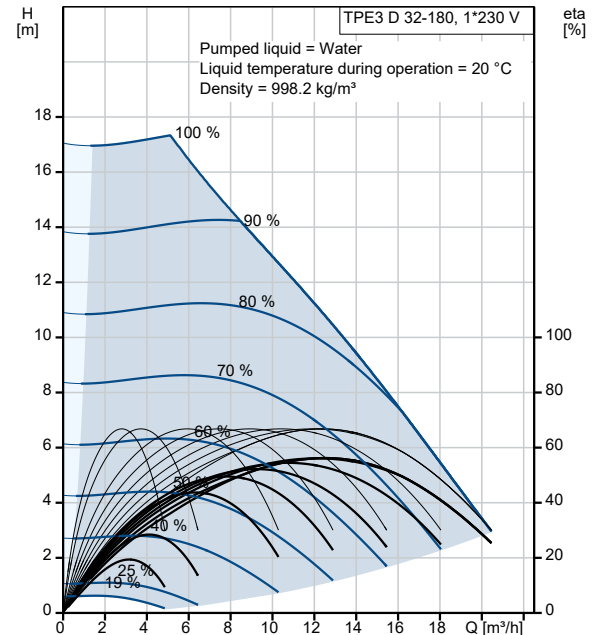

On request TPE3 D 32-180 S-A-F-A-BQQE-EAC 50 Hz

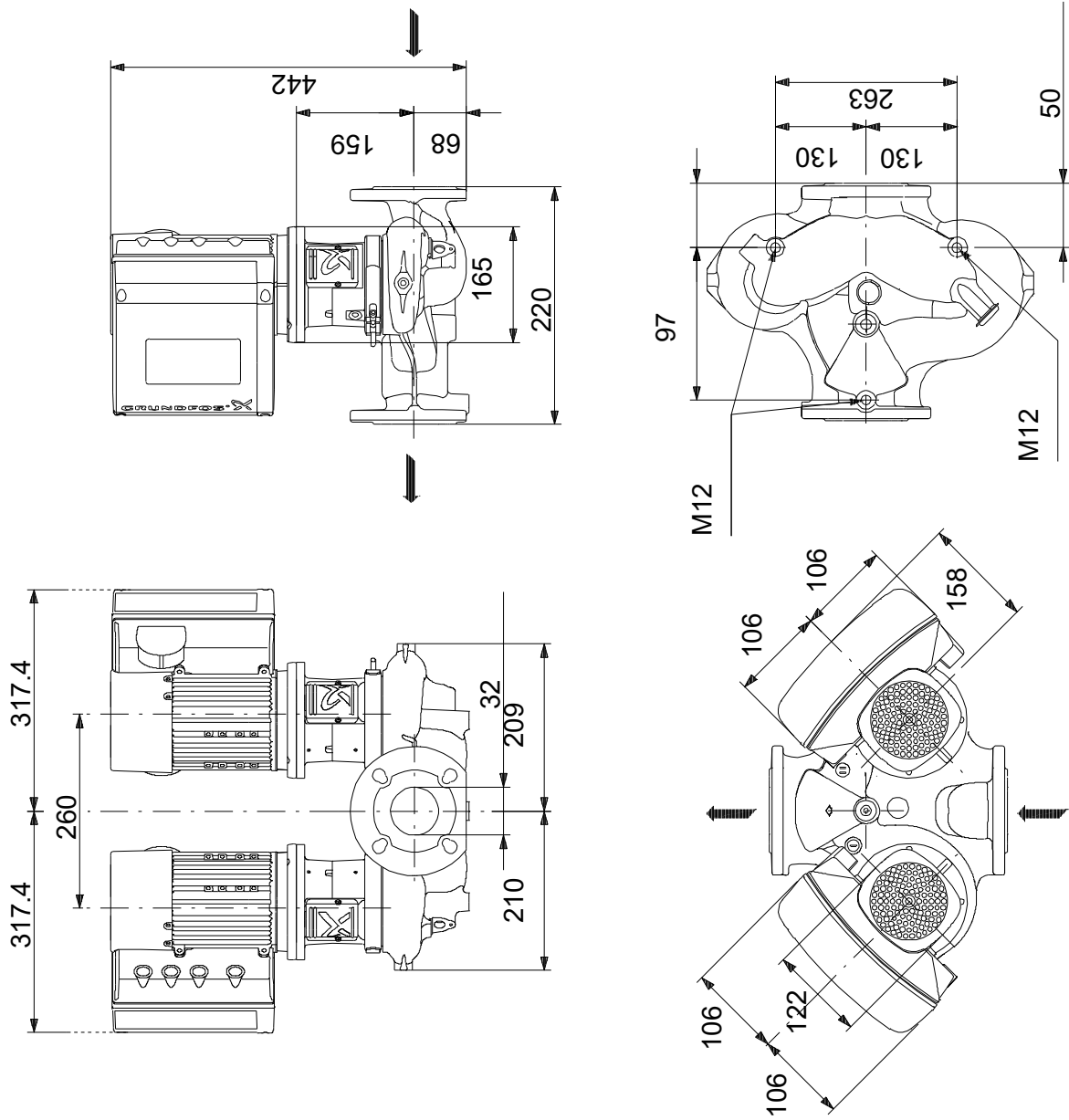

Note! All units are in [mm] unless others are stated.
 Disclaimer: This simplified dimensional drawing does not show all details.

