

Qty.	Description
------	-------------

1	SEG.50.40.EX.2.50B
---	---------------------------



Note! Product picture may differ from actual product

Product No.: [99274389](#)

Grundfos SEG grinder pumps are non-self-priming, single-stage, centrifugal pumps with horizontal discharge port, specifically designed for pumping wastewater containing discharge from toilets. The pump is equipped with a grinder system that grinds destructible solids into small pieces to lead them through pipes with a relatively small diameter.

SEG grinder pumps are ideal for use in sparsely populated areas, where gravity sewage systems are not available. Examples include villages, farm areas and areas with large terrain-level differences, where a pressurised system has advantages.

The pump is available for two types of installation:

- submerged installation on auto-coupling systems
- submerged installation, free-standing.

The pump is made of wear-resistant materials, such as cast iron and stainless steel.

These materials ensure reliable operation.

The surface of the pump is smooth to prevent dirt and impurities from sticking.

The corrosion-resistant stainless steel clamp is securing the motor to the pump housing and allow the easy service of the pump.

SmartTrim system allows easy adjustment of the impeller clearance to ensure maximum efficiency during the pump lifespan.

The range is designed to reduce energy consumption and keep downtime costs to a minimum, while maintaining peak performance throughout the lifespan of the system.

The pump is explosion-proof.

Further product details

This grinder pump is specially designed for pumping effluent and untreated domestic sewage in areas with no sewer system or where gravitation systems are unsuitable.

The pump is designed for transfer of domestic and municipal wastewater:

- in sparsely populated areas
- in small villages and farms
- in areas of difficult topography
- in areas with high groundwater

The pump can also remove industrial wastewater containing fibres in industrial applications, such as washing plants.

Pump

The pump is primarily made of cast iron with surface treatment of powder coating: black NCS9000N/RAL 9005, gloss 30, thickness 100 µ.

The pump features a patented grinder system, ensuring extremely high efficiency and reliable operation. Quick and easy dismantling for replacement of wear parts. No special tools are required.

Qty. Description

1



A stainless-steel clamp connection between motor and pump housing ensures easy inspection and service of the impeller and shaft seal.

The shaft seal consists of a double cartridge seal that ensures a reliable sealing between the pumped liquid and motor.

- Primary seal: silicon carbide/silicon carbide (SiC/SiC) mechanical shaft seal
- Secondary seal: carbon/aluminium oxide mechanical shaft seal

This pump is equipped with the unique SmartTrim system that enables you to easily restore the factory-set impeller clearance and maintain peak pumping efficiency.

To do this, remove the cutter head and adjust the SmartTrim nut on the impeller.

This can be done on site without dismantling the pump and without using special tools.

The pump has been tested and approved by VDE. Furthermore, the pump is approved for installation in explosive atmospheres and holds the following examination certificate:

- KEMA 06ATEX0127X
- IECEX KEM 06 0028X

Both certificates have been issued by KEMA according to the ATEX directive (94/9/EC).

Note: Explosion-proof pumps must always be fully submerged.

Motor

The motor is a watertight, totally encapsulated motor, supplied with a 10 m power cable.

The stainless-steel plug is fastened with a union nut.

This nut and O-rings provide sealing against ingress of the liquid.

The plug is polyurethane-embedded, ensuring a watertight and durable seal around the leads of the cable.

This prevents the ingress of water into the motor through the cable in case of cable breakage or adverse handling in connection with installation or service.

The motor construction is compact with a short shaft. This reduces vibrations, resulting in an increased efficiency and life of the shaft seal and ball bearings. The motor has two thermal switches in the motor windings to protect the motor against overheating.

Controls:

Moisture sensor: without moisture sensors

AUTOADAPT: NO

Liquid:

Liquid temperature range: 0 .. 40 °C

Density: 998.2 kg/m³

Technical:

Max flow: 10.3 l/s

Type of impeller: Grinder system

Primary shaft seal: SiC/SiC

Approvals on nameplate: PA-I, ATEX

Curve tolerance: ISO9906:2012 3B2

Materials:

Pump housing: Cast iron
EN1561 EN-GJL-200

Impeller: Cast iron
EN1561 EN-GJL-200

Qty.	Description
1	<p>Installation:</p> <p>t max amb: 40 °C</p> <p>Maximum operating pressure: 6 bar</p> <p>Flange standard: DIN</p> <p>Pipework connection: DN 50</p> <p>Pump outlet: DN 50</p> <p>Pressure rating: PN 10</p> <p>Maximum installation depth: 10 m</p> <p>Auto-coupling: 97695874</p> <p>Electrical data:</p> <p>Power input - P1: 4.9 kW</p> <p>Rated power - P2: 4 kW</p> <p>Mains frequency: 50 Hz</p> <p>Rated voltage: 3 x 400-415 V</p> <p>Voltage tolerance: +6/-10 %</p> <p>Max starts per. hour: 30</p> <p>Rated current: 8 A</p> <p>Starting current: 43 A</p> <p>Rated current at no load: 3.5 A</p> <p>Cos phi - power factor: 0.92</p> <p>Cos phi - p.f. at 3/4 load: 0.89</p> <p>Cos phi - p.f. at 1/2 load: 0.81</p> <p>Rated speed: 2830 rpm</p> <p>Moment of inertia: 0.011 kg m²</p> <p>Motor efficiency at full load: 82 %</p> <p>Motor efficiency at 3/4 load: 82 %</p> <p>Motor efficiency at 1/2 load: 80 %</p> <p>Number of poles: 2</p> <p>Start. method: direct-on-line</p> <p>Enclosure class (IEC 34-5): IP68</p> <p>Insulation class (IEC 85): F</p> <p>Explosion proof: yes</p> <p>Ex-description: II2G EXDB IIBT4/T3GB</p> <p>Explosion protection standard: EN 60079-0/EN 60079-1</p> <p>Length of cable: 10 m</p> <p>Cable type: LYNIFLEX</p> <p>Type of cable plug: No plug</p> <p>Others:</p> <p>Net weight: 71.7 kg</p> <p>Danish VVS No.: 391342492</p>

99274389 SEG.50.40.EX.2.50B 50 Hz

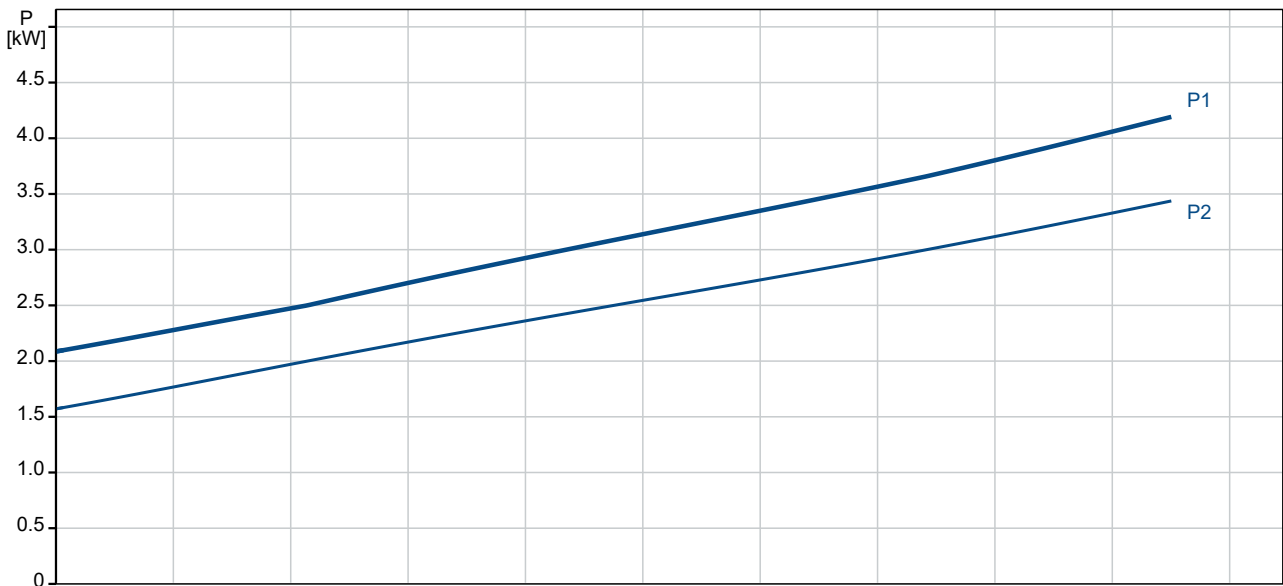
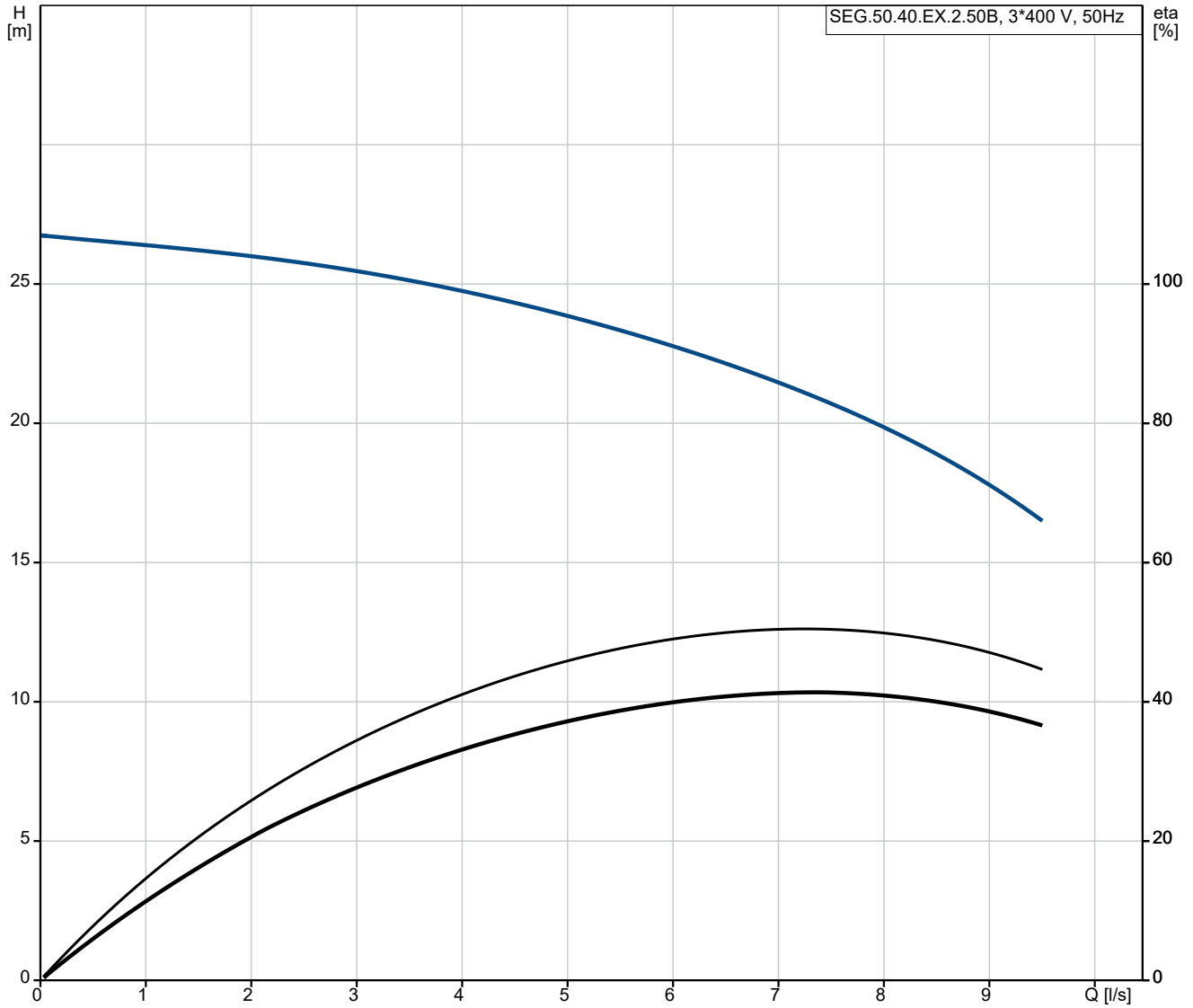

Description	Value
General information:	
Product name:	SEG.50.40.EX.2.50B
Product No:	99274389
EAN number:	5713826395841
Technical:	
Max flow:	10.3 l/s
Head max:	26.8 m
Type of impeller:	Grinder system
Primary shaft seal:	SIC/SIC
Approvals on nameplate:	PA-I, ATEX
Curve tolerance:	ISO9906:2012 3B2
Materials:	
Pump housing:	Cast iron
Pump housing:	EN1561 EN-GJL-200
Impeller:	Cast iron
Impeller:	EN1561 EN-GJL-200
Installation:	
t max amb:	40 °C
Maximum operating pressure:	6 bar
Flange standard:	DIN
Pipework connection:	DN 50
Pump outlet:	DN 50
Pressure rating:	PN 10
Maximum installation depth:	10 m
Inst dry/wet:	SUBMERGED
Auto-coupling:	97695874
Liquid:	
Liquid temperature range:	0 .. 40 °C
Density:	998.2 kg/m ³
Electrical data:	
Power input - P1:	4.9 kW
Rated power - P2:	4 kW
Mains frequency:	50 Hz
Rated voltage:	3 x 400-415 V
Voltage tolerance:	+6/-10 %
Max starts per. hour:	30
Rated current:	8 A
Starting current:	43 A
Rated current at no load:	3.5 A
Cos phi - power factor:	0.92
Cos phi - p.f. at 3/4 load:	0.89
Cos phi - p.f. at 1/2 load:	0.81
Rated speed:	2830 rpm
Moment of inertia:	0.011 kg m ²
Motor efficiency at full load:	82 %
Motor efficiency at 3/4 load:	82 %
Motor efficiency at 1/2 load:	80 %
Number of poles:	2
Start. method:	direct-on-line
Enclosure class (IEC 34-5):	IP68
Insulation class (IEC 85):	F
Explosion proof:	yes
Ex-description:	II2G EXDB IIBT4/T3GB
Explosion protection standard:	EN 60079-0/EN 60079-1
Built-in motor protection:	THERMAL SWITCH
Thermal protec:	external
Length of cable:	10 m
Cable type:	LYNIFLEX

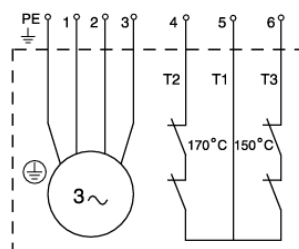
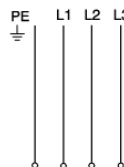
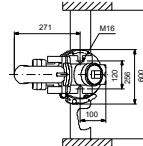
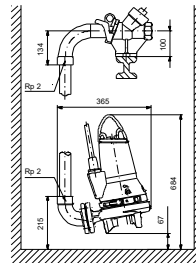
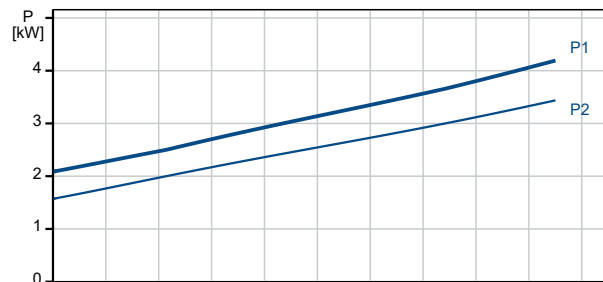
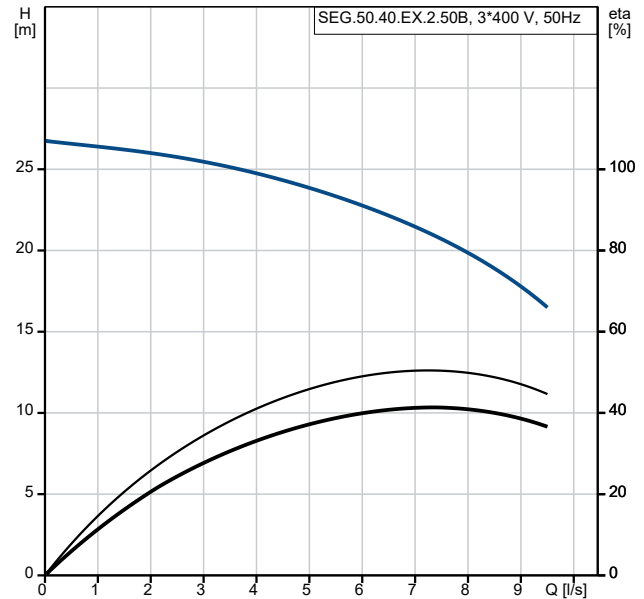



Company name:

Created by:

Phone:

Date:

17/11/2022

Description	Value
Type of cable plug:	No plug
Controls:	
Control box:	not included
Additional I/O:	External
Moisture sensor:	without moisture sensors
AUTOADAPT:	NO
Others:	
Net weight:	71.7 kg
Danish VVS No.:	391342492

99274389 SEG.50.40.EX.2.50B 50 Hz

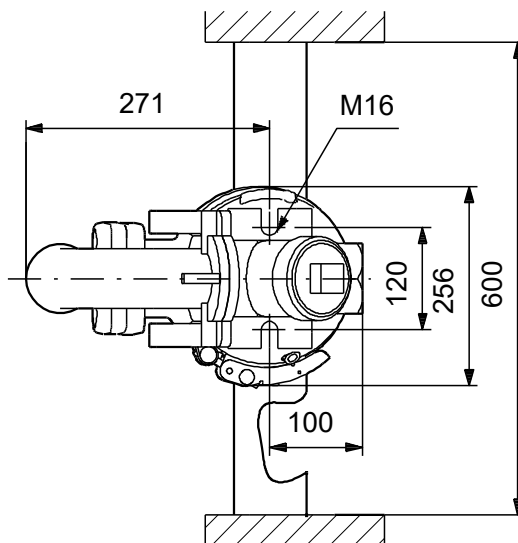
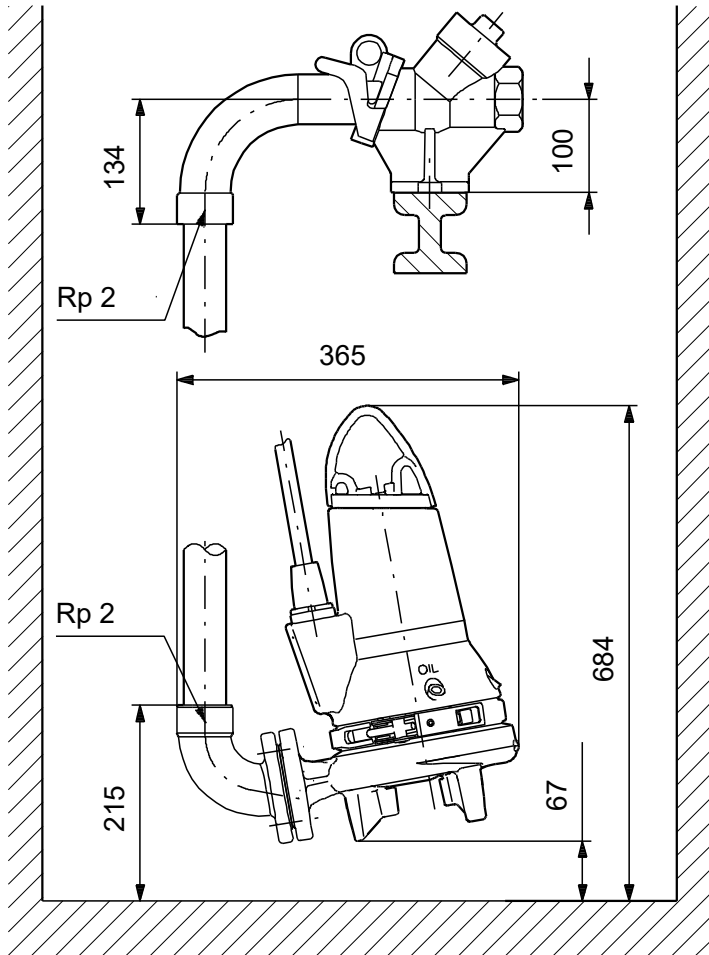

Note! All units are in [mm] unless others are stated.
Disclaimer: This simplified dimensional drawing does not show all details.

99274389 SEG.50.40.EX.2.50B 50 Hz

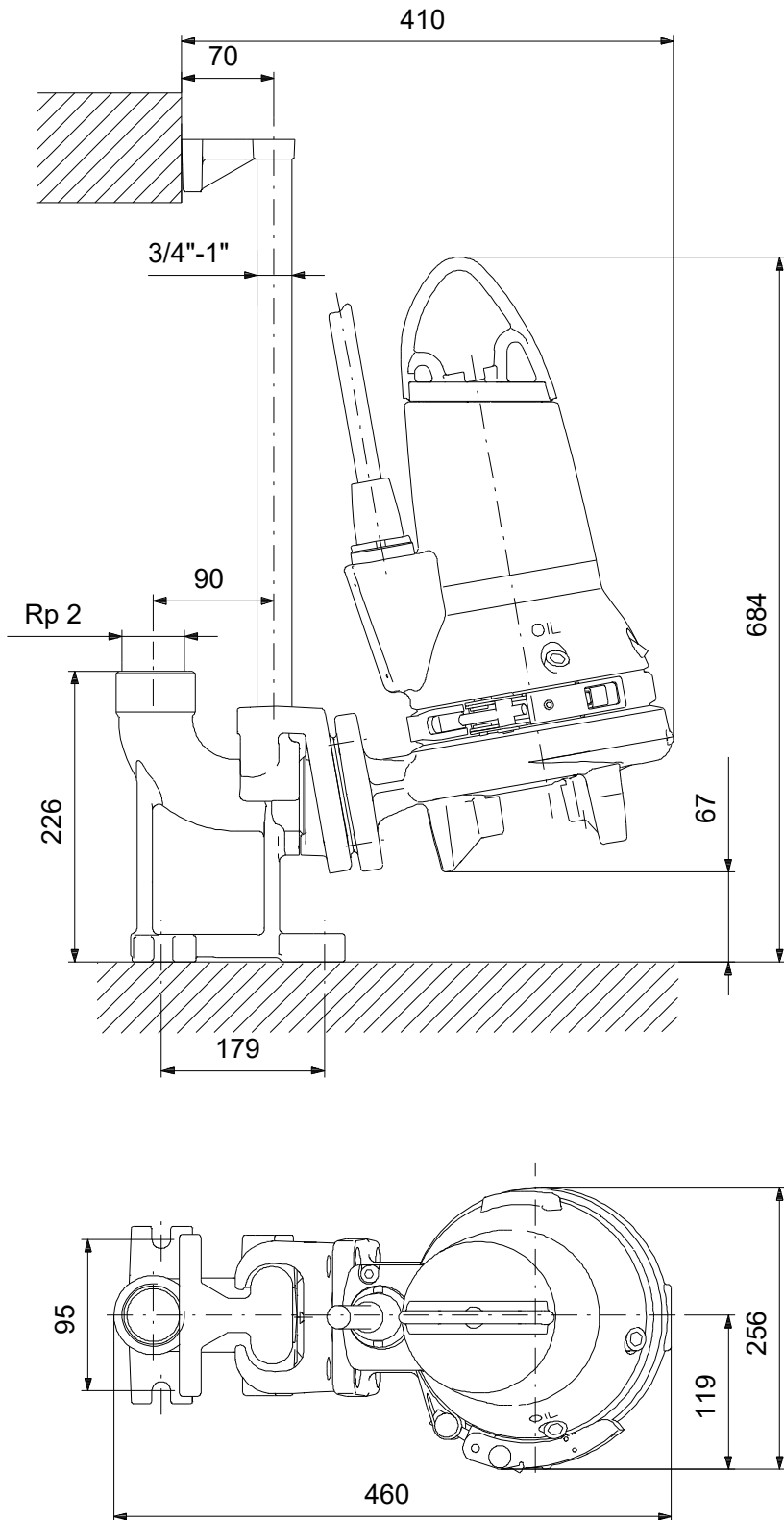

Note! All units are in [mm] unless others are stated.
Disclaimer: This simplified dimensional drawing does not show all details.

99274389 SEG.50.40.EX.2.50B 50 Hz

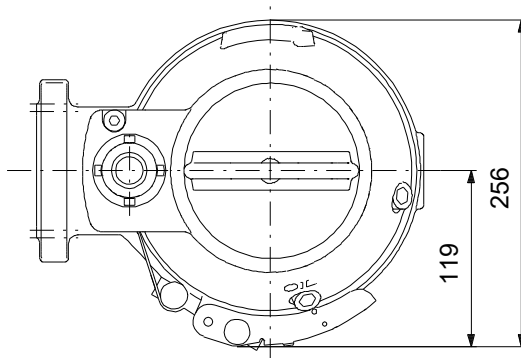
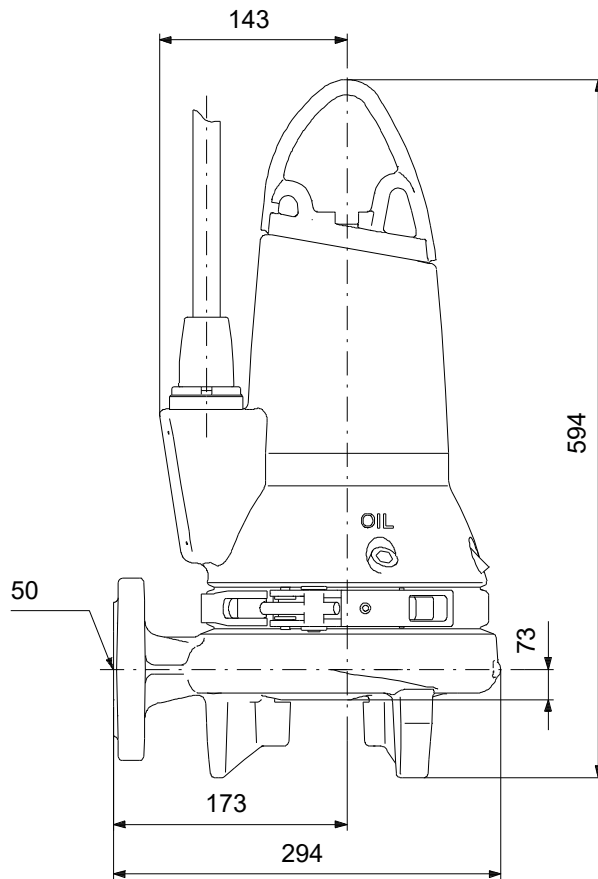

Note! All units are in [mm] unless others are stated.
Disclaimer: This simplified dimensional drawing does not show all details.

99274389 SEG.50.40.EX.2.50B 50 Hz

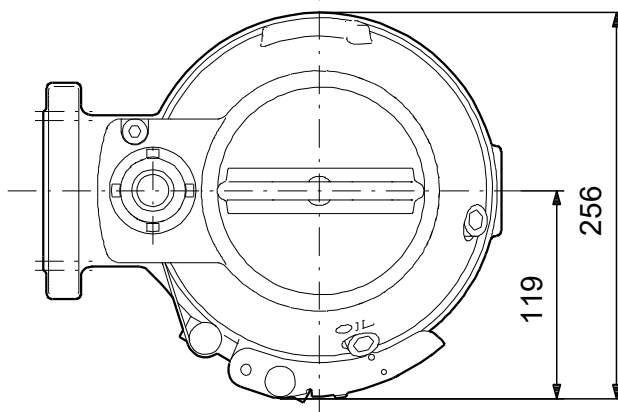
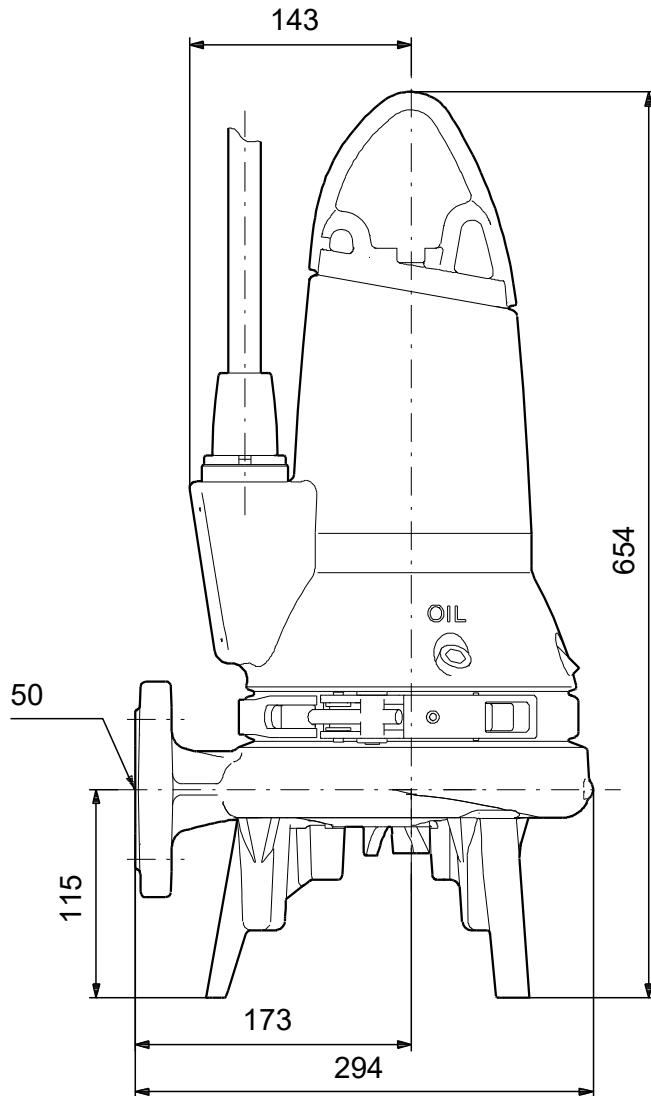

Note! All units are in [mm] unless others are stated.
Disclaimer: This simplified dimensional drawing does not show all details.

99274389 SEG.50.40.EX.2.50B 50 Hz

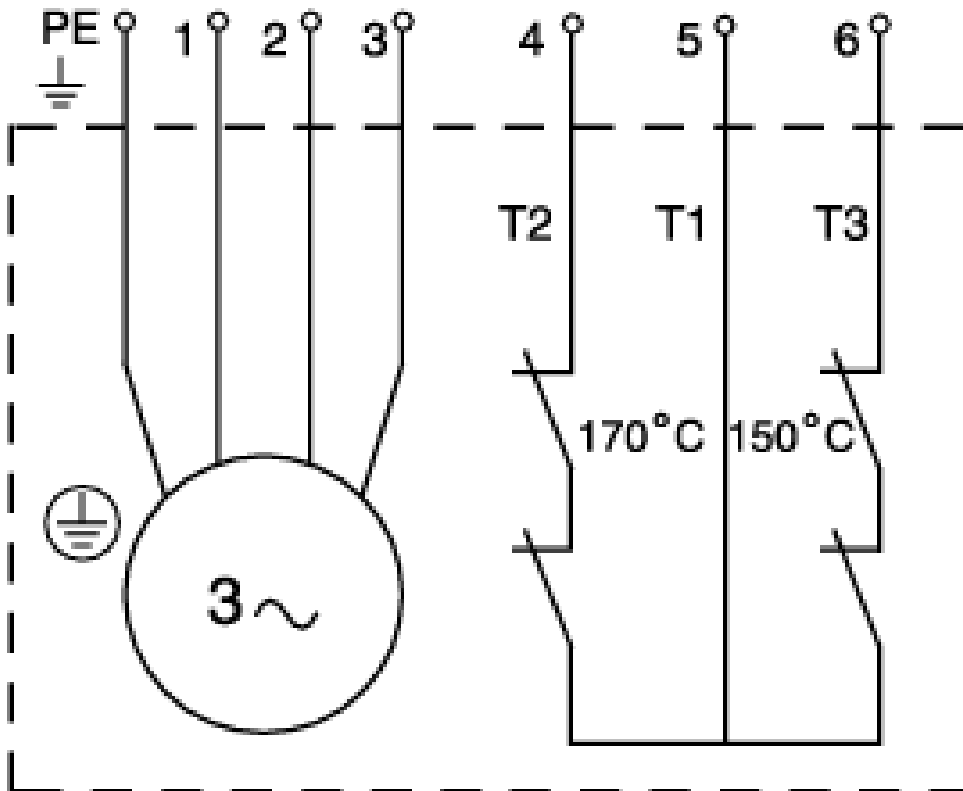
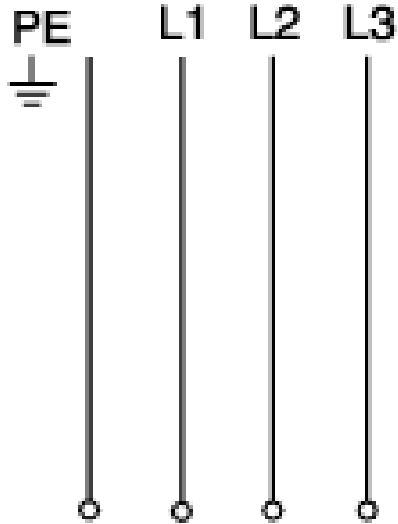

Note! All units are in [mm] unless others are stated.



Company name:

Created by:

Phone:

Date:

17/11/2022

Order Data:

Position	Your pos.	Product name	Amount	Product No	Total
		SEG.50.40.EX.2.50B	1	99274389	Price on request