

Qty.	Description
1	<p data-bbox="199 338 534 367">CUE 3X380-500V IP20 1,1KW</p> <div data-bbox="316 421 470 667" style="text-align: center;">  </div> <p data-bbox="592 683 1064 707" style="text-align: center;">Note! Product picture may differ from actual product</p> <p data-bbox="199 714 478 741">Product No.: On request</p> <p data-bbox="199 775 1430 851">CUE is a complete range of external frequency converters designed for speed control of a wide range of Grundfos pumps. CUE has a built-in PI controller and offers the same functionality and user-interface as Grundfos E-pumps. CUE solutions can thus be seen as an extension to the E-pump range.</p> <p data-bbox="199 860 876 887">By choosing a CUE-solution, you will get the following benefits:</p> <ul data-bbox="237 889 1192 1066" style="list-style-type: none"> - Grundfos E-pump functionality and user-interface - application- and pump-family-related functions - increased comfort compared to fixed-speed pumps - very easy installation and commissioning compared to standard frequency converters - speed control of pumps up to 250 kW - speed control of pumps installed in potentially explosive environments. <p data-bbox="199 1068 662 1095">CUE offers the following inputs and output:</p> <ul data-bbox="237 1097 1023 1245" style="list-style-type: none"> - RS-485 GENIbus - an analog 0-10 V input for external setpoint - an analog 0/4-20 mA input for sensor - four digital inputs for various functions, for instance external start/stop - two signal relays (C/NO/NC). <p data-bbox="199 1274 341 1301">Accessories:</p> <p data-bbox="199 1303 483 1330">Input/output add-on board</p> <p data-bbox="199 1332 475 1359">Provides additional input:</p> <ul data-bbox="237 1361 1192 1451" style="list-style-type: none"> - one 0/4-20 mA analog input for an additional sensor - one 0-20 mA analog output - two inputs for Pt100/Pt1000 temperature sensors, for instance for bearing monitoring. <p data-bbox="199 1482 338 1509">Motor filters:</p> <p data-bbox="199 1512 1441 1565">For reduction of dU/dt and peak voltages to the motor windings and for reduction of the acoustic noise generated in the motor, a number of motor filters are offered:</p> <ul data-bbox="237 1568 612 1628" style="list-style-type: none"> - dU/dt filters , 11-250 kW - Sine wave filters, 0.55-250 kW. <p data-bbox="199 1659 316 1686">Technical:</p> <p data-bbox="199 1688 791 1715">Approvals on nameplate: CE, CULUS, C-TICK</p> <p data-bbox="199 1747 327 1774">Installation:</p> <p data-bbox="199 1776 670 1803">Range of ambient temperature: 0 .. 50 °C</p> <p data-bbox="199 1805 644 1832">Relative humidity: 5-95 %</p> <p data-bbox="199 1863 363 1890">Electrical data:</p> <p data-bbox="199 1892 644 1919">Rated power - P2: 1.1 kW</p> <p data-bbox="199 1921 679 1948">Mains frequency: 50 / 60 Hz</p> <p data-bbox="199 1951 813 1977">Rated voltage [V]: 3 x 380-440/441-500 V</p> <p data-bbox="199 1980 647 2007">Rated current: 3-2.7 A</p> <p data-bbox="199 2009 604 2036">Maximum current consumption: 3 A</p> <p data-bbox="199 2038 624 2065">Efficiency at full load: 96 %</p> <p data-bbox="199 2067 617 2094">Enclosure class (IEC 34-5): IP20</p>



Company name:

Created by:

Phone:

Date:

17/06/2022

Qty.	Description
------	-------------

	Others: Net weight: 4.9 kg Danish VVS No.: 382995011
--	--

Description	Value
General information:	
Product name:	CUE 3X380-500V IP20 1,1KW
Product No:	On request
EAN number:	On request
Technical:	
Approvals on nameplate:	CE, CULUS, C-TICK
Installation:	
Range of ambient temperature:	0 .. 50 °C
Relative humidity:	5-95 %
Mounted on:	Wall
Electrical data:	
Rated power - P2:	1.1 kW
Mains frequency:	50 / 60 Hz
Rated voltage [V]:	3 x 380-440/441-500 V
Rated current:	3-2.7 A
Maximum current consumption:	3 A
Efficiency at full load:	96 %
Enclosure class (IEC 34-5):	IP20
Built-in motor protection:	YES
Thermal protec:	external
Cable length:	150/300 m
Others:	
Net weight:	4.9 kg
Danish VVS No.:	382995011

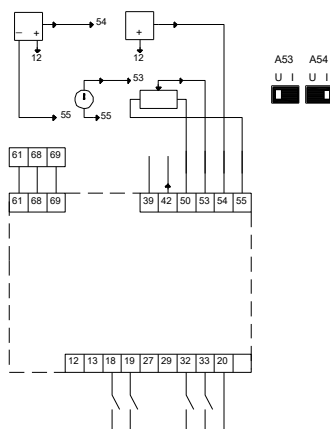
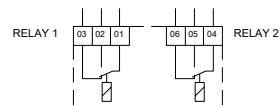
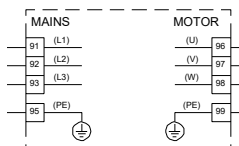
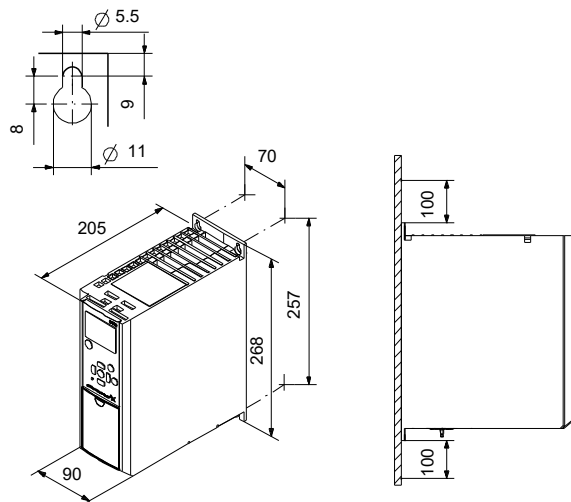

On request CUE 3X380-500V IP20 1,1KW

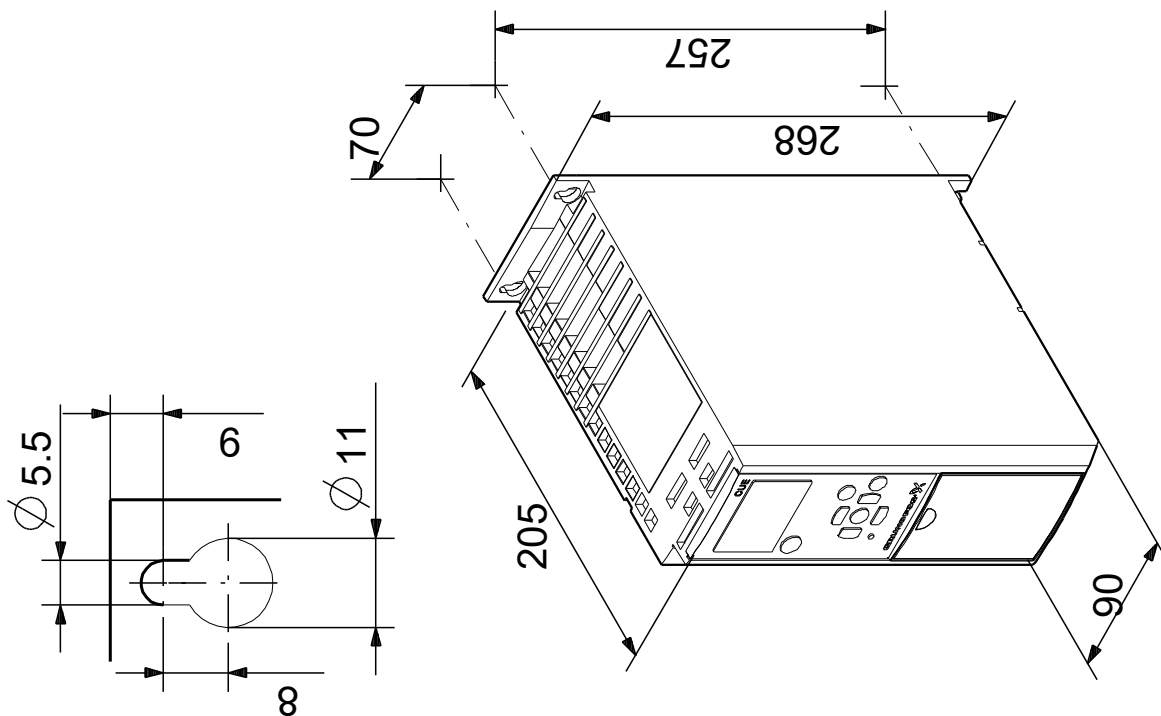
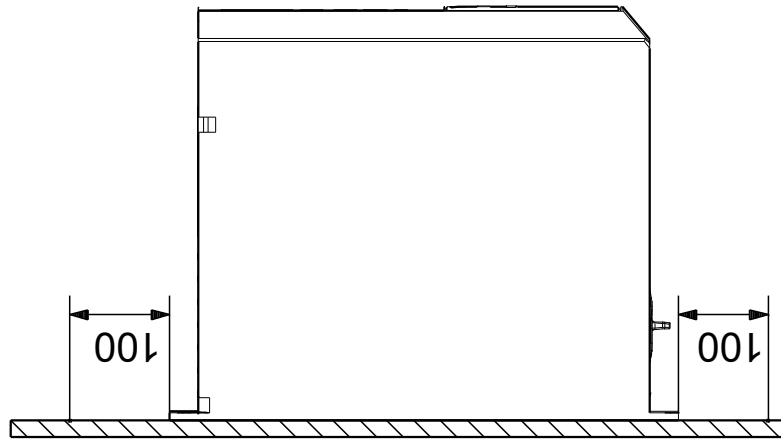

Note! All units are in [mm] unless others are stated.
Disclaimer: This simplified dimensional drawing does not show all details.



Company name:

Created by:

Phone:

Date:

17/06/2022

Order Data:

Product name: CUE 3X380-500V IP20 1,1KW

Amount: 1

Product No: On request

Total: Price on request
