

Clarke®

PUMP



1" WATER PUMPS

Models SPE800 & SPE1200SS

Part No: 7237000 & 7237002

OPERATING & MAINTENANCE INSTRUCTIONS



GC1110

INTRODUCTION

Thank you for purchasing this CLARKE Water Pump.

Before attempting to operate the pump, it is essential that you read this manual thoroughly and carefully follow all instructions given. In doing so you will ensure the safety of yourself and that of others around you, and you can also look forward to the pump giving you long and satisfactory service.

GUARANTEE

This CLARKE product is guaranteed against faulty manufacture for a period of 12 months from the date of purchase. Please keep your receipt as proof of purchase.

This guarantee is invalid if the product is found to have been abused or tampered with in any way, or not used for the purpose for which it was intended.

Faulty goods should be returned to their place of purchase, no product can be returned to us without prior permission.

This guarantee does not effect your statutory rights.

ENVIRONMENTAL PROTECTION



Do not dispose of this product with general household waste. All tools, accessories and packaging should be sorted, taken to a recycling centre and disposed of appropriately.

PARTS & SERVICE

For parts & Servicing, please contact your nearest dealer, or CLARKE International, on one of the following numbers.

PARTS & SERVICE TEL: 020 8988 7400

PARTS & SERVICE FAX: 020 8558 3622

or e-mail as follows:

PARTS: Parts@clarkeinternational.com

SERVICE: Service@clarkeinternational.com

CONTENTS

| | |
|----------------------------------|----|
| Introduction | 2 |
| Guarantee | 2 |
| Environmental Protection | 2 |
| Parts & Service Contacts | 2 |
| Table of Contents | 3 |
| Description | 3 |
| General Safety Precautions | 4 |
| Electrical Connections | 6 |
| Preparation for Use | 7 |
| Maintenance | 10 |
| Troubleshooting | 11 |
| Parts Lists and Diagrams | 13 |
| Technical Specification | 17 |
| Declarations of Conformity | 18 |

DESCRIPTION

The SPE800 and SPE1200SS are centrifugal, horizontal electric pumps with a self-priming capability and venturi system, suitable for pumping water from a depth of up to 8 m.

They are designed to operate with clean water only, at a max temp of 35°C. Operating with contaminated or salt water should be avoided. The pump inlet is higher than the impeller inlet so that it can start operating when only the pump body is filled with water.

Upon receipt, any damage or deficiency should be reported to your CLARKE dealer immediately.

GENERAL SAFETY PRECAUTIONS



As with all machinery, there are certain hazards involved with its operation and use. Exercising caution will reduce the risk of personal injury.

WORK AREA

1. **Keep the work area clean and well lit.** Floors should always be kept clear. Cluttered or dark areas invite accidents.
2. **Keep children and bystanders away while operating machines.** Distractions can cause loss of control.

PERSONAL SAFETY

1. **ALWAYS stay alert, watch what you are doing and use common sense when operating this pump.** Do not use the pump while you are tired or under the influence of medication, drugs or alcohol. A moment of inattention can result in personal injury.
2. **Do not over-reach.** Keep your proper footing and balance at all times when positioning the pump.
3. **NEVER** direct the water discharge towards electrical wiring or equipment.
4. **ALWAYS** store the pump out of reach of children and do not allow persons unfamiliar with these instructions to operate it.
5. **NEVER** direct the discharge flow towards another person.
6. **ALWAYS** thoroughly familiarise yourself with this pump & its operation, and follow all instructions in this manual.
7. **ALWAYS** ensure that the pump is properly positioned where necessary to prevent it from moving during operation, and that the immediate area surrounding the pump is kept clear.

GENERAL EQUIPMENT USE AND CARE



WARNING: The SPE800 & SPE1200SS pumps are not submersible pumps. On no account should they ever be immersed in water.

1. **ALWAYS** maintain the pump with care and keep it clean for best / safest performance.
2. **NEVER** use this pump if any part is damaged. Have it inspected and repaired by your local Clarke dealer. Always turn the pump off before carrying out any maintenance.
3. **NEVER** modify this pump in any way. Use it **ONLY** for the purpose for which it is designed.

4. **NEVER** run the pump dry. Always ensure the pump is filled or ready to be filled with water before starting.
5. **NEVER** overtighten drain or filler plugs. Excessive force may damage the threads and make the plug difficult to remove in future.
6. **ALWAYS** ensure the pump is in a horizontal position and is firmly anchored via its fixing screws to a level surface.
7. **NEVER** use for pumping flammable liquids or corrosive chemicals. These pumps are designed to pump **WATER ONLY**.
8. **ALWAYS** use a strainer connected to the suction (inlet) hose, to prevent stones and other debris from being drawn up, which could cause severe damage to the pump.

SERVICING

1. **ALWAYS** have the pump serviced by your local CLARKE dealer, using only identical replacement parts. This will ensure the safety of the pump is maintained. The use of non standard parts could be hazardous.
2. **NEVER** attempt any repairs yourself. If you have a problem with this product contact your local CLARKE dealer.

Your CLARKE water pump has been designed to give long and trouble free service. If, however, having followed the instructions in this booklet carefully, you encounter problems, take the unit to your local CLARKE dealer.

ELECTRICAL CONNECTIONS



WARNING! Read these electrical safety instructions thoroughly before connecting the product to the mains supply.

Before switching the product on, make sure that the voltage of your electricity supply is the same as that indicated on the rating plate. This product is designed to operate on 230VAC 50Hz. Connecting it to any other power source may cause damage.

This product may be fitted with a non-rewireable plug. If it is necessary to change the fuse in the plug, the fuse cover must be refitted. If the fuse cover becomes lost or damaged, the plug must not be used until a suitable replacement is obtained.

If the plug has to be changed because it is not suitable for your socket, or due to damage, it should be cut off and a replacement fitted, following the wiring instructions shown below. The old plug must be disposed of safely, as insertion into a mains socket could cause an electrical hazard.



WARNING! The wires in the power cable of this product are coloured in accordance with the following code:

Blue = Neutral

Brown = Live

Yellow & Green = Earth

If the colours of the wires in the power cable of this product do not correspond with the terminal markings of your plug, proceed as follows:

- The wire which is coloured Blue must be connected to the terminal which is marked N or coloured Black.
- The wire which is coloured Brown must be connected to the terminal which is marked L or coloured Red.
- The wire which is coloured Yellow & Green must be connected to the terminal which is marked E or  or coloured Green.

Plug must be BS1363/A approved

Earth
(Green and Yellow)

Neutral
(Blue)

Always fit a 13 Amp fuse.

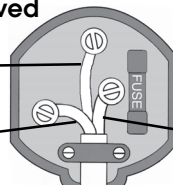

Live
(Brown)

Ensure that the outer sheath of the cable is firmly held by the clamp

We strongly recommend that this machine is connected to the mains supply via a Residual Current Device (RCD)

If in any doubt, consult a qualified electrician. DO NOT attempt any repairs yourself.

PREPARATION FOR USE

Because of the variety of possible installations, no plumbing accessories are supplied with your pump, however accessories designed specifically for this range of pumps are available from your nearest CLARKE dealer. Contact your CLARKE dealer for further information, or CLARKE International Sales Department on 01992 565333.

IMPORTANT: The pump MUST NOT be connected to the mains power supply until all hose/pipe installation is completed.

POSITIONING THE PUMP

A typical installation of the pump is shown in Fig 1. Connect the suction and discharge hoses to the pump housing to achieve an air-tight seal. Ensure there is no damage to the hoses which must be well protected and supported.

The pump must always be installed and operated in a horizontal position i.e. with the outlet port facing vertically upwards. The fixing holes in the base should be used to secure the pump firmly in its operating position. Always ensure there is adequate air circulation around the motor.

Avoid situations where the pump could become drenched with water. Neither the motor or terminal box are designed to be waterproof.

Position the pump as near to the water source as possible.

Ensure there is adequate drainage and there is no risk of damage to property as a result of water being discharged.

A foot valve/filter should be fitted to the lower end of the suction hose, as illustrated in Fig 2, in order to retain water in the suction system and more importantly, to prevent the possibility of large objects entering the pump body.

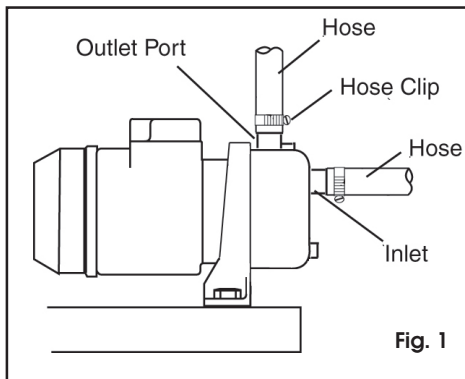

Fig. 1

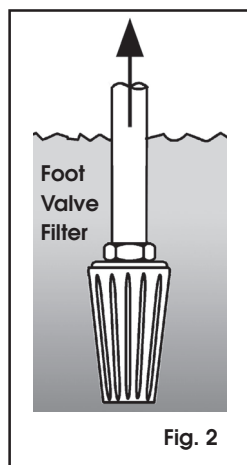

Fig. 2

The performance of your pump will be affected by the diameter of the inlet pipe - any restriction will greatly reduce the flow. We strongly recommend that you use a pipe diameter as large as practical.

A gate valve may be installed in-line on the delivery side (outlet port) of the pump which can be adjusted as required to regulate the flow of water, and can assist in priming the pump.



CAUTION: DO NOT PLACE ANY SUCH OBSTRUCTION ON THE SUCTION (INLET) SIDE OF THE PUMP UNLESS IT IS AN ISOLATOR VALVE IN A GRAVITY FED SYSTEM. THESE PUMPS SHOULD NOT BE OPERATED WITH THE DELIVERY VALVE COMPLETELY CLOSED.

To prevent unnecessary strain or possible distortion to the pump, ensure that adequate support is provided to the hoses and or pipes. They will be considerably heavier when filled with water.

Should contaminants come into contact with the pump, flush through with cold water as soon as possible to prevent damage to the pump.

Protect the pump and pipework from freezing. The formation of ice may cause serious damage.

Where the pump is to be a permanent fixture, the connections to the pump **MUST** be flexible, i.e. a short piece of hose should be inserted between the rigid pipework and the pump.

IMPORTANT: *An air leak in the suction line will inhibit priming and reduce the capacity of the pump.*

Pay particular attention to the following:

- Keep all hoses as short and straight as possible and avoid sharp bends.
- Ensure there is adequate drainage for the discharged water.
- If a flexible hose must be laid across a roadway, protect it with planking.

(Instantaneous shut off pressure, applied when a vehicle runs across an unprotected hose, could cause "hydraulic shock", which can damage the pump and/or the hose).

CONNECTING A FOOT VALVE/FILTER

1. Attach a foot valve/filter to the end of the suction hose to prevent stones etc, from being drawn up, which could cause damage to the pump. Keep the strainer clean. If it is likely to clog with dirt or debris, proceed by either:
 - a. Preparing a bed of stones on which to rest the strainer.
 - b. Tying the strainer so that it stays clear of the bottom of the pit, pond or excavation.
 - c. Tie the strainer inside a basket or bucket.

PRIMING THE PUMP

1. Remove the filler plug on top of the pump case and prime the pump by filling completely with water, leaving no air gap. Remember the pump is self-priming only when filled, after which, it will re-prime itself without refilling. Refilling is necessary only if the pump has been drained, or if all the water has been lost.

- Note: the BPD800 & 1200SS have the ON/OFF switch mounted on the opposite side of the motor.

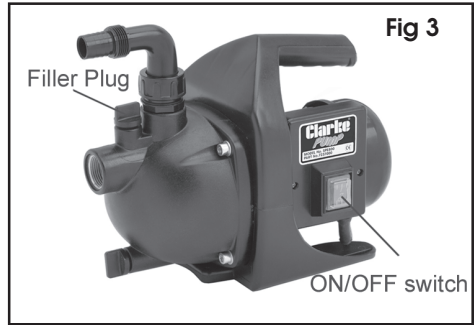

OPERATION

1. Open any valves in the pipeline.
2. Connect the power supply and switch the pump ON.
3. Wait for the pump to prime.
4. If the motor fails to start or the pump does not deliver water refer to TROUBLESHOOTING.

NOTE: Filling the suction pipe with water will speed up the priming process, and it is recommended that a non-return valve be fitted to the end of the suction pipe.

In the event of blockages, where debris has entered the suction chamber, the chamber can be taken off and cleaned out as described under Maintenance on page 10.

5. Periodically, check the level of the water being removed and never allow the pump to run dry.
6. Stop the pump by switching the pump the OFF (O) position.

MAINTENANCE

The only maintenance required is a regular inspection to ensure that leaves and other debris is not blocking the passage of water through the pump.

If you suspect the pump is blocked by mud, silt, leaves etc, disconnect it from the mains supply and backflush to clear any blockage through the drain plug.

Always keep the pump in a clean condition, checking regularly for loose bolts or a damaged power cable etc.

If the pump has been used under arduous conditions leading to internal fouling or damage, the impeller housing can be removed by undoing the four socket-headed impeller housing bolts shown in Fig 4.

The impeller can then be inspected for damage.

- Note that the SPE1200SS pump also includes a 13mm hexagonal connector used to extend the bolts between pump & motor housing (item 25 on p16).

STORAGE

After use, drain the pump body whenever there is danger of freezing. If the pump has been used with contaminated or salty water, it should be thoroughly flushed with clean water following use, both inside and out. It should then be drained before replacing the drain plug and storing in a clean dry environment not exposed to the weather.

In the event that dismantling and overhaul of the pump is necessary, contact your CLARKE International Service Department on 020-8988-7400.

ACCESSORIES

A wide range of accessories is available, including Filters, Foot Valves, Hoses, Couplings and 90° Hose Adaptors, etc. Contact your Clarke dealer for further information or Clarke International Sales Department on 01992 565333.

These pumps are supplied with a 1" male 90° hose adaptor.

The use of parts other than genuine Clarke replacement parts may result in possible safety hazards or decreased machine performance, and will invalidate your warranty.

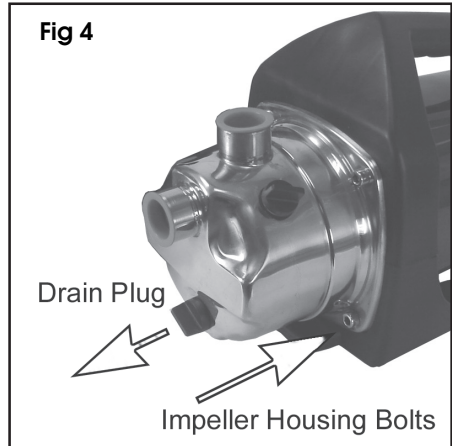

TROUBLESHOOTING

| PROBLEM | CAUSE | SOLUTION |
|----------------------------------|---|---|
| Pump does not run. | No mains supply | Check fused power supply and replace fuse if necessary (check fuse rating) |
| | Impeller seized/blocked. | Disconnect pump from mains supply. Investigate cause and clear blockage. |
| Pump fails to prime. | Priming chamber not filled correctly. | Fill priming chamber leaving no air gap as described on page 9. |
| | Air leaks through suction hose joints (damaged hose, broken clamp, damaged / ill-fitting gasket). | Repair connections/replace hose as necessary. |
| | Blocked inlet hose. | Clean foot valve & ensure it is not submerged in mud/sediment etc. Ensure there are no kinks in inlet hose. |
| Pump runs but gives poor output. | Inlet pipe leakage. | Check inlet pipe and connector for leaks. Tighten as required. |
| | Inlet strainer is blocked. | Check and clean the foot valve. |
| | Impeller / mechanical seal is badly worn. | Return to your CLARKE dealer for repair. |
| | Congested material inside pump. | Dismantle pump housing & clean out. |
| | Impeller damaged and making poor seal. | Return to your CLARKE dealer for repair. |
| | Suction lift too high. | Set pump as close as possible to the level of the liquid to be pumped. |
| | Suction or delivery line obstructed. | Remove obstruction and ensure there are no kinks in delivery line. |
| | High friction losses in the suction line. | Avoid unnecessary curves, restrictions or valves. |
| | Air leaks through damaged seal. | Renew seal. |
| Sudden loss of flow. | Loose or leaking connection to inlet pipe. | Check pipeline and correct. |
| | Suction head is too high and causing cavitation. | Check suction head and lower the position of the pump. |

TROUBLESHOOTING

| PROBLEM | CAUSE | SOLUTION |
|---------------------------|---|--|
| Undue vibration or noise. | Excessive flow of water. | Decrease flow of water. |
| | Resistance in inlet pipe caused by obstruction. | Check pipe and clean out as necessary. |
| | Loose rotating component. | Return to your dealer for repairs. |
| | Installation of pump is not stable. | Stop pump and re-position. |
| | Air pocket in pump or pipeline. | Release drain plug in impeller housing to release air. |
| | Damaged impeller | Return to your CLARKE dealer for repair. |

SPE PUMP PERFORMANCE

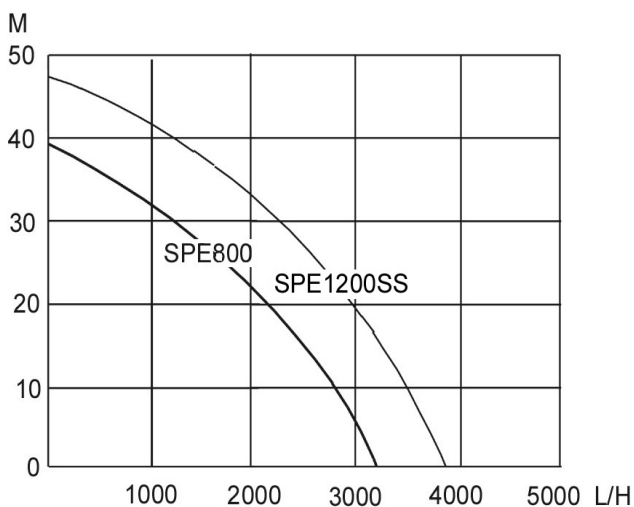

PARTS LIST - SPE800

| No | Description | Part No |
|----|----------------------|------------|
| 1 | Allen Bolt | DHSPE80001 |
| 2 | Washer | DHSPE80002 |
| 3 | Cooling Fan | DHSPE80003 |
| 4 | Motor End Casting | DHSPE80004 |
| 5 | Spring Washer | DHSPE80005 |
| 6 | Motor Tie Bolt 120mm | DHSPE80006 |
| 7 | Motor Stator | DHSPE80007 |
| 8 | Motor Bearing | DHSPE80008 |
| 9 | Motor Rotor | DHSPE80009 |
| 10 | Motor Bearing | DHSPE80010 |
| 11 | Machine Screw | DHSPE80011 |
| 12 | Capacitor | DHSPE80012 |
| 13 | Screw | DHSPE80013 |
| 14 | Cable Clip | DHSPE80014 |
| 15 | Cable Gland | DHSPE80015 |
| 16 | Power Cable & Plug | DHSPE80016 |
| 17 | Grommit | DHSPE80017 |
| 18 | Switch Housing Panel | DHSPE80018 |
| 19 | Cover Panel | DHSPE80019 |
| 20 | Switch Seal | DHSPE80020 |

| No | Description | Part No |
|----|--------------------|------------|
| 21 | Rocker Switch | DHSPE80021 |
| 22 | Self-tapping Screw | DHSPE80022 |
| 23 | Handle Moulding | DHSPE80023 |
| 24 | Handle End Cap | DHSPE80024 |
| 25 | Locknut | DHSPE80025 |
| 26 | Base Moulding | DHSPE80026 |
| 27 | Connecting Screw | DHSPE80027 |
| 28 | Frame Casting | DHSPE80028 |
| 29 | Mechanical Seal | DHSPE80029 |
| 30 | O-Ring 140 dia | DHSPE80030 |
| 31 | Impeller | DHSPE80031 |
| 32 | Fixed Ring | DHSPE80032 |
| 33 | End Fixing | DHSPE80033 |
| 34 | Diffuser Plate | DHSPE80034 |
| 35 | Diffuser | DHSPE80035 |
| 36 | Discharge Elbow | DHSPE80036 |
| 37 | O-Ring 30 dia | DHSPE80037 |
| 38 | Plastic Housing | DHSPE80038 |
| 39 | Threaded Plug 15mm | DHSPE80039 |
| 40 | O-Ring 18 dia | DHSPE80040 |

IMPORTANT: The use of parts other than genuine CLARKE replacement parts may result in safety hazards, decreased performance, and will invalidate your warranty.

PARTS DIAGRAM - SPE800

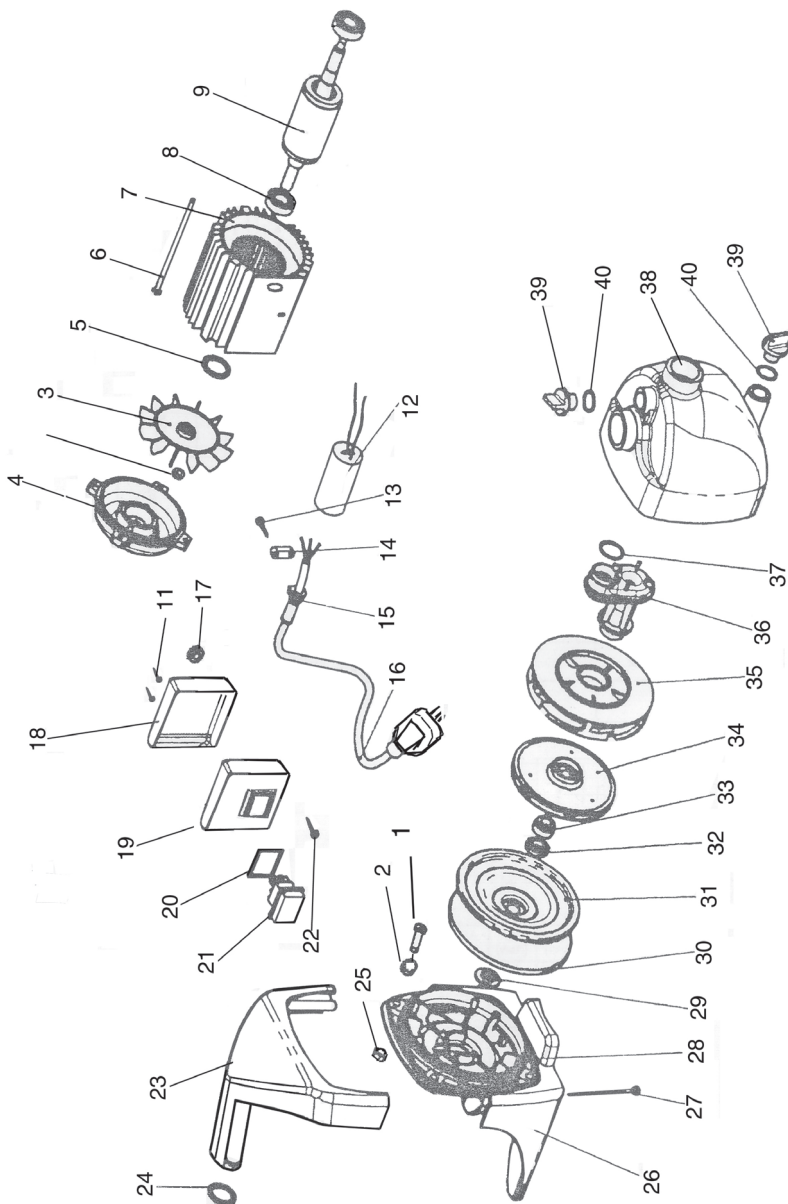

PARTS LIST - SPE1200SS

| No | Description | Part No |
|----|----------------------|--------------|
| 1 | Allen Bolt 12mm | DHSPE120001 |
| 2 | Motor Cover | DHSPE120002 |
| 3 | Cooling Fan | DHSPE120003 |
| 4 | Motor End Casting | DHSPE120004 |
| 5 | Spring Washer | DHSPE120005 |
| 6 | Motor Tie Bolt 150mm | DHSPE120006 |
| 7 | Motor Stator | DHSPE120007 |
| 8 | Motor Bearing | DHSPE120008 |
| 9 | Motor Rotor | DHSPE120009 |
| 10 | Motor Bearing | DHSPE120010 |
| 11 | S/T Screw 15mm | DHSPE120011 |
| 12 | Capacitor | DHSPE120012 |
| 13 | S/T Screw 19mm | DHSPE120013 |
| 14 | Cable Clamp | DHSPE120014 |
| 15 | Cable Gland | DHSPE120015 |
| 16 | Power Cable & Plug | DHSPE1200016 |
| 17 | Rubber Grommit | DHSPE120017 |
| 18 | Transparant Cover | DHSPE120018 |
| 19 | Cover Panel | DHSPE120019 |
| 20 | Switch Seal | DHSPE120020 |
| 21 | Switch | DHSPE120021 |

| No | Description | Part No |
|----|--------------------|-------------|
| 22 | Screw | DHSPE120022 |
| 23 | Handle Moulding | DHSPE120023 |
| 24 | Handle End Cap | DHSPE120024 |
| 25 | Hex Connector 13mm | DHSPE120025 |
| 26 | Base Moulding | DHSPE120026 |
| 27 | Connecting Screw | DHSPE120027 |
| 28 | Frame Casting | DHSPE120028 |
| 29 | Mechanical Seal | DHSPE120029 |
| 30 | O-Ring 140 dia | DHSPE120030 |
| 31 | Impeller | DHSPE120031 |
| 32 | Fixing Ring | DHSPE120032 |
| 33 | End Fixing | DHSPE120033 |
| 34 | Diffuser Plate | DHSPE120034 |
| 35 | Diffuser | DHSPE120035 |
| 36 | Discharge Elbow | DHSPE120036 |
| 37 | O-Ring 30 dia | DHSPE120037 |
| 38 | Stainless Housing | DHSPE120038 |
| 39 | Threaded Plug 12mm | DHSPE120039 |
| 40 | O-Ring 16 dia | DHSPE120040 |
| 41 | Allen Bolt x 19mm | DHSPE120041 |
| | | |

PARTS DIAGRAM - SPE1200SS

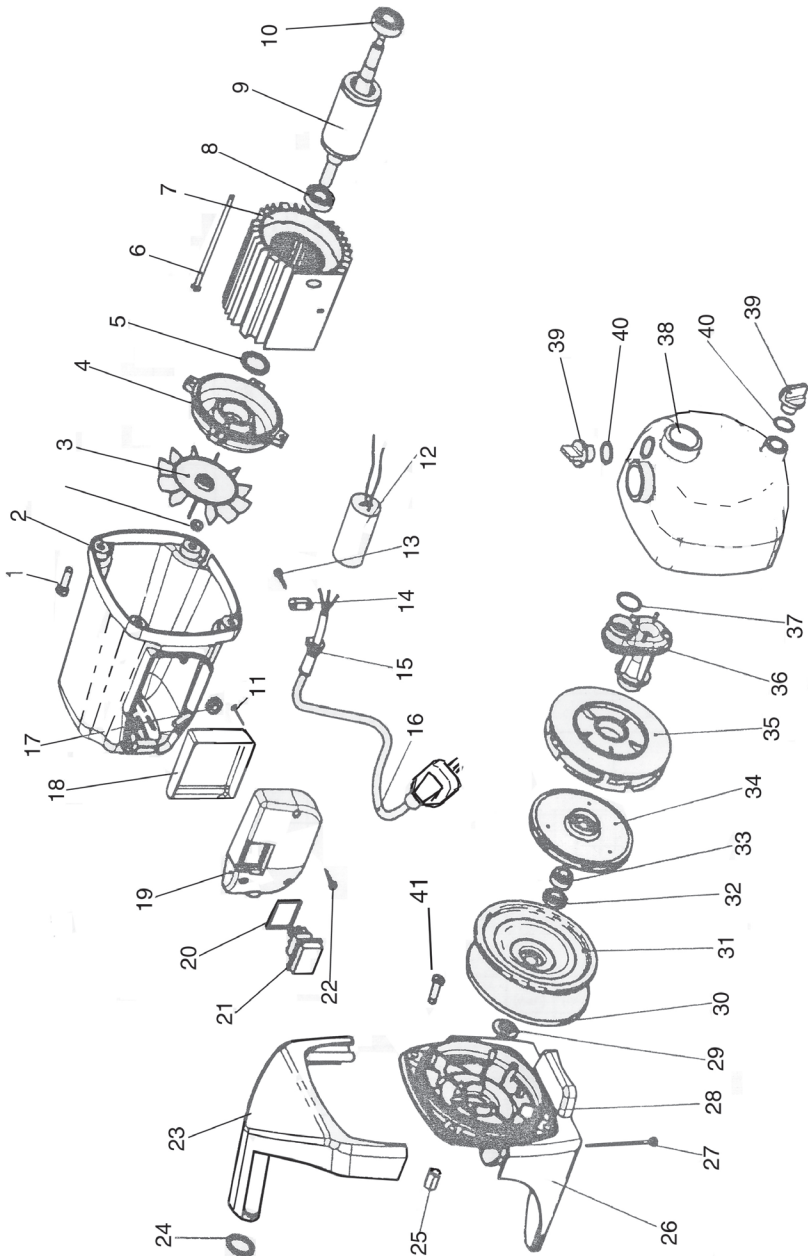

TECHNICAL SPECIFICATION

| | SPE800 | SPE1200 |
|---------------------------|------------------------|------------------------|
| Weight | 6.7 kg | 8.2 kg |
| Dimensions (L x W x H) mm | 330 x 210 x 245 | 348 x 218 x 243 |
| Max Flow | 53 L/min | 61 L/min |
| Max Head | 40 m | 46 m |
| Max Depth | 8 m | 8 m |
| Operating Temperature | 35°C | 35°C |
| Water Classification | Clean Water | Clean Water |
| Inlet Size | 1" BSP | 1" BSP |
| Outlet Size | 1" BSP | 1" BSP |
| Power Supply | 230V @ 50Hz | 230V @ 50Hz |
| Input Current | 800W | 1200W |
| Sound Pressure Level | 73 dB LpA | 73 dB LpA |
| Sound Power Level | 84 dB LwA | 84 dB LwA |
| Guaranteed Sound Power | 86 dB LwA | 86 dB LwA |
| Self Priming | Yes (using foot valve) | Yes (using foot valve) |
| Pump type | Centrifugal | Centrifugal |

Please note that the details and specifications contained herein, are correct at the time of going to print. However, CLARKE International reserve the right to change specifications at any time without prior notice.

DECLARATION OF CONFORMITY



Clarke[®]
INTERNATIONAL

Hemncall Street, Epping, Essex CM16 4LG

DECLARATION OF CONFORMITY

This is an important document and should be retained.

Product Description: 800W Garden Pump
Model number(s): SPE800
Serial / batch Number: 7237000
Date of Issue: 29/10/2010
(Noise Conformity)
Notified Body: TUV Rheinland LGA Products GmbH
90431 Nürnberg
Tillystraße
Germany

Technical Documentation Holder: A.R. Pond
Clarke International
2a Shrubland Road
London E10 7RB
UK

Conformity Assessment Procedure: to 2000/14/EC Annex V
Manufacturer: Clarke International
Noise Related Value: 0.8kW
Measured Sound Power Level: 79.19dB
Guaranteed Sound Power Level: 80.0dB

DECLARATION OF CONFORMITY



Clarke[®]
INTERNATIONAL

Hemncill Street, Epping, Essex CM16 4LG

DECLARATION OF CONFORMITY

This is an important document and should be retained.

We hereby declare that this product(s) complies with the following directive(s):

- 2004/108/EC Electromagnetic Compatibility Directive.*
- 2006/95/EC Low Voltage Equipment Directive.*
- 2002/95/EC Restriction of Hazardous substances.*
- 2000/14/EC Noise Emissions Directive (amended by 2005/88/EC).*

The following standards have been applied to the product(s):

- EN 55014-1:2006, EN 55014-2:1997+A1, EN 61000-3-2:2006, EN 61000-3-3:1995+A1+A2*
- EN 60335-1:2002+A1+A11+A12+A2+A13, EN 60335-1-41:2003+A1, EN 50366:2003+A1.*

The technical documentation required to demonstrate that the product(s) meet(s) the requirement(s) of the aforementioned directive(s) has been compiled and is available for inspection by the relevant enforcement authorities.

The CE mark was first applied in: 2006

Signed:

J.A. Clarke
Director

DECLARATION OF CONFORMITY



Clarke[®]
INTERNATIONAL

Hemnal Street, Epping, Essex CM16 4LG

DECLARATION OF CONFORMITY

This is an important document and should be retained.

Product Description: 1200W Garden Pump with stainless steel housing

Model number(s): SPE1200SS

Serial / batch Number: 7237002

Date of Issue: 29/10/2010

(Noise Conformity)

Notified Body: TUV Rheinland LGA Products GmbH
90431 Nürnberg
Tillystraße
Germany

Technical Documentation Holder: A.R. Pond
Clarke International
2a Shrubland Road
London E10,7RB
UK

Conformity Assessment Procedure: to 2000/14/EC Annex VI

Manufacturer: Clarke International

Noise Related Value: 1.2kW

Measured Sound Power Level: 84.0dB

Guaranteed Sound Power Level: 86.0dB

DECLARATION OF CONFORMITY



Clarke[®]
INTERNATIONAL

Hemnall Street, Epping, Essex CM16 4LG

DECLARATION OF CONFORMITY

This is an important document and should be retained.

We hereby declare that this product(s) complies with the following directive(s):

2004/108/EC *Electromagnetic Compatibility Directive.*

2006/95/EC *Low Voltage Equipment Directive.*

2002/95/EC *Restriction of Hazardous substances.*

2000/14/EC *Noise Emissions Directive (amended by 2005/88/EC).*

The following standards have been applied to the product(s):

EN 55014-1:2006, EN 55014-2:1997+A1, EN 61000-3-2:2006, EN 61000-3-3:1995+A1+A2

EN 60335-1:2002+A1+A11+A12+A2+A13, EN 60335-1-41:2003+A1, EN 50366:2003+A1.

The technical documentation required to demonstrate that the product(s) meet(s) the requirement(s) of the aforementioned directive(s) has been compiled and is available for inspection by the relevant enforcement authorities.

The CE mark was first applied in: 2009

Signed:

J.A. Clarke
Director

A SELECTION FROM THE VAST RANGE OF

Clarke®

QUALITY PRODUCTS

AIR COMPRESSORS

From DIY to industrial, Plus air tools, spray guns and accessories.

GENERATORS

Prime duty or emergency standby for business, home and leisure.

POWER WASHERS

Hot and cold, electric and engine driven - we have what you need

WELDERS

Mig, Arc, Tig and Spot. From DIY to auto/industrial.

METALWORKING

Drills, grinders and saws for DIY and professional use.

WOODWORKING

Saws, sanders, lathes, mortisers and dust extraction.

HYDRAULICS

Cranes, body repair kits, transmission jacks for all types of workshop use.

WATER PUMPS

Submersible, electric and engine driven for DIY, agriculture and industry.

POWER TOOLS

Angle grinders, cordless drill sets, saws and sanders.

STARTERS/CHARGERS

All sizes for car and commercial use.



PARTS & SERVICE: 0208 988 7400

E-mail: Parts@clarkeinternational.com or Service@clarkeinternational.com

SALES: UK 01992 565333 or Export 00 44 (0)1992 565335

Clarke INTERNATIONAL Hemnall Street, Epping, Essex CM16 4LG
www.clarkeinternational.com