

Light Drainage Pump Type ABS Robusta 200 C

Plug-in submersible pump, for the removal of lightly aggressive water/wastewater containing solids up to 10 mm.

Applications

The Robusta 200 C has been designed for fixed or transportable installation, and for internal or external applications such as pumping condensate water out of heating systems, brine from softening systems, or aggressive rainwater.

Construction

- Single-phase, 50 Hz, 2-pole motor; insulation class B; protection type IP68. Motor is dynamically balanced with stainless steel shaft. Thermal sensors in the stator switch off the pump in the case of overheating and automatically switch it back on after cooling down.
- The stainless steel rotor shaft is supported in lubricated-for-life ball bearings.
- Connection chamber with cover and watertight cable inlet and strain relief.
- Discharge outlet with internal thread, built-in checkvalve, and detachable multi-stage hose adaptor.
- Sealing on the motor shaft by a high-quality mechanical seal.
- The medium being pumped flows around the motor housing for optimum heat dissipation. The maximum allowable medium temperature is 40 °C; or up to 60 °C for intermittent usage (max. 5 minutes).
- Built-in automatic level control, with easily removable float cover for cleaning purposes.
- Integrated switch for manual operation in transportable applications.
- Bayonet clamping allows the screen to be removed by hand in the event an impeller inspection is necessary.

Materials

Description	Material
Pump casing	PP
Motor shaft	Stainless steel 1.4401 (AISI 316)
Motor housing	Stainless steel 1.4401 (AISI 316)
Mechanical seal	Viton
Impeller	PA
Seals	Viton
Cable	Neoprene)

The resistance of the materials must be checked by the operator.



Features

- Robusta is fitted with an automatic level control. For transportable applications, the Hand-Auto switch can be set to manual operation.
- The check valve built into the discharge outlet blocks return-flow from the discharge line when the pump is switched off.
- Checkvalve, hose adaptor and 10 m cable with Schuko plug included as standard.
- Suitable for small sumps (from 300 x 300 mm).
- Detachable suction ring. When fitted into the impeller screen allows pumping down to 3 mm (manual operation only).

Installation

Attention to the backwash level is of vital importance for effective dewatering. All outflow points located below the backwash level must be protected against back flow according to EN 12056 standard.

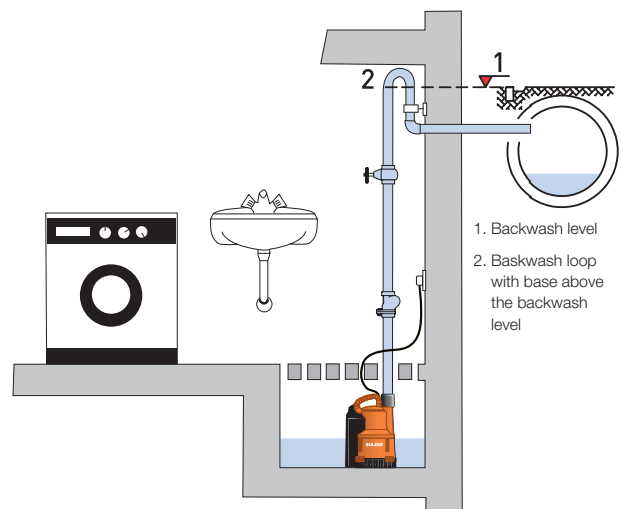

Technical data

Robusta 200 C

Part number	01135059
Discharge connection internal thread	G 1½"
Solids size (mm)	10
Motor power (kW) *	P ₁ = 0.36
Rated voltage (V)	220-240 1~
Rated current (A)	1.6
Speed (r/min)	2900
Cable type (H07RN8-F)	3G1.0
Cable length (m) **	10
Weight (kg)	1.6
Auto-switching levels (mm)	On: 145 Off: 50

* P₁ = Power taken from mains.

** For external applications the following VDE regulation applies: submersible pumps for use externally must have a fixed cable connection with a length of at least 10 m. Regulations vary by country.

Dimensions (mm)

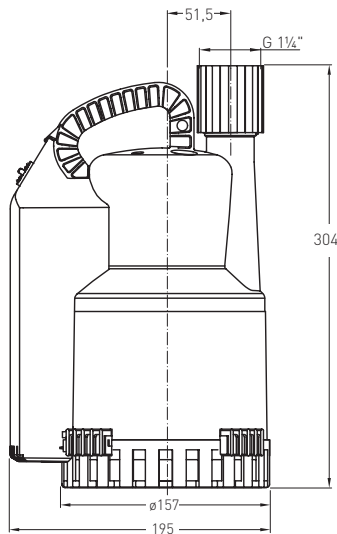

Hose adaptor

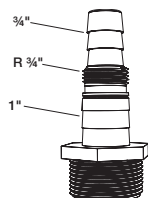

Performance curve

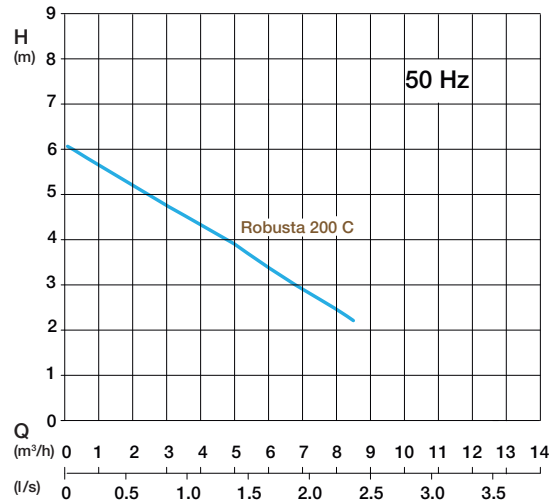

H = Total Head Q = Discharge Volume. Curves to ISO 9906.

Accessories

Description	Part no.
Gate valve (brass) with internal thread G 1½"	14040005
Non-return valve (synthetic) G 1½" flap valve with internal thread	61405030
NC batteries 9VTR 7-8 for mains independent operation	12820018
Plug-in alarm kits: Acoustic alarm with signalling unit for connection to 230 V Schuko socket. Acoustic alarm signal, potential-free NO (Normally Opened) contact (I max 12 A / V max 250 V). Optional rechargeable accumulators for mains-independent alarm signal.	
With KS float switch	16025001
With NSM05 "broken finger"	16025003
With humidistat	16025004
WM-Stop alarm kits: Acoustic alarm with signalling unit for plugging in to a 230 V Schuko socket, with integral 230 V Schuko socket into which the washing machine is plugged (I max 16 A). Optional rechargeable accumulators for mains-independent alarm signal.	
With KS float switch	16025002
With NSM05 "broken finger"	16025005
With humidistat	16025006
Control unit: for double pumping station. Automatic changing of the start sequence, alarm, and potential-free fault indicator.	Contact Sulzer

sulzer.com

Robusta 200 C 50 Hz en 01.2024, Copyright © Sulzer Ltd 2024

This data sheet is a general product presentation. It does not provide a warranty or guarantee of any kind. Please contact us for a description of the warranties and guarantees offered with our products. Directions for use and safety will be given separately. All information herein is subject to change without notice.