



Pump data

Make	Lowara
Port to port (mm)	250
Electrical connection	Terminals
Specific EEI	<= 0,23
Nominal pressure	PN 6/10
Connection	Flanged / DN 40

Electrical data

Rated voltage	230 V
Frequency	50 / 60
Protection class	IP 44
Insulation class	F
Digital input	Contact load: 5V, 10 mA
Digital output	Vmax < 250 VAC / Imax < 2 A
Analog input	0-10 V / 4-20 mA
Leakage current	< 3.5 mA
Communication capabilities	Modbus RTU & BACnet MS/TP
Sound pressure level	<= 52 dB(A)
Rated current	2.9 A

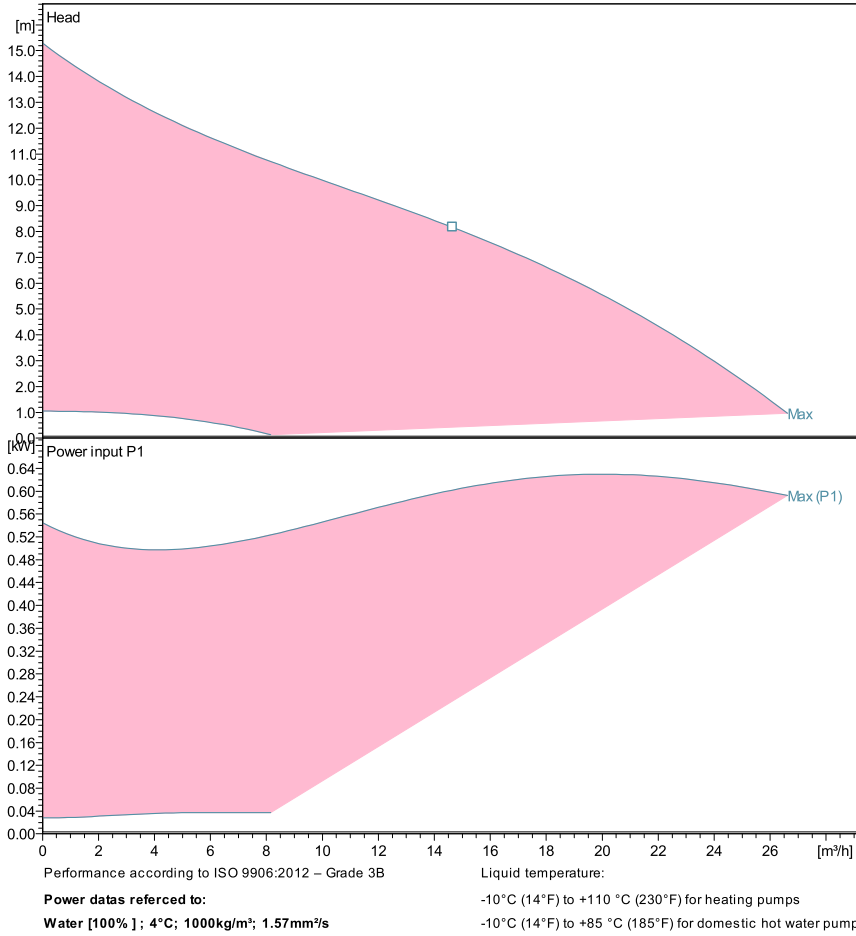

Materials

Bush Bearing	Carbon, resin impregnated	IMPELLER	PPS
Thrust bearing	Aluminum oxide	WEAR RING	Stainless steel
Bearing plate	Stainless steel	Rotor can	Stainless steel
Motor housing	Aluminum	SHAFT	Stainless steel
O-rings	EPDM	Control box	Poly carbonate
PUMP HOUSING	Cast Iron		

Dimensions mm

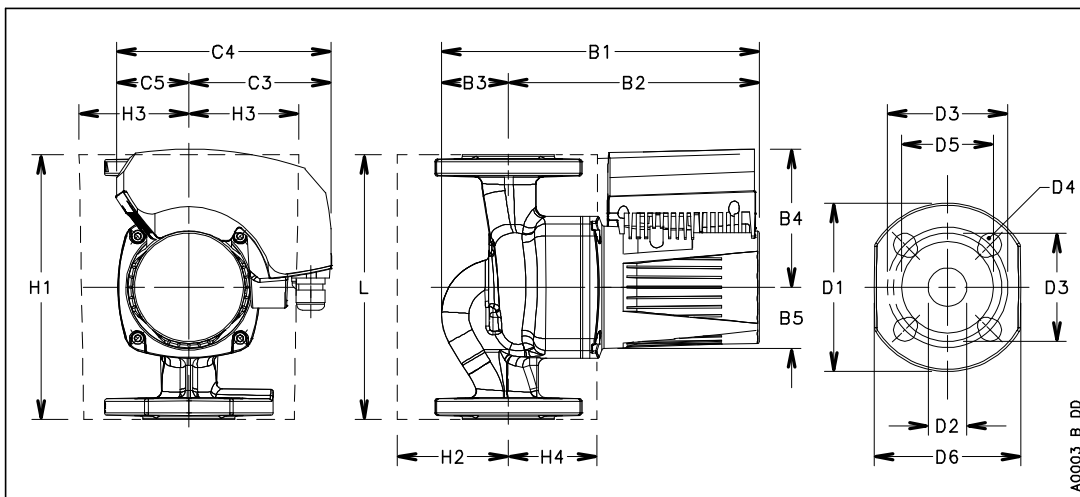

B1	365
B2	299
B3	66
B4	147
B5	61
C3	146
C4	239
C5	93
D1	150
D2	40
D3	100/110
D4	4 x 14/19
D5	84
G	DN 40
Gross Weight	21.6
H1	240
H2	86
H3	90/102
H4	93
L	250
Net Weight	17.8