



Pump data

Make	Lowara
Port to port (mm)	360
Electrical connection	Terminals
Specific EEI	<= 0,23
Nominal pressure	PN 6
Connection	Flanged / DN 80

Electrical data

Rated voltage	230 V
Frequency	50 / 60
Protection class	IP 44
Insulation class	F
Digital input	Contact load: 5V, 10 mA
Digital output	Vmax < 250 VAC / Imax < 2 A
Analog input	0-10 V / 4-20 mA
Leakage current	< 3.5 mA
Communication capabilities	Modbus RTU & BACnet MS/TP
Sound pressure level	<= 55 dB(A)
Rated current	6.6 A

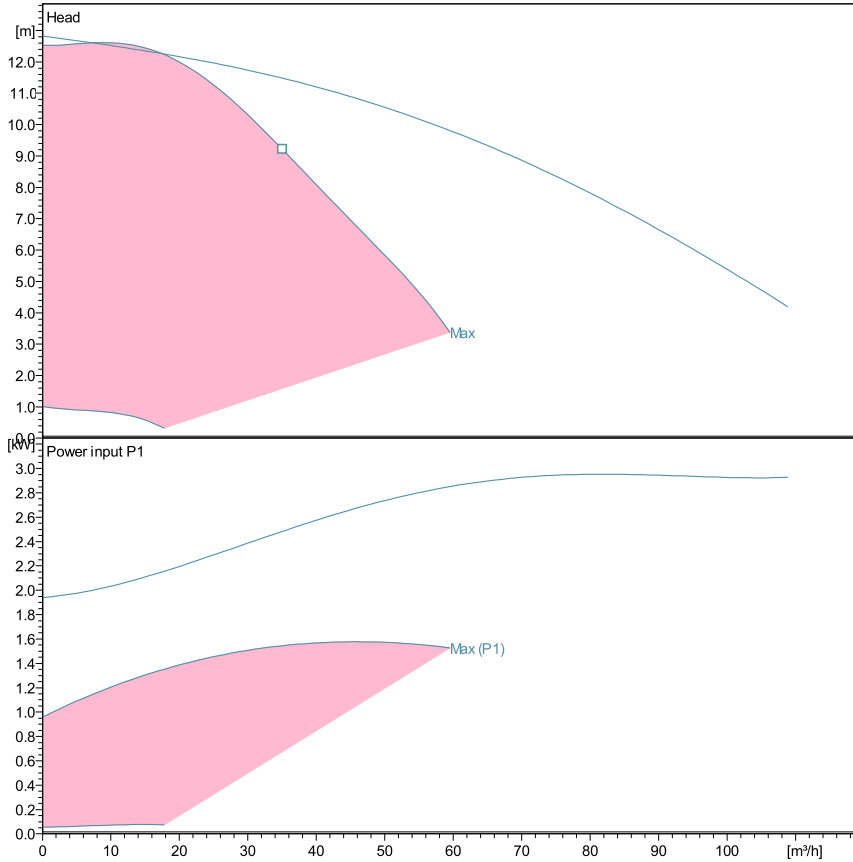

Performance according to ISO 9906:2012 – Grade 3B

Liquid temperature:

-10°C (14°F) to +110 °C (230°F) for heating pumps

-10°C (14°F) to +85 °C (185°F) for domestic hot water pumps

Power datas referred to:

Water [100%]; 4°C; 1000kg/m³; 1.57mm²/s

Materials

Bush Bearing	Carbon, resin impregnated	IMPELLER	PPS
Thrust bearing	Aluminum oxide	WEAR RING	Stainless steel
Bearing plate	Stainless steel	Rotor can	Stainless steel
Motor housing	Aluminum	SHAFT	Stainless steel
O-rings	EPDM	Control box	Poly carbonate
PUMP HOUSING	Cast Iron		

Dimensions mm

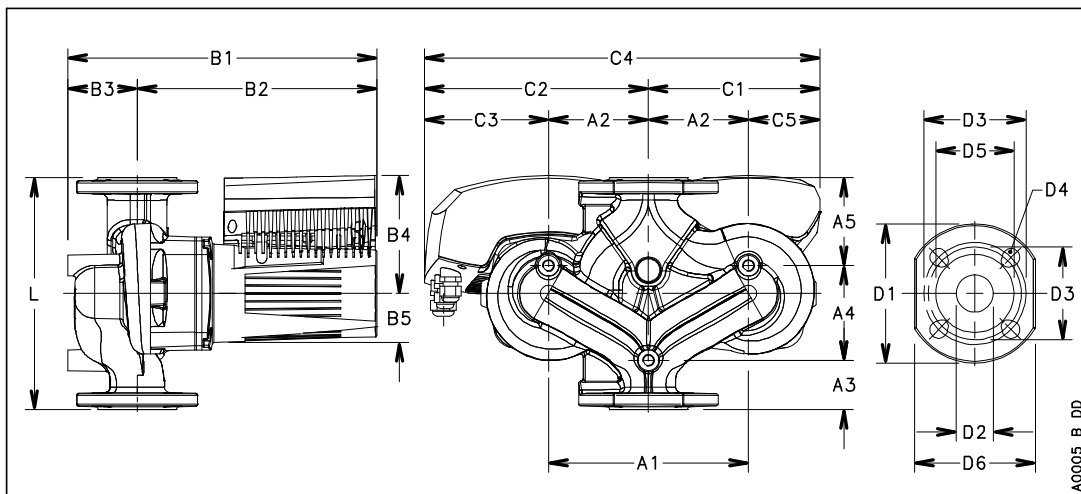

A1	240
A2	120
A3	70
A4	145
A5	145
B1	396
B2	306
B3	90
B4	147
B5	60
C1	213
C2	268
C3	148
C4	481
C5	93
D1	200
D2	80
D3	150
D4	4 x 19
D5	132
G	DN 80
Gross Weight	61.8