



PumpPal is a compact versatile control unit, primarily used for operation of a 1ph pump up to 8A FLC, via level control.

Suitable for dual input voltages 230v & 110v 1ph, PumpPal incorporates mains healthy & pump running indication, and can be used for filling and emptying applications, with level control by either our LevelPal unit, float switch or conductivity probes.

Particularly suited to dewatering critical locations where water should not be present, an audible warning alarm is provided which can be sounded or silenced during pump operation.



Level Pal

FEATURES

- Motor control up to 8A FLC
- Dual input voltage 230v or 110v 1ph
- Mains on indicator
- Pump run indicator
- Audible alarm c/w mute (selectable)
- Filling or emptying applications
- Suitable for float, conductivity probe or LevelPal use
- Run on timer for use with residue pumps
- Test button facility
- Sensitivity selector for probes

SPECIFICATIONS

- Supply voltage - 230V + 10% - 20% 50Hz 6VA (optional 110V)
- Output relay - 8A inductive
- Internal fuse - 20 x 5mm, 250mA Anti Surge
- Run on timer range - 2 to 60 seconds
- Sensitivity range - 10K Ω to 100K Ω
- Terminal capacity - 2.5mm² Max
- Ambient temp - -10°C to 50°C
- Weather-proof IP66
- Enclosure dimensions - 130mm H x 145mm W x 60mm D
[113mm x 113mm centers, M4]

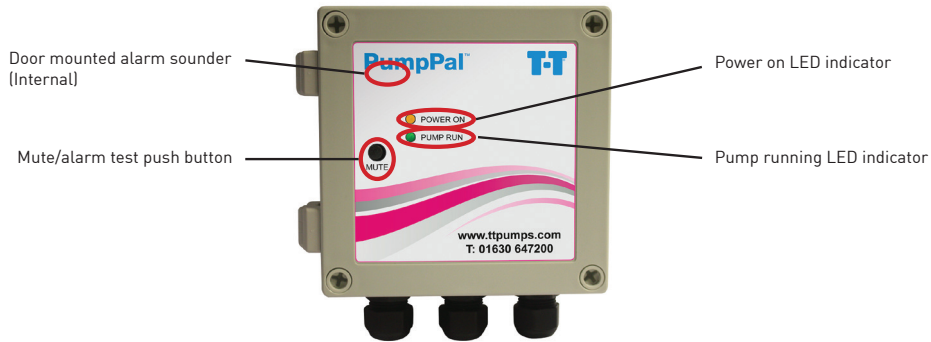

Key
 BE = Blue Core
 BN = Brown Core
 GY = Green/Yellow Core

Using LevelPal

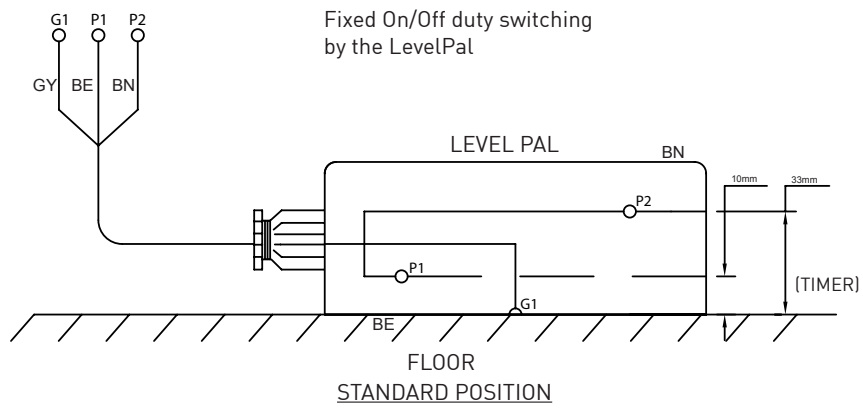

Alternate position with a greater differential suitable for On/Off switching by the LevelPal

