

techflo tp

Standard Twin Pumps

Standard Twin pumps are designed to boost the incoming hot and cold water supply to an individual [shower](#), bath, [shower mixer](#) or mixer tap. Suitable for positive head applications only.

Techflo tp pumps require a flow of 0.8 l/min through the outlet to start.



Features

- Durable plastic construction
- 1.5 and 2.0 bar performance options
- Automatic switching
- Nitrile/carbon/silicon carbide seal
- 15 mm push-in flexible hoses
- G 3/4 threaded connections
- Pre-wired with 1.5 metre power cable
- Anti-vibration feet
- 1-year guarantee (subject to conditions)
- WRAS approved

Application

- Boost hot and cold water supplies equally
- Single function [shower](#)
- Bath/basin mixer tap

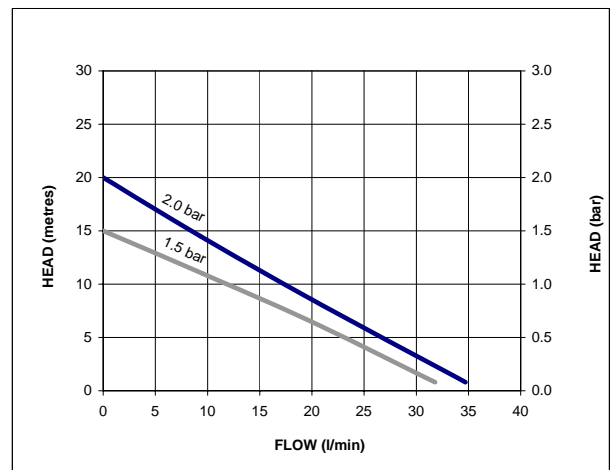

techflo tp

Pump Model		S1.5 bar Twin 49084	S2.0 bar Twin 49085
General	Guarantee	1 year	
	WRAS approved	1506334	
Features	Pump type	Centrifugal	
	Mechanical seal	Nitrile / Carbon / Silicon Carbide	
	Anti-vibration feet	✓	✓
	Inlet strainer(s)	✓	✓
	Flexible hoses	4	4
	Dry run protection	✓	✓
Materials	Pump body	Plastic	
	Impeller	Plastic	
Performance	Maximum head (closed valve)	1.5 bar	2.0 bar
	Performance @ 9 l/min	1.1 bar	1.5 bar
	Performance @ 18 l/min	0.7 bar	0.9 bar
	Maximum flow	32 l/min	35 l/min
	Maximum static inlet pressure	10 metres	
	Maximum working pressure*	300 kPa (3 bar)	
	Maximum ambient air temperature	40 °C	
	Min / Max water temperature**	Min 4 °C / Max 65 °C	
	Flow switch sensitivity (approx)	0.8 l/min	
Connections	Pump connections	G 3/4 male	
Flexible hoses	Connections	G 3/4 female x 15 mm push-in x 185 mm long (inlet) G 3/4 female x 15 mm push-in x 175 mm long (outlet)	
Motor	Type	Series wound, manual reset thermal trip	
	Duty rating	Intermittent (S3) 30 mins on/30 mins off @ 9 l/min***	
Electrical	Power supply / phase / frequency	230 V a.c. / 1 / 50 Hz	
	Current (full load)	1.2 Amps	1.5 Amps
	Power consumption	200 Watts	300 Watts
	Fuse rating	3 Amps	
	Power cable (pre-wired)	1.5 metres	
Physical	Enclosure protection	IPX2	
	Length	250 mm	
	Width	97 mm	
	Height (excluding hoses)	152 mm	
	Weight (including fittings)	2.6 Kg	

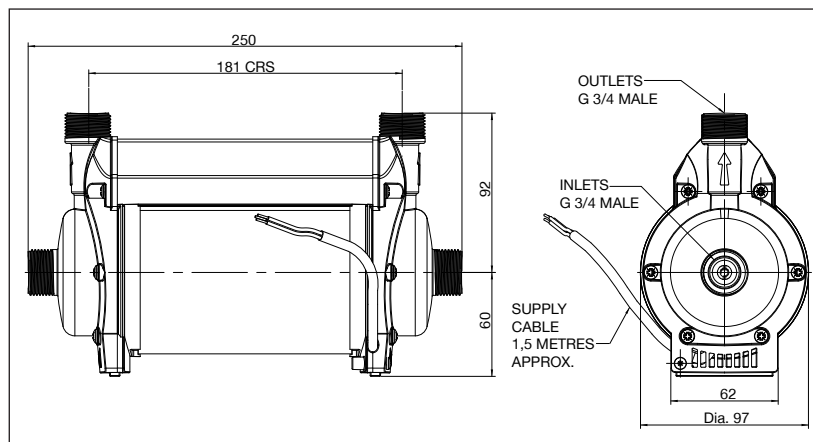

* The maximum pressure that can be applied to the pump under any installation conditions.

** A stored water temperature of 60 °C is considered sufficient to meet all normal requirements and will minimise deposition of scale in hard water areas.

*** Both heads pumping 4.5 l/min.

Stuart Turner Limited reserves the right to amend specifications without notice.